



Harsco Track Technologies

Harsco

www.harscotrack.com

SERVICE BULLETIN MAINTENANCE OF WAY EQUIPMENT

DATE: 7-10-2003 **BULLETIN NO:** 03-006

TITLE: 4001084 DUST COLLECTOR FLEX-DUCT KIT

RATING:

<input type="checkbox"/>	DIRECTIVE (Action Is Required)	<input type="checkbox"/>	ALERT (Potential Problem)
<input type="checkbox"/>	INFORMATION (Action Is Optional)	<input checked="" type="checkbox"/>	PRODUCT IMPROVEMENT (Enhance Product)

PRODUCT SERIES / MODEL: W139 Series A1 Spike Reclaimer
Holley Spike Reclaimer

SERIAL NO: All W139 Models A1 with Dust Collector Systems
All Holley Models with Dust Collector Systems

SUMMARY: Some Spike Reclaimers in the field are equipped with dust collector systems. On the dust collector system there is a flexible duct tube between the dust collector unit and the out-feed conveyor of the spike tumbler. There have been complaints regarding the premature failure of this flexible duct tube.

OPERATIONAL IMPACT: A kit has been designed to replace the existing flexible duct tube with a new more rugged flexible duct tube to help extend the service life of the tube.

ACTION: The installation of this kit involves removing the existing flexible duct tube and clamps, and installing the new more rugged flexible duct tube and clamps. Order one part # 4001084 Dust Collector Flex-Duct Kit per machine.

CONTACT: If you have any questions or if we can be of any service, please contact the Service Department at the Columbia, SC. facility, (803) 822-9160.

SAFETY INFORMATION



- **FOLLOW APPLICABLE RAILROAD LOCKOUT - TAGOUT PROCEDURE TO REMOVE ALL ENERGY SOURCES FROM MACHINE. FAILURE TO COMPLY COULD RESULT IN SEVERE BODILY INJURY.**

DISASSEMBLY - See Figure 1 or Figure 2

1. Locate the existing duct tube (1) between the dust collector unit and the out-feed conveyor of the spike tumbler on the machine.
2. Remove the two existing clamps (2) and the existing duct tube (1). Discard all items; they will not be re-used.

ASSEMBLY - See Figure 1 or Figure 2

3. Install the new duct tube (1) and two new clamps (2) between the dust collector unit and the out-feed conveyor of the spike tumbler. Tighten the two clamps (2) securely.

03-218

FIGURE 1
DUST COLLECTOR FLEXIBLE DUCT TUBE AND CLAMPS

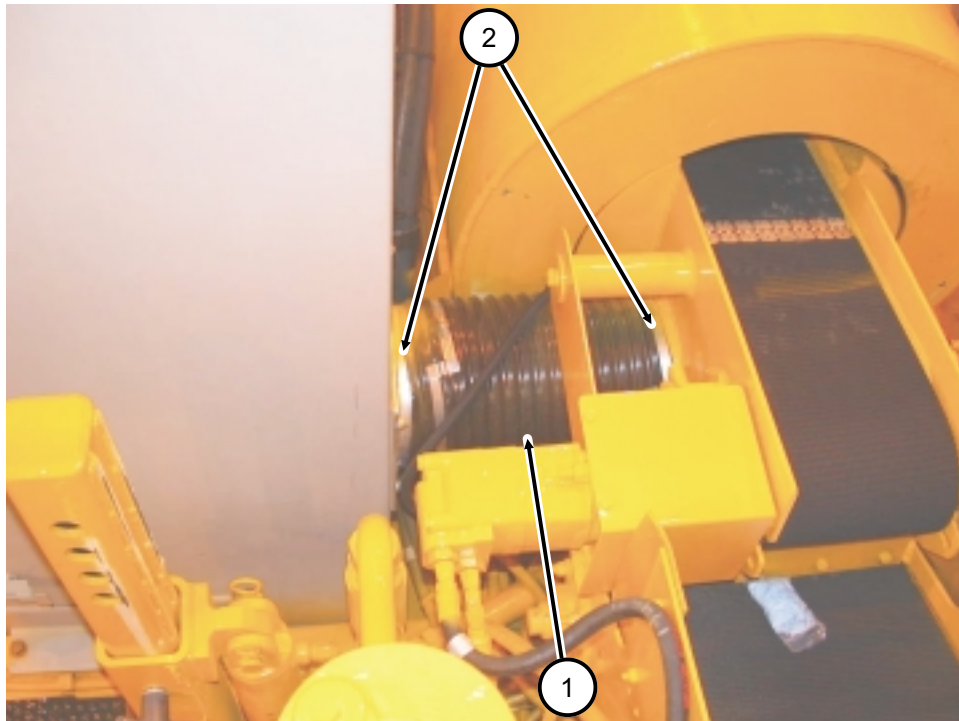

PARTS LIST - See Figure 1 or Figure 2

Note: The quantities listed are for one machine.

ITEM	PART NO	DESCRIPTION	QTY
	4001084	DUST COLLECTOR FLEX-DUCT KIT	1
1	4000734	Poly Flex Tubing - 12-3/4" Long	1
2	4000745	Clamp	2

191058-2

FIGURE 2
DUST COLLECTOR FLEXIBLE DUCT TUBE AND CLAMPS

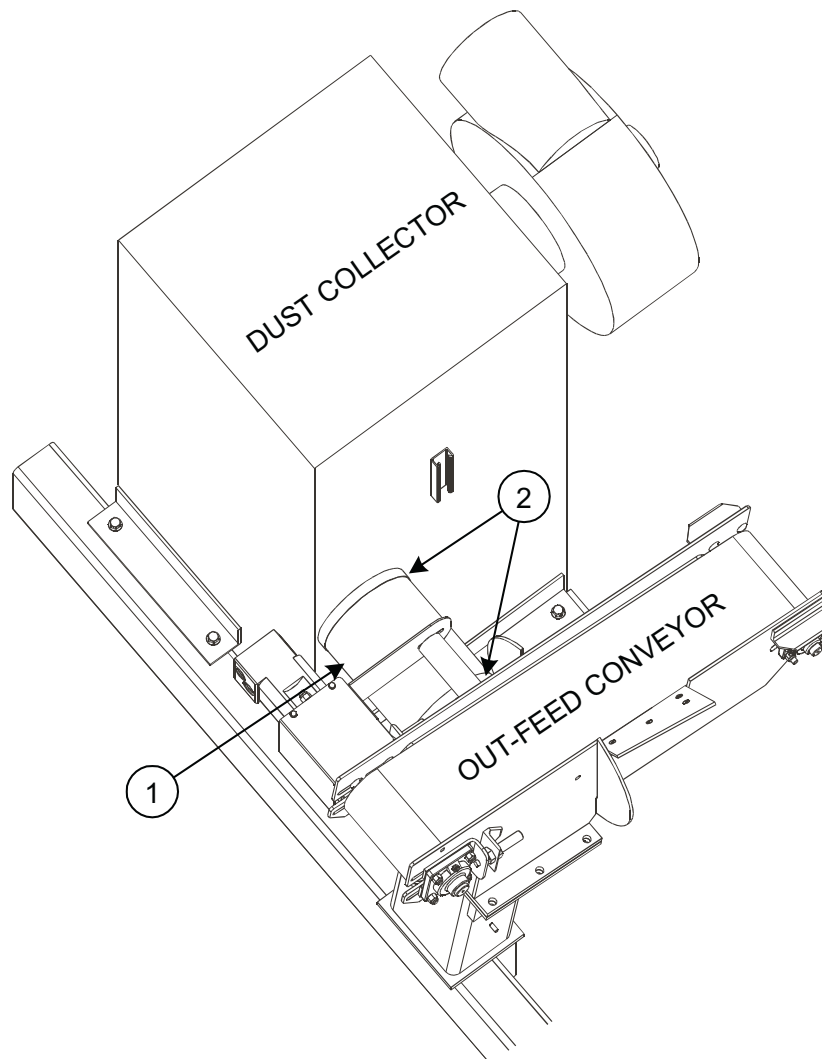

© 2003 HARSCO TRACK TECHNOLOGIES, HARSCO CORPORATION

415 North Main Street
Fairmont, MN
56031-1837
Tel: (507) 235-3361
Fax: (507) 235-7370

2401 Edmund Road, Box 20
Cayce-West Columbia, SC
29171-0020
Tel: (803) 822-9160
Fax: (803) 822-7471

200 South Jackson Road
Ludington, MI
49431
Tel: (231) 843-3431
Fax: (231) 843-4830