

HTT

Harsco Track Technologies

Harsco

HR4000 SERIES V FRONT UNIVERSAL HY-RAIL® GUIDE WHEEL UNIT HYDRAULICALLY OPERATED

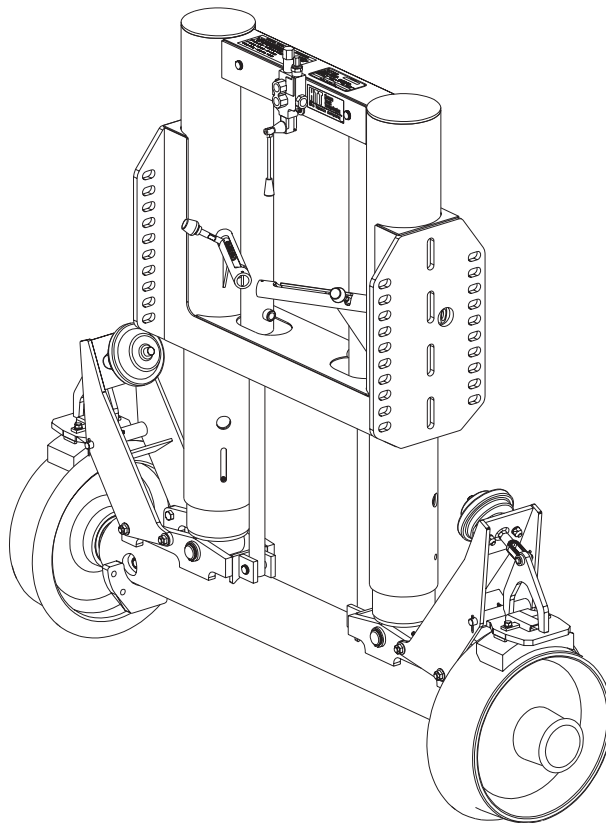

SE02A157A-1

OPERATOR'S SERVICE AND PARTS MANUAL

ISSUED 7 - 2002

BULLETIN 1231A

© 2002 HARSCO TRACK TECHNOLOGIES, HARSCO CORPORATION



■ **THIS MANUAL CONTAINS VITAL INFORMATION FOR THE SAFE USE AND EFFICIENT OPERATION OF THE VEHICLE EQUIPPED WITH HY-RAIL® GUIDE WHEEL EQUIPMENT. CAREFULLY READ THIS OPERATOR'S MANUAL BEFORE USING THE VEHICLE. FAILURE TO ADHERE TO THE INSTRUCTIONS COULD RESULT IN BODILY INJURY AND/OR PROPERTY DAMAGE.**

FAIRMONT™ is a brand name and trademark of products manufactured by Harsco Track Technologies, Harsco Corporation.

HY-RAIL® is a registered trademark of Harsco Track Technologies, Harsco Corporation.

When this manual is received, record the rail pilot unit serial numbers in the spaces provided in the General Information and Parts Sections for future reference, in case the serial number tags ever become unreadable. A Manual must remain with the vehicle. Additional or replacement manuals may be obtained by calling or writing Harsco Track Technologies, Harsco Corporation.

All information, illustrations and specifications in this manual are based on the latest information available at the time of publication. Harsco Track Technologies, Harsco Corporation reserves the right to make changes at any time without notice.

FACILITY LOCATIONS

Harsco Track Technologies

415 North Main Street
Fairmont, MN
56031-1837
Tel: (507) 235-3361
Fax: (507) 235-7370

Harsco Track Technologies

200 South Jackson Road
Ludington, MI
49431
Tel: (231) 843-3431
Fax: (231) 843-4830

Harsco Track Technologies

2401 Edmund Road, Box 20
Cayce-West Columbia, SC
29171-0020
Tel: (803) 822-9160
Fax: (803) 822-7471

Harsco Track Technologies

Giltway, Giltbrook
Nottingham, NG16 2GQ
England
Tel: 0115 938 7000
Fax: 0115 938 7001

Harsco Track Technologies

28 Eagle Road
Danbury, CT
06810
Tel: (203) 778-6811
Fax: (203) 778-8670

Harsco Track Technologies

4 Strathwyn Street, PO Box 5287
Brendale, Queensland 4500
Australia
Tel: 61 7 205 6500
Fax: 61 7 205 7369

TABLE OF CONTENTS

GENERAL INFORMATION

SECTION

1

OPERATION

SECTION

2

ADJUSTMENTS

SECTION

3

MAINTENANCE

SECTION

4

TROUBLESHOOTING

SECTION

5

APPENDICES

SECTION

6

PARTS

SECTION

7

VEHICLE APPLICATIONS

SECTION

8

SECTION

9

SECTION

10

**SECTION 1 - GENERAL INFORMATION
TABLE OF CONTENTS**

Safety Information

SAFETY INFORMATION 1 - 2

Identification View

IDENTIFICATION VIEW 1 - 5

Description

DESCRIPTION 1 - 6

Orientation

ORIENTATION 1 - 6

Serial Numbers

SERIAL NUMBERS 1 - 7

Specifications

VEHICLE 1 - 8
RAIL PILOT UNIT 1 - 8

1

Safety Information



SAFETY IS A CRITICAL FACTOR IN THE DESIGN OF HARSCO TRACK TECHNOLOGIES EQUIPMENT. THE BEST SAFETY PROGRAM STARTS WITH A SAFETY CONSCIOUS OPERATOR. THE SAFETY INFORMATION HIGHLIGHTED IN THIS BULLETIN DESCRIBES SAFE OPERATING PRACTICES FOR THE BENEFIT OF THE WORKERS WHO WILL USE OUR EQUIPMENT IN THEIR DAILY JOBS.

HAZARD SERIOUSNESS

Signal Words: **DANGER**, **WARNING** and **CAUTION** are used to identify levels of hazard seriousness.



DANGER - Immediate hazards which WILL result in sever bodily injury or death.



WARNING - Hazards or unsafe practices which COULD result in severe bodily injury or death.



CAUTION - Hazards or unsafe practices which COULD result in minor bodily injury and / or product or property damage.

Safety Information

1



- **APPLY THE VEHICLE PARKING BRAKE AND STOP THE ENGINE WHEN PERFORMING MAINTENANCE, MAKING ADJUSTMENTS, WORKING UNDER VEHICLE OR GUIDE WHEEL EQUIPMENT OR WHENEVER UNINTENDED MOVEMENT OF THE VEHICLE COULD OCCUR, UNLESS OTHERWISE INSTRUCTED IN THIS MANUAL.**
- **MAKE SURE ALL PERSONS ARE CLEAR OF VEHICLE BEFORE PERFORMING ANY OPERATING FUNCTIONS.**
- **KEEP ALL PARTS OF THE BODY AND LOOSE CLOTHING CLEAR OF ALL MOVING PARTS OF THE VEHICLE OR GUIDE WHEEL EQUIPMENT.**
- **UNDERSTAND EQUIPMENT OPERATION AND BE AWARE OF ALL PINCH POINTS BEFORE OPERATING OR MAKING ADJUSTMENTS TO GUIDE WHEEL EQUIPMENT.**
- **IF A DERAILMENT SHOULD OCCUR WHILE VEHICLE IS OPERATING IN ELECTRIFIED 3RD-RAIL TERRITORY, VEHICLE OR GUIDE WHEEL EQUIPMENT MIGHT BE IN ELECTRICAL CONTACT WITH ELECTRIFIED RAIL. DO NOT ATTEMPT TO EXIT FROM VEHICLE UNTIL ELECTRICAL POWER TO 3RD-RAIL HAS BEEN TURNED OFF.**
- **DO NOT EXCEED 25 MPH (40 km/h) WHEN OPERATING VEHICLE ON TRACK. RAILROAD RULES GOVERNING SPEEDS SHOULD BE OBSERVED AT ALL TIMES. REDUCE SPEED WHEN PROPELLING VEHICLE THROUGH SWITCHES, CROSSINGS, BRANCH LINES AND ANY SPECIAL TRACK WORKS. OPERATING VEHICLE AT UNSAFE SPEEDS COULD RESULT IN DERAILMENT OF VEHICLE.**
- **CHECK AND CORRECT GUIDE WHEEL EQUIPMENT ALIGNMENT PROMPTLY IF MISALIGNMENT IS INDICATED.**

Safety Information

1



- **AT MAXIMUM LOADED GROSS VEHICLE WEIGHT ON TRACK (including driver, passengers, equipment, tools, payload, etc.) DO NOT EXCEED ANY OF THE FOLLOWING:**
 - **VEHICLE'S G.V.W.R. (Gross Vehicle Weight Rating).**
 - **VEHICLE'S FRONT G.A.W.R. (Gross Axle Weight Rating) OR THE FRONT GUIDE WHEEL UNIT RATED LOAD CAPACITY, WHICHEVER IS LOWER.**
 - **VEHICLE'S REAR G.A.W.R. (Gross Axle Weight Rating) OR THE SUM OF THE REAR GUIDE WHEEL UNIT RATED LOAD CAPACITY PLUS (+) VEHICLE'S REAR TIRE/WHEEL RATED LOAD CAPACITY, WHICHEVER IS LOWER.**
 - **COMPONENTS RATED LOAD CAPACITY:**
 - A. **TIRE MANUFACTURER'S RATED LOAD CAPACITY**
 - B. **VEHICLE'S WHEEL RATED LOAD CAPACITY**
 - C. **FRONT GUIDE WHEEL UNIT RATED LOAD CAPACITY:**
 - 20,000 lbs (9,072 kg)
 - 10,000 lbs (4,536 kg) maximum per guide wheel

FAILURE TO HEED THESE WARNINGS COULD RESULT IN SEVERE BODILY INJURY.



- **OBSERVE AND FOLLOW ALL RAILROAD SAFETY RULES AND REGULATIONS.**
- **KNOW THE POSITIONS AND FUNCTIONS OF ALL CONTROLS BEFORE ATTEMPTING TO OPERATE VEHICLE.**
- **THIS GUIDE WHEEL EQUIPMENT IS DESIGNED WITH YOUR SAFETY IN MIND. NEVER DISCONNECT AND/OR ATTEMPT TO OVERRIDE SAFETY FEATURES.**

FAILURE TO HEED THESE PRECAUTIONS COULD RESULT IN BODILY INJURY AND/OR PROPERTY DAMAGE.

Note: To help ensure safe operation of this equipment, keep all safety decals clean and legible. Replace safety decals when necessary with new decals, listed in the Parts Section of this manual.

Identification View

FIGURE 1-1
HR4000 SERIES V FRONT
HY-RAIL® GUIDE WHEEL UNIT

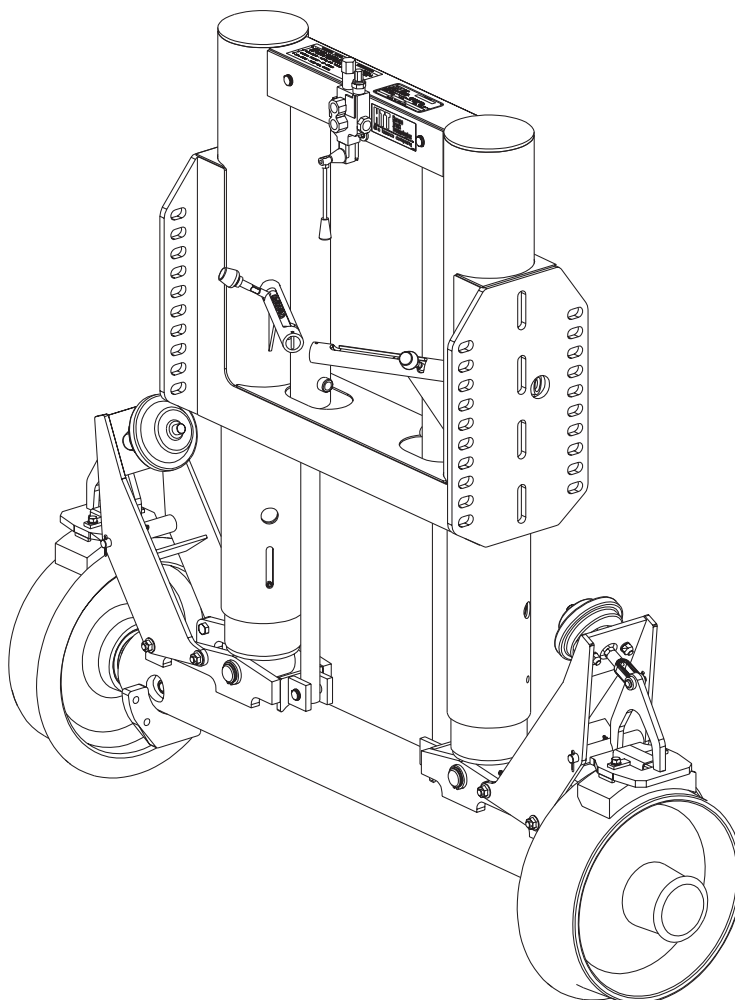

SE02A157A-1

Description

1

The HR4000 Series V HY-RAIL® guide wheel equipment can be applied to the front of various cab chassis trucks with single or tandem rear axles and dual wheels. The vehicle's G.V.W.R. (gross vehicle weight rating) and/or G.A.W.R. (gross axle weight rating) must comply with the specified limits listed in the Harsco Track Technologies HY-RAIL® Vehicle Specifications Manual. Vehicles should be equipped with bias ply tires. Radial tires are not recommended. For information regarding special applications not listed in the Harsco Track Technologies HY-RAIL® Vehicle Specifications Manual, contact Harsco Track Technologies, Harsco Corporation, Fairmont, Minnesota.

The guide wheel unit is raised and lowered hydraulically. Hydraulic power may be supplied from the vehicle system or from an optional power pack. The guide wheel unit is mounted onto the vehicle frame. When the guide wheels are in the "highway" position, the weight of the guide wheel unit is carried on the vehicle frame, above the springs. Load bearing guide wheels assemblies guide the vehicle during on track operation. An axle locking mechanism holds the vehicle front axle and tires above the rail surface to ensure that the tires do not come into contact with the rails while the vehicle is propelling through crossings, switches, etc. A steering lock is used during on track operation. The steering lock holds the vehicle's steering wheel in place to ensure the vehicle's front tires remain straight.

The vehicle's rear inner dual wheels are used for propulsion on the track. On track braking is provided by the vehicle's rear brakes, the front guide wheel unit's brakes and the rear guide wheel unit's brakes, if so equipped. Since the guide wheel unit brakes are air actuated, the vehicle on which the guide wheel equipment is mounted should be equipped with air brakes. If not, an electric / air system is available to provide air for the guide wheel unit brakes.

Vehicle Orientation

Front - rear and left - right are determined from the vehicle operator's seat.

Serial Numbers

When this bulletin is received, complete the following record from the serial number tag on the guide wheel unit. Always provide these factory serial numbers when calling or writing about the unit. The serial number tag is located on the frame assembly of the unit.

1

FIGURE 1-2
FRONT GUIDE WHEEL UNIT SERIAL NUMBER TAG

HTT Harsco Track Technologies a harsco company™		PATENT NUMBER <input type="text"/>
WHEN ORDERING PARTS FOR THIS ACCESSORY ALWAYS GIVE THE FOLLOWING INFORMATION		
Fairmont ™ HY-RAIL® GUIDE WHEEL EQUIPMENT		
SERIAL NUMBER <input type="text"/>	SYMBOL <input type="text"/>	MODEL NUMBER <input type="text"/>
FAIRMONT, MN. 56031 U.S.A.		
52400K		

Specifications

1

VEHICLE

See the Harsco Track Technologies HY-RAIL® Vehicle Specifications Manual for vehicle specifications. For information regarding special applications not listed in the Harsco Track Technologies Vehicle Specifications Manual, contact Harsco Track Technologies, Harsco Corporation, Fairmont, Minnesota.

GUIDE WHEEL UNIT

Track Gauge	56-1/2 in	(1435 mm)
Guide Wheels - Flange Diameter	18 in	(457 mm)
- Tread Diameter	16 in	(406 mm)
Weight		
Without Brakes	985 lbs	(447 kg)
With Brakes	1065 lbs	(483 kg)
Maximum Load Capacity	20,000 lbs	(9,072 kg)
(with vehicle at curb weight)		
Maximum Load Per Guide Wheel	10,000 lbs	(4,536 kg)
(with vehicle at curb weight)		

**SECTION 2 - OPERATION
TABLE OF CONTENTS**

Speedometer

SPEEDOMETER 2 - 4

Preparing For Operation

VEHICLE 2 - 4
GUIDE WHEEL EQUIPMENT 2 - 5

Misalignment Indicators

MISALIGNMENT INDICATORS 2 - 5

Placing Vehicle On Track

PLACING VEHICLE ON TRACK 2 - 6
LOWER FRONT GUIDE WHEELS 2 - 8
STEERING LOCKS 2 - 10
RAIL BRAKES 2 - 10

Guide Wheel Load On Track

CHECKING FRONT GUIDE WHEEL LOAD ON TRACK 2 - 11
CHECKING VEHICLE TIRE CLEARANCE ABOVE RAILS 2 - 12

Propelling On Track

PROPELLING ON TRACK 2 - 14

Braking On Track

BRAKING ON TRACK 2 - 15

Vehicles Equipped With Crane Or Aerial Lift Device

VEHICLES EQUIPPED WITH CRANE OR AERIAL LIFT DEVICE 2 - 16

Removing Vehicle From Track

REMOVING VEHICLE FROM TRACK 2 - 17
RAISE FRONT GUIDE WHEELS 2 - 18

Highway Operation

HIGHWAY OPERATION 2 - 20

Towing

2

TOWING TRAILER / EQUIPMENT WITH VEHICLE ON TRACK 2 - 21
TOWING TRAILER / EQUIPMENT WITH VEHICLE ON ROAD 2 - 24
TOWING DISABLED VEHICLE ON TRACK 2 - 27
TOWING DISABLED VEHICLE ON ROAD 2 - 30

Speedometer



- **WHEN WHEEL/TIRE MODIFICATIONS ARE APPLIED, CHECK AND CHANGE SPEEDOMETER DRIVE RATIO IF NECESSARY. THE SPEEDOMETER DRIVE RATIO WILL INFLUENCE THE OPERATION OF THE VEHICLE'S ANTI-LOCK BRAKE SYSTEMS, ELECTRONICALLY CONTROLLED TRANSMISSION SHIFT TIMING AND SPEEDOMETER DISPLAY OF THE TRUE VEHICLE SPEED. FAILURE TO MAINTAIN CORRECT SPEEDOMETER DRIVE RATIO COULD RESULT IN SEVERE BODILY INJURY.**

2

Some vehicles require special larger diameter wheels and/or wheel spacers to properly space the vehicle tires for on track operation. Use of these wheel modifications may effect the speedometer drive ratio calibration. The speedometer drive ratio will influence the operation of the vehicle's anti-lock brake systems, electronically controlled transmission shift timing and speedometer display of the true vehicle speed. The vehicle speedometer must be re-calibrated when wheel modifications are applied to the vehicle. See the vehicle manufacturer or dealer for speedometer calibration information.

Preparing for Operation

VEHICLE

Be sure the vehicle is in operating condition by checking the following:

- a. Engine oil level.
- b. Radiator fluid level.
- c. Fuel tank level.
- d. Hydraulic reservoir oil level.
- e. Brakes work properly.
- f. Parking brake works properly.
- g. Head, brake and signal lights work properly.
- h. Tires properly inflated to the manufacturer's recommended maximum pressure printed on the sidewall of the tires, or the wheel manufacturer's recommended maximum pressure stamped on the wheel, whichever is lower.
- i. Vehicle wheels: Lug nuts / bolts tightened to the proper torque, inspect vehicle wheels, lug bolts and lug nuts for wear or damage. For vehicle wheel, lug bolt and lug nut inspection information refer to the USER'S GUIDE TO WHEELS AND RIMS produced by THE MAINTENANCE COUNCIL. To obtain this guide, contact:

THE MAINTENANCE COUNCIL
AMERICAN TRUCKING ASSOCIATION
2200 MILL ROAD
ALEXANDRIA, VA. 22314
Phone: (703) 838-1763

- j. Any other normal maintenance requirements.

Preparing for Operation

GUIDE WHEEL EQUIPMENT

Be sure the guide wheel equipment is in operating condition by checking the following:

- a. Air and hydraulic hoses and fittings for damage, wear or leaks.
- b. Overall for damaged or worn parts.
- c. Properly lubricated at the recommended operating mileage intervals.
- d. Brakes work properly.
- e. Hydraulic pressure properly adjusted.

Misalignment Indicators



■ **BEFORE OPERATING A VEHICLE WITH NEWLY INSTALLED GUIDE WHEEL EQUIPMENT ON TRACK, VERIFY THAT THE GUIDE WHEEL EQUIPMENT ALIGNMENT PROCEDURE HAS BEEN COMPLETED. CHECK AND CORRECT ALIGNMENT PROMPTLY IF MISALIGNMENT IS INDICATED. MISALIGNMENT OF GUIDE WHEEL EQUIPMENT COULD RESULT IN DERAILMENT OF VEHICLE AND SEVERE BODILY INJURY.**

The following conditions may indicate that minor adjustments to the guide wheel equipment alignment are necessary. If any of these conditions occur during operation, perform the Track Test, see Adjustment Section - Vehicle Track Test and/or complete the Alignment Procedure, see Adjustment - Guide Wheel Equipment Alignment Procedure.

1. Excessive flange or tread wear on any of the rail guide wheels.
2. Vehicle pulls noticeably to the left or the right during on track operation.
3. Vibration felt throughout the vehicle at various speeds during on track operation.

Placing Vehicle On Track

2



- PLACE VEHICLE AUTOMATIC TRANSMISSION IN "PARK" OR MANUAL TRANSMISSION IN "NEUTRAL". APPLY THE PARKING BRAKE.
- UNDERSTAND EQUIPMENT OPERATION AND BE AWARE OF ALL PINCH POINTS BEFORE OPERATING OR MAKING ADJUSTMENTS TO GUIDE WHEEL EQUIPMENT.
- BEFORE PROPELLING VEHICLE ON THE TRACK, MAKE SURE:
 - FRONT AND REAR GUIDE WHEELS ARE LOWERED AND LOCKED IN RAIL POSITION, AND SECURED WITH LOCK PIN.
 - ALL RAIL GUIDE WHEEL FLANGES ARE ENGAGED ON INSIDE RAIL.
 - AXLE HOOKS ARE ENGAGED UNDER THE VEHICLE FRONT AXLE, HOLDING THE VEHICLE FRONT TIRES A MINIMUM OF 1-1/2" (38 mm) ABOVE THE RAIL.
 - STEERING WHEEL LOCK IS ENGAGED.
 - BRAKE CONTROL VALVE IS IN THE "ON" POSITION AND GUIDE WHEEL BRAKE EQUIPMENT IS FUNCTIONAL.

FAILURE TO HEED THESE WARNINGS COULD RESULT IN DERAILMENT OF VEHICLE AND SEVERE BODILY INJURY.



- WHEN USING VEHICLE MECHANICAL PTO HYDRAULIC PUMP TO LOWER GUIDE WHEEL EQUIPMENT, DO NOT EXCEED HYDRAULIC SYSTEM FLOW OF 8 GPM. EXCESSIVE FLOW COULD DAMAGE HYDRAULIC SYSTEM COMPONENTS
- OBSERVE AND FOLLOW ALL RAILROAD SAFETY RULES AND REGULATIONS.
- IF THE VEHICLE IS EQUIPPED WITH A STROBE LIGHT (BEACON) AND RAILROAD RULES AND REGULATIONS REQUIRE ITS USE, THE STROBE LIGHT (BEACON) MUST BE ILLUMINATED WHEN PLACING THE VEHICLE ON TRACK AND WHEN OPERATING THE VEHICLE ON TRACK.

FAILURE TO HEED THESE PRECAUTIONS COULD RESULT IN BODILY INJURY AND/OR PROPERTY DAMAGE.

Placing Vehicle On Track

1. Ensure that highway vehicles are not approaching the grade crossing while placing the vehicle on track. Flag the crossing per railroad rules and regulations to ensure safety.
2. At a road crossing, drive the vehicle about 25 feet (7.6 m) past the track. Back the vehicle onto the rails so that the rear vehicle wheels are centered on the rails. On vehicles with dual rear wheels, the inner dual wheels must be centered on the rails. It may be necessary to move the vehicle back and forth several times to get the wheels centered on the rail properly.
3. Place the vehicle automatic transmission in "PARK" or manual transmission in "NEUTRAL". Apply the parking brake.
4. Engage the mechanical PTO hydraulic pump or start the auxiliary hydraulic power source. If the vehicle is equipped with an auxiliary control valve, place the valve in the proper position to direct hydraulic oil flow to the guide wheel equipment.
5. Lower and lock the rear guide wheels first. The rear guide wheels should be lowered first so the front tires of the vehicle can be maneuvered to align the front guide wheels with the rails. See the Operator's Service And Parts Manual provided with the rear guide wheel unit for information on lowering the rear guide wheels.

Placing Vehicle On Track

LOWERING FRONT GUIDE WHEELS - See Figures 2-1, 2-2 and 2-3

2

1. Engage the axle hooks under the front axle. Pull control rod (1) out and lift up so that the collar on the rod can be moved through the large hole in plate (2). Push control rod (1) towards the vehicle until the axle hook is engaged under the axle. Repeat the procedure to engage the axle hook on the opposite side of the vehicle. Ensure that both axle hooks are fully engaged under the vehicle's axle.

Note: On some vehicle applications the axle hooks may be reversed and will engage under the axle from the rear instead of from the front. This will cause the axle hook control rod to engage and disengage the axle hooks in the opposite direction.

2. Lower and lock the guide wheels to the "rail" position. Rotate lock handles (3) up and pull out. Rotate the lock handles further up to engage them in the unlocked position. If necessary, slightly move the control valve handle (4) to raise or lower the guide wheels to release any tension on the lock pins so they will slide out of the lower hole in the spring cell tube.
3. Push control valve handle (4) towards the vehicle to lower the guide wheels. After the guide wheels have lowered a few inches, rotate lock handles (3) down to release them from the unlocked position. Continue to lower the guide wheels until the lock pins slide into the upper holes in the spring cell tubes. Push the lock pins fully in and rotate the lock handles (3) down to secure the lock pins in the locked position. Be sure the rail guide wheel flanges are engaged on the inside of the rails.
4. Push control valve handle (4) fully towards the vehicle to the "detent" position for rail travel.

Important: The lever must be in the "detent" position to allow the guide wheel unit suspension to operate properly.

5. Disengage the mechanical PTO hydraulic pump or stop the auxiliary hydraulic power source. If the vehicle is equipped with an auxiliary control valve, place the valve in the proper position to shut off hydraulic oil flow to the guide wheel equipment.

Placing Vehicle On Track

LOWERING FRONT GUIDE WHEELS

FIGURE 2-1
LOWERING FRONT GUIDE WHEELS

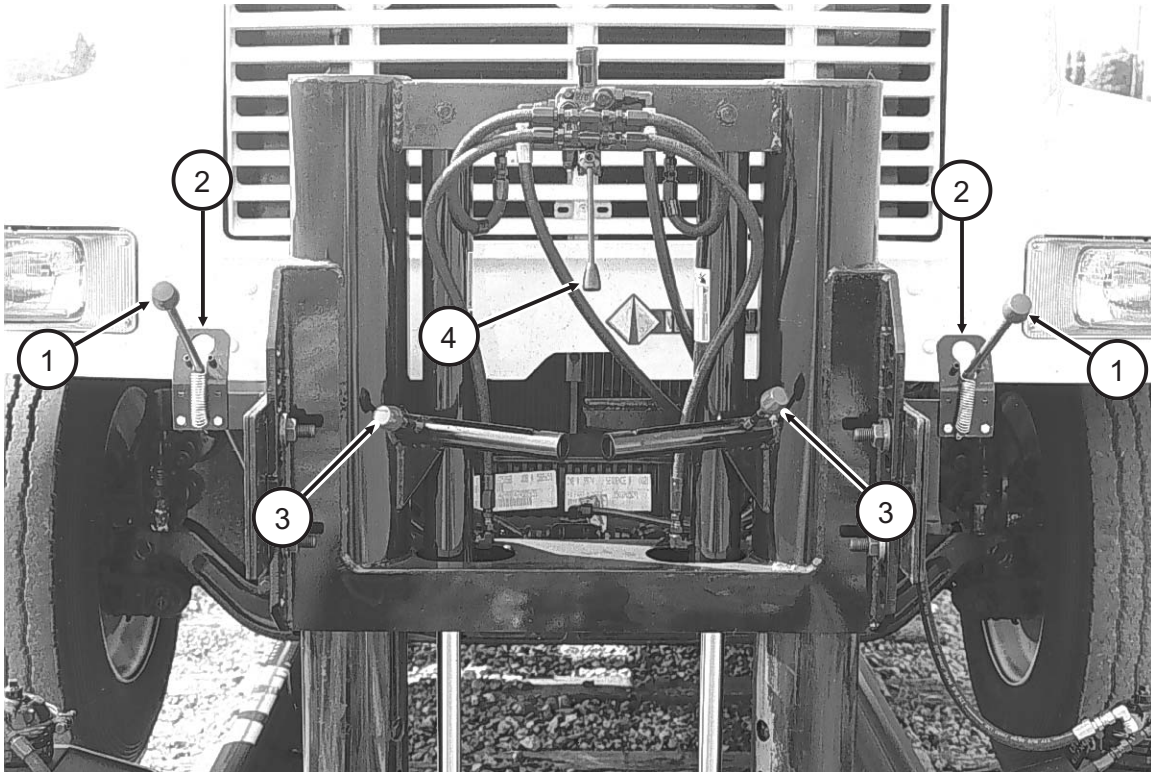

2

02-158

FIGURE 2-2
TO DISENGAGE LOCK

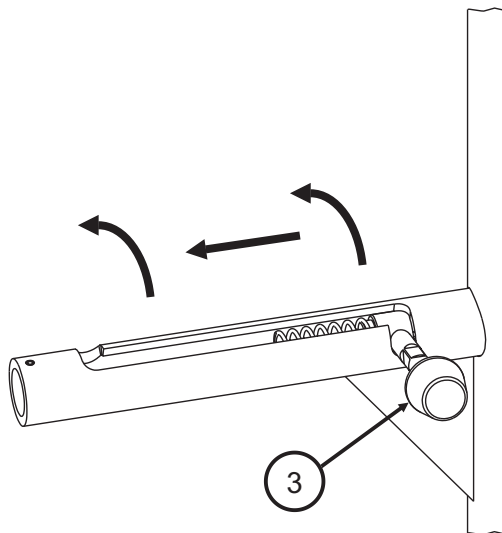

SE02A153A-1

FIGURE 2-3
TO ENGAGE LOCK

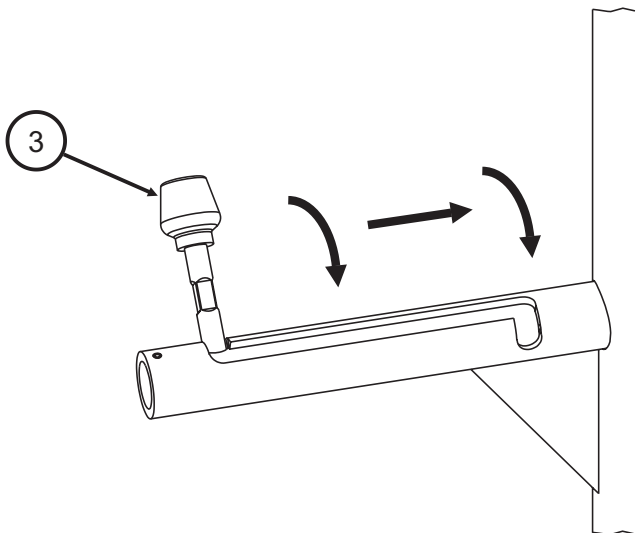

SE02A153A-2

Placing Vehicle On Track

STEERING LOCKS - See Figures 2-4 and 2-5

Set the vehicle front wheels straight ahead and secure the steering wheel in that position by engaging the steering lock on the steering column. Steering locks may vary from vehicle to vehicle but will operate similarly.

2

Note: Do not place your hands or any pressure on the steering wheel after the steering lock is engaged.

FIGURE 2-4
STEERING LOCK DISENGAGED

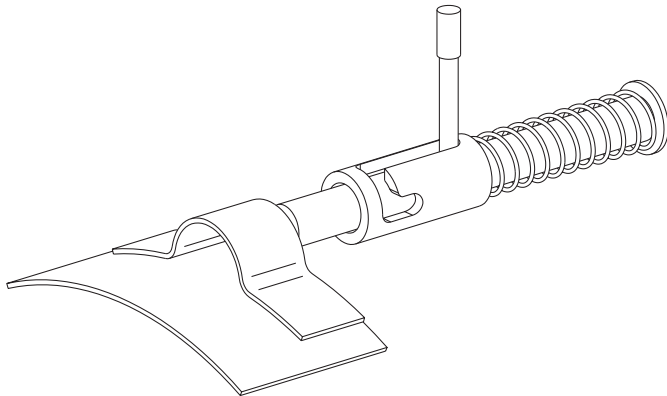

SE99A191A-1

FIGURE 2-5
STEERING LOCK ENGAGED

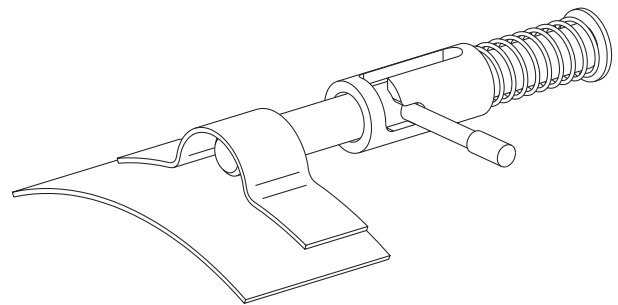

SE99A192A-1

RAIL BRAKES

Move the Rail Wheel Brake control valve to the ON position to activate the guide wheel equipment brakes whenever the vehicle is on track. The vehicle brake pedal will actuate the vehicle brakes and the guide wheel equipment brakes simultaneously.

Guide Wheel Load On Track



- **IMPROPER LOADING OF GUIDE WHEEL EQUIPMENT CAN CAUSE DERAILMENT OF VEHICLE.**
- **ALWAYS CHECK THE GUIDE WHEEL LOAD BEFORE OPERATING THE VEHICLE ON TRACK.**
- **NEVER OPERATE THE VEHICLE ON TRACK IF LOAD EXCEEDS THE MAXIMUM RATED LOAD OF THE FRONT AND/OR REAR GUIDE WHEEL UNITS. THE MAXIMUM LOAD ON THE FRONT GUIDE WHEEL UNIT IS 20,000 LBS (9,072 kg) OR 10,000 LBS (4,536 kg) MAXIMUM PER GUIDE WHEEL.**
- **NEVER OPERATE THE VEHICLE ON TRACK IF CLEARANCE BETWEEN VEHICLE FRONT TIRES AND RAIL IS LESS THAN 1-1/2" (38 mm).**

FAILURE TO HEED THESE WARNINGS COULD RESULT IN DERAILMENT OF VEHICLE AND/OR SEVERE BODILY INJURY.

Whenever the vehicle is loaded or additional load is added to the existing vehicle load on track, check the load on the front guide wheels. The maximum load on the front guide wheel unit is 20,000 lbs (9,072 kg) or 10,000 lbs (4,536 kg) maximum per guide wheel. Also, check the load on the rear guide wheel unit. See the Operator's Service And Parts Manual provided with the rear guide wheel unit for information on checking the load on the rear guide wheel unit.

CHECKING FRONT GUIDE WHEEL LOAD - See Chart 2-6 and Figures 2-7 and 2-8

To check the load on the front guide wheels it is necessary to measure the deflection of the coil springs in the guide wheel unit's suspension system. Use the following procedure to check the load on the front guide wheels. See Placing Vehicle On Track.

1. Engage the axle hooks under the front axle. Unlock and lower the guide wheels until they are slightly above the rails.
2. On the suspension tube on one side of the guide wheel unit, measure from the bottom of slot (1) to the bottom of roll pin (2). Record this dimension (A). Measure from the bottom of slot (1) to the bottom of roll pin (2) on the other suspension tube on the guide wheel unit. Record this dimension (B).
3. Fully lower and lock the guide wheels in the "rail" position. Make sure the control valve handle is fully rearward, in the "detent" position, so the vehicle's front end weight is on the guide wheel unit's suspension system.
4. On the first suspension tube checked, again measure from the bottom of slot (1) to the bottom of roll pin (2). Record this dimension (AA). Measure from the bottom of slot (1) to the bottom of roll pin (2) on the other suspension tube on the guide wheel unit. Record this dimension (BB).

Guide Wheel Load On Track

CHECKING FRONT GUIDE WHEEL LOAD - Continued

2

- 5. To determine the load on the guide wheel, subtract dimension (A) from dimension (AA) to obtain dimension (X), or subtract dimension (B) from dimension (BB) to obtain dimension (X).

Example: (AA) - (A) = dimension (X). See Chart 2-6 to convert dimension (X) into the approximate load on the guide wheel.

- 6 If the measured front guide wheel load exceeds the maximum load capacity, the load must be redistributed or some of the load removed. Never operate the vehicle on track if the load on the front guide wheel unit exceeds the maximum load capacity of 20,000 lbs (9,072 kg) or 10,000 lbs (4,536 kg) maximum per guide wheel.

**CHART 2-6
 FRONT GUIDE WHEEL LOAD**

DIMENSION X		APPROXIMATE LOAD PER SIDE	
1/8"	(3.2 mm)	891 lbs	(323 kg)
1/4"	(6.4 mm)	1,633 lbs	(562 kg)
3/8"	(9.5 mm)	2,374 lbs	(800 kg)
1/2"	(12.7 mm)	3,115 lbs	(1,038 kg)
5/8"	(15.9 mm)	3,856 lbs	(1,276 kg)
3/4"	(19.0 mm)	4,589 lbs	(1,514 kg)
7/8"	(22.2 mm)	5,339 lbs	(1,752 kg)
1"	(25.4 mm)	6,080 lbs	(1,990 kg)
1-1/8"	(28.6 mm)	6,821 lbs	(2,229 kg)
1-1/4"	(31.8 mm)	7,563 lbs	(2,467 kg)
1-3/8"	(34.9 mm)	8,304 lbs	(2,705 kg)
1-1/2"	(38.1 mm)	9,045 lbs	(2,943 kg)
1-5/8"	(41.3 mm)	9,786 lbs	(3,181 kg)
* 1-3/4"	(44.5 mm)	10,528 lbs	(3,181 kg)

* **FRONT GUIDE WHEEL IS OVERLOADED. REDISTRIBUTE OR REMOVE SOME OF THE LOAD. MAXIMUM LOAD ON FRONT GUIDE WHEEL UNIT MUST NOT EXCEED 20,000 LBS (9,072 kg) OR 10,000 LBS (4,536kg) MAXIMUM PER GUIDE WHEEL.**

CHECK VEHICLE FRONT TIRE CLEARANCE ABOVE RAIL

If the vehicle's front tire clearance above the rail is less than 1-1/2" (38 mm) see Adjustment Section - Vehicle Front Wheel Clearance. Never operate the vehicle on track when the front tire clearance above the rail is less than 1-1/2" (38 mm).

Guide Wheel Load On Track

FIGURE 2-7
MEASURING FOR CALCULATING GUIDE WHEEL LOAD

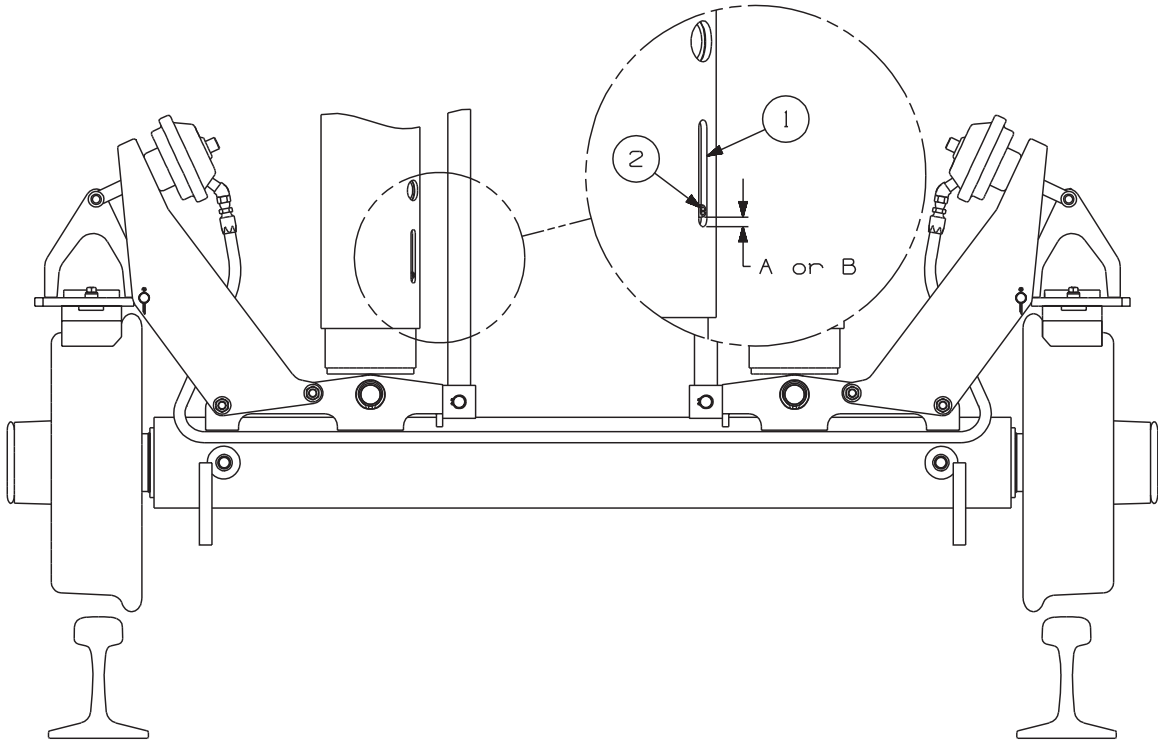

SE97A152A-1

FIGURE 2-8
MEASURING FOR CALCULATING GUIDE WHEEL LOAD

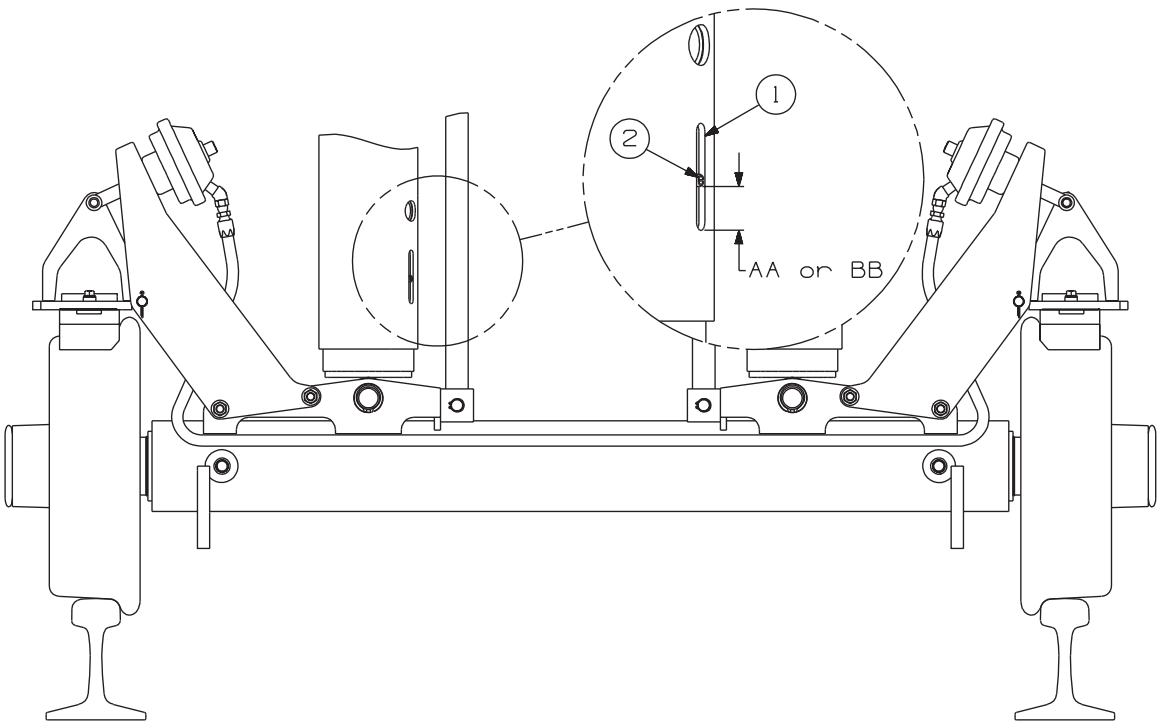

SE97A153A-1

Propelling On Track

2



- **IMPROPER LOADING OF HY-RAIL® EQUIPPED VEHICLE CAN CAUSE DERAILMENT OF VEHICLE.**
- **ALWAYS CHECK GUIDE WHEEL LOAD BEFORE OPERATING THE VEHICLE ON TRACK.**
- **NEVER OPERATE VEHICLE ON TRACK IF LOAD EXCEEDS MAXIMUM RATED LOAD OF FRONT AND/OR REAR GUIDE WHEEL UNITS.**
- **NEVER OPERATE VEHICLE ON TRACK IF CLEARANCE BETWEEN VEHICLE FRONT TIRE AND RAIL IS LESS THAN 1-1/2" (38 mm).**

FAILURE TO HEED THESE WARNINGS COULD RESULT IN DERAILMENT OF VEHICLE AND/OR SEVERE BODILY INJURY.



- **BEFORE OR WHEN PROPELLING ON TRACK:**
 - **OBSERVE AND FOLLOW ALL RAILROAD SAFETY RULES AND REGULATIONS.**
 - **OPERATOR MUST LOOK IN ALL DIRECTIONS FOR PERSONS OR OBJECTS ON OR ADJACENT TO THE TRACK.**
 - **DO NOT ACCELERATE SUDDENLY. TRACTION IS REDUCED ON TRACK, SPINNING VEHICLE TIRES COULD DAMAGE THEM.**
 - **DO NOT EXCEED 25 MPH (40 km/h) WHEN OPERATING VEHICLE ON TRACK. RAILROAD RULES GOVERNING SPEEDS SHOULD BE OBSERVED AT ALL TIMES. REDUCE SPEED WHEN PROPELLING VEHICLE THROUGH SWITCHES, ROAD CROSSINGS, BRANCH LINES AND ANY SPECIAL TRACK WORKS. OPERATING VEHICLE AT UNSAFE SPEEDS COULD RESULT IN DERAILMENT OF THE VEHICLE.**
 - **STEERING LOCK MUST BE ENGAGED AT ALL TIMES WHEN OPERATING VEHICLE ON TRACK.**
 - **IF THE VEHICLE IS EQUIPPED WITH A STROBE LIGHT (BEACON) AND RAILROAD RULES AND REGULATIONS REQUIRE ITS USE, THE STROBE LIGHT (BEACON) MUST BE ILLUMINATED WHEN OPERATING THE VEHICLE ON TRACK.**

FAILURE TO HEED THESE PRECAUTIONS COULD RESULT IN BODILY INJURY AND/OR PROPERTY DAMAGE.

Vehicles equipped with the HR4000 Series V HY-RAIL® Guide Wheel Equipment use the vehicle propulsion system to propel on track. Do not accelerate suddenly. Traction is reduced on track. Spinning the vehicle tires could damage them.

Braking On Track



- **PERSONS WHO OPERATE THE VEHICLE MUST BE FAMILIAR WITH TRACK AND WEATHER CONDITIONS THAT MAY AFFECT STOPPING DISTANCE. BE ALERT TO THESE CONDITIONS AND ALLOW ADEQUATE STOPPING DISTANCE.**
- **BE PREPARED TO BRAKE AT ALL HIGHWAY CROSSINGS. THIS VEHICLE MAY NOT OPERATE TRACK SIGNAL CIRCUITS, AND ONCOMING VEHICLES OR PEDESTRIANS MAY NOT YIELD THE RIGHT OF WAY.**
- **RAIL WHEEL BRAKE CONTROL VALVE MUST BE IN THE "ON" POSITION WHENEVER VEHICLE IS ON TRACK.**

FAILURE TO HEED THESE PRECAUTIONS COULD RESULT IN BODILY INJURY AND/OR PROPERTY DAMAGE.

The HR4000 Series V HY-RAIL® Guide Wheel Equipment may be equipped with brakes. If the guide wheel unit is equipped with brakes, the vehicle uses a combination of the front guide wheel unit brakes and the vehicle's rear axle brake system for braking on track. The front guide wheel unit brakes will apply simultaneously when the vehicle brakes are applied. Stopping distance is greater on track than on typical road surfaces. Apply the brakes gradually to avoid sliding the vehicle tires and rail guide wheels.

Vehicles Equipped With Crane Or Aerial Lift Device



2

- WHEN OPERATING CRANE, AERIAL LIFT DEVICE, ETC., WHILE THE VEHICLE'S GUIDE WHEELS ARE ON THE RAILS, DO NOT OVERLOAD THE GUIDE WHEEL EQUIPMENT OR EXCEED THE CAPACITY OF ANY OF THE EQUIPMENT BEING USED.
- THE UNIT SHOULD BE EQUIPPED WITH OUTRIGGERS TO HELP PREVENT ACCIDENTS AND THE POSSIBILITY OF DAMAGE TO THE GUIDE WHEEL EQUIPMENT. WHEN USING THE EQUIPMENT TO TRANSFER ANY LOAD, SET THE OUTRIGGERS ON A STABLE BASE TO PREVENT SETTLING OF THE OUTRIGGERS AND SHIFTING OF THE VEHICLE.
- IF OPERATING CONDITIONS REQUIRE LIFTING A LOAD WITH THE CRANE WHILE ON RAIL, BUT WITHOUT THE OUTRIGGERS BEING USED, THE LOAD APPLIED BY LIFTING WITH THE CRANE MUST NOT OVERLOAD ANY COMPONENT OF THE GUIDE WHEEL EQUIPMENT.
- CAREFULLY READ THE CRANE OR AERIAL LIFT DEVICE OPERATOR'S MANUAL FOR THE SAFE USE AND EFFICIENT OPERATION OF THE EQUIPMENT.

FAILURE TO HEED THESE WARNINGS COULD CAUSE DERAILMENT OF THE VEHICLE RESULTING IN SEVERE BODILY INJURY AND/OR DEATH.

Removing Vehicle From Track



- PLACE VEHICLE AUTOMATIC TRANSMISSION IN "PARK" OR MANUAL TRANSMISSION IN "NEUTRAL". APPLY THE PARKING BRAKE.

- UNDERSTAND EQUIPMENT OPERATION AND BE AWARE OF ALL PINCH POINTS BEFORE OPERATING OR MAKING ADJUSTMENTS TO GUIDE WHEEL EQUIPMENT.

- BEFORE PROPELLING VEHICLE OFF TRACK, MAKE SURE:

- FRONT AND REAR GUIDE WHEELS ARE RAISED, LOCKED IN THE HIGHWAY POSITION, AND SECURED WITH THE LOCK PINS.
- AXLE HOOKS ARE FULLY DISENGAGED FROM UNDER VEHICLE FRONT AXLE.
- STEERING WHEEL LOCK IS DISENGAGED.

FAILURE TO HEED THESE WARNINGS COULD RESULT IN SEVERE BODILY INJURY.



- WHEN USING VEHICLE MECHANICAL PTO HYDRAULIC PUMP TO RAISE GUIDE WHEEL EQUIPMENT, DO NOT EXCEED HYDRAULIC SYSTEM FLOW OF 8 GPM. EXCESSIVE FLOW COULD DAMAGE HYDRAULIC SYSTEM COMPONENTS

- OBSERVE AND FOLLOW ALL RAILROAD SAFETY RULES AND REGULATIONS.

- IF THE VEHICLE IS EQUIPPED WITH A STROBE LIGHT (BEACON) AND RAILROAD RULES AND REGULATIONS REQUIRE ITS USE, THE STROBE LIGHT (BEACON) MUST BE ILLUMINATED WHEN OPERATING AND REMOVING THE VEHICLE FROM TRACK.

FAILURE TO HEED THESE PRECAUTIONS COULD RESULT IN BODILY INJURY AND/OR PROPERTY DAMAGE.

Removing Vehicle From Track

1. Ensure that highway vehicles are not approaching the grade crossing while placing the vehicle on track. Flag the crossing per railroad rules and regulations to ensure safety.
2. Approach the crossing and stop with the vehicle front wheels on the crossing.
3. Place the vehicle automatic transmission in "PARK" or manual transmission in "NEUTRAL". Apply the parking brake.
4. Move the Rail Wheel Brake control valve to the OFF position, whenever the vehicle is removed from the track for highway use.
5. Engage the mechanical PTO hydraulic pump or start the auxiliary hydraulic power source. If the vehicle is equipped with an auxiliary control valve, place the valve in the proper position to direct hydraulic oil flow to the guide wheel equipment.

RAISING FRONT GUIDE WHEELS - See Figures 2-9, 2-10 and 2-11

1. Pull the control valve handle (4) forward, out of the "detent" position to the neutral position.
2. Unlock and raise the guide wheels to the "highway" position. Rotate lock handles (3) up and pull out. Rotate the lock handles further up to engage them in the unlocked position. If necessary, slightly move the control valve handle (4) to raise or lower the guide wheel unit to release any tension on the lock pins so they will slide out of the upper holes in the spring cell tubes.
3. Pull control valve handle (4) away from the vehicle to raise the guide wheels. After the guide wheels have raised a few inches, rotate lock handles (3) down to release them from the unlocked position. Continue to raise the guide wheels until the lock pins slide into the lower holes in the spring cell tubes. Push the lock pins fully in and rotate the lock handles (3) down to secure the lock pins in the locked position.
4. Disengage the axle hooks from under the front axle. Lift control rod (1) so that the collar on the rod can be moved through the large hole in plate (2). Pull control rod (1) out and lower it so the collar engages under the roll pins on plate (2). Repeat the procedure to disengage the axle hook on the opposite side of the vehicle. Ensure that both axle hooks are fully disengaged from under the vehicle's axle and that there is at least 3/4 inch (19 mm) of clearance between the axle hooks and the front axle.

Note: On some vehicle applications the axle hooks may be reversed and will engage under the axle from the rear instead of from the front. This will cause the axle hook control rod to engage and disengage the axle hooks in the opposite direction.

Removing Vehicle From Track

RAISING FRONT GUIDE WHEELS

FIGURE 2-9
RAISING FRONT GUIDE WHEELS

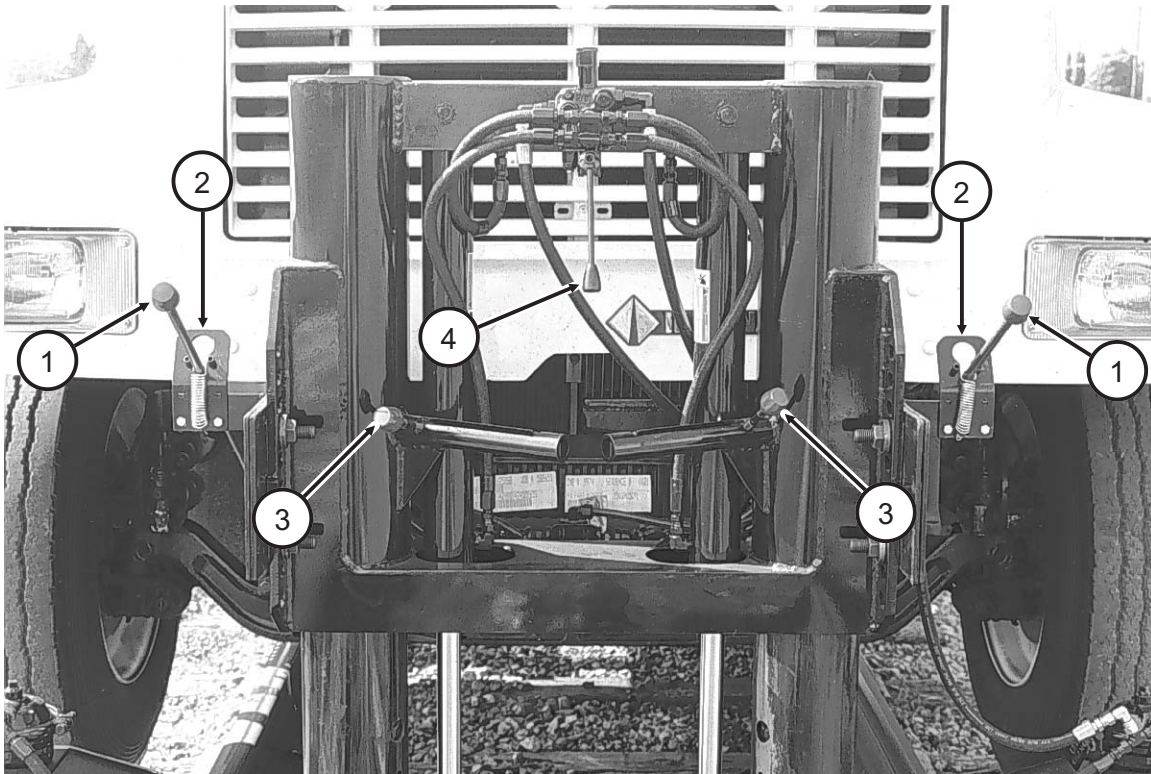

2

02-158

FIGURE 2-10
TO DISENGAGE LOCK

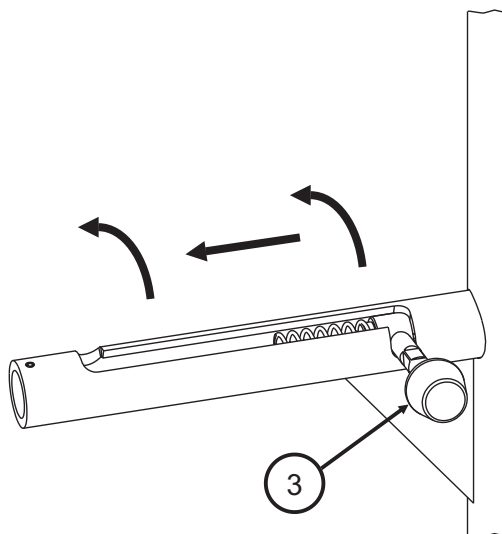

SE02A153A-1

FIGURE 2-11
TO ENGAGE LOCK

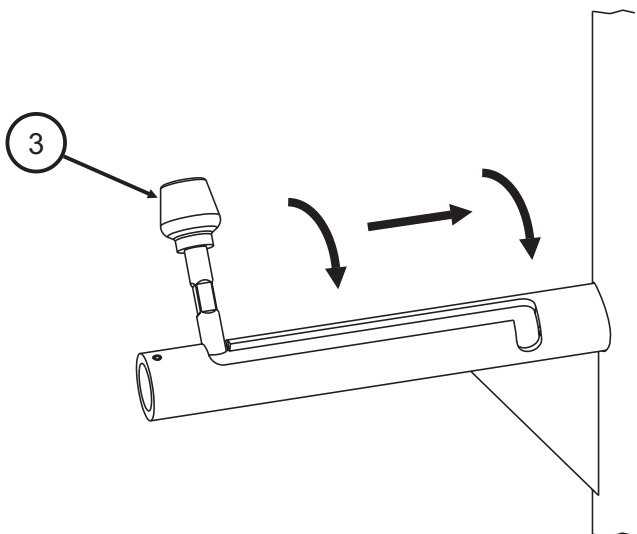

SE02A153A-2

Removing Vehicle From Track

5. Raise and lock the rear guide wheels in the "highway" position. See the Operator's Service And Parts Manual provided with the rear guide wheel unit for information on raising the rear guide wheels.
6. Disengage the mechanical PTO hydraulic pump or stop the auxiliary hydraulic power source. If the vehicle is equipped with an auxiliary control valve, place the valve in the proper position to shut off hydraulic oil flow to the guide wheel equipment.
7. See Figures 2-12 and 2-13. Disengage the vehicle steering lock located on the steering column. Steering locks may vary from vehicle to vehicle but will operate similarly.

FIGURE 2-12
STEERING LOCK DISENGAGED

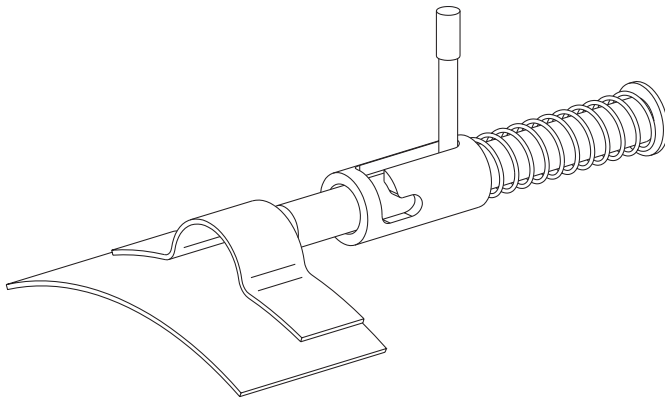

SE99A191A-1

FIGURE 2-13
STEERING LOCK ENGAGED

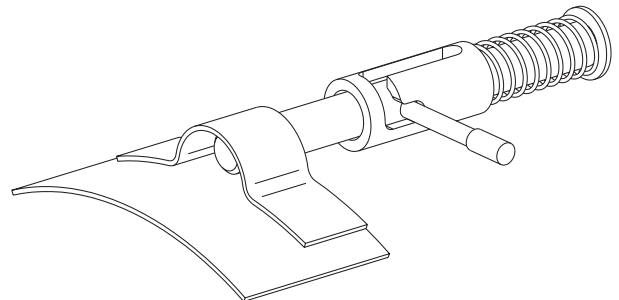

SE99A192A-1

Highway Operation



- THIS MULTIPURPOSE VEHICLE HAS SPECIAL DESIGN AND EQUIPMENT FEATURES FOR OFF-ROAD USE. IT HANDLES DIFFERENTLY FROM AN ORDINARY PASSENGER CAR IN DRIVING CONDITIONS WHICH MAY OCCUR ON STREETS, HIGHWAYS AND OFF-ROAD. WEIGHT AND LOCATION OF AVAILABLE PAYLOAD MAY ALSO AFFECT THE HANDLING OF THIS VEHICLE. DRIVE WITH CARE AND WEAR SAFETY BELTS AT ALL TIMES. READ VEHICLE OWNER'S MANUAL FOR ADDITIONAL PRECAUTIONS.

Towing Trailer / Equipment With Vehicle On Track



- VEHICLE USED FOR TOWING MUST BE RATED BY VEHICLE MANUFACTURER FOR WEIGHT OF TRAILER / EQUIPMENT TO BE TOWED. DO NOT EXCEED VEHICLE MANUFACTURER'S MAXIMUM RATED TOWING CAPACITY.
- TOWING VEHICLE MUST WEIGH AS MUCH OR MORE THAN TRAILER / EQUIPMENT BEING TOWED.
- VEHICLE USED FOR TOWING MUST HAVE AN ADEQUATE BRAKE SYSTEM TO SAFELY DECELERATE AND STOP TOWING VEHICLE AND TRAILER / EQUIPMENT BEING TOWED.
- TOWING TRAILER / EQUIPMENT LENGTHENS STOPPING DISTANCES. ALLOW ADEQUATE DISTANCE FOR STOPPING. ANTICIPATE STOPS SO YOU CAN BRAKE GRADUALLY.
- STOPPING DISTANCE IS GREATER ON TRACK THAN ON TYPICAL ROAD SURFACES. APPLY BRAKES GRADUALLY TO AVOID SLIDING VEHICLE TIRES AND GUIDE WHEELS.
- TOW TRAILER / EQUIPMENT AT A REASONABLE SPEED (20 MPH MAXIMUM) TAKING INTO ACCOUNT TRACK CONDITIONS, TRACK GRADE, WEATHER, VISIBILITY AND STOPPING DISTANCE TO ASSURE SAFE OPERATION. RAILROAD RULES GOVERNING SPEEDS AND RIGHT OF WAY SHOULD BE OBSERVED AT ALL TIMES.
- TRAILER / EQUIPMENT BEING TOWED MUST BE IN A SAFE, USABLE CONDITION TO BE TOWED.
- MAKE SURE THAT VEHICLE'S:
 - FRONT AND REAR GUIDE WHEEL ARE LOWERED AND LOCKED IN THE RAIL POSITION.
 - ALL GUIDE WHEEL FLANGES ARE ENGAGED ON INSIDE OF RAILS.
 - AXLE HOOKS MUST BE FULLY ENGAGED UNDER VEHICLE FRONT AXLE HOLDING VEHICLE FRONT TIRES A MINIMUM OF 1-1/2" (38 mm) ABOVE RAIL.
 - VEHICLE STEERING WHEEL LOCK ENGAGED WITH FRONT WHEELS STRAIGHT AHEAD.

FAILURE TO HEED THESE WARNINGS COULD RESULT IN SEVERE BODILY INJURY.

Towing Trailer / Equipment With Vehicle On Track



2

- CAREFULLY AND THOROUGHLY PREPARE VEHICLE FOR TOWING, MAKING SURE TO USE THE RIGHT TOWING EQUIPMENT AND TO ATTACH IT PROPERLY.
- TOWING EQUIPMENT (HITCHES, TOW BARS, ETC.) MUST BE ATTACHED TO VEHICLE FRAME. DO NOT MOUNT OR ATTACH TOWING EQUIPMENT TO VEHICLE'S GUIDE WHEEL EQUIPMENT.
- TOWING EQUIPMENT (HITCHES, TOW BARS, ETC.) MUST HAVE A RATED TOWING CAPACITY EQUAL TO OR GREATER THAN WEIGHT OF TRAILER / EQUIPMENT BEING TOWED.
- USE A RIGID TYPE TOW BAR WITH SAFETY LOCKING COUPLERS. DO NOT USE CHAIN, WIRE ROPE ETC.
- OBSERVE AND FOLLOW ALL RAILROAD SAFETY RULES AND REGULATIONS.
- DO NOT ACCELERATE SUDDENLY. TRACTION IS REDUCED ON RAIL, SPINNING VEHICLE TIRES COULD DAMAGE THEM.
- ALWAYS CHOCK TRAILER WHEELS BEFORE UNHOOKING TRAILER FROM TOWING VEHICLE.

FAILURE TO HEED THESE PRECAUTIONS COULD RESULT IN BODILY INJURY AND/OR PROPERTY DAMAGE.

Towing Trailer / Equipment With Vehicle On Track

1. See your vehicle's operators manual for towing information.
2. Use the vehicle manufacturer's recommendations to determine the maximum weight the towing vehicle can tow. Do not exceed vehicle manufacturer's maximum rated towing capacity.
3. The towing vehicle must have an adequate brake system to safely decelerate and stop the towing vehicle and the trailer / equipment being towed. The towing vehicle must weigh as much or more than the trailer / equipment being towed.
4. Make sure that the vehicle's:
 - a. Front and rear guide wheels are lowered and locked in the rail position.
 - b. All guide wheel flanges are engaged on the inside of the rails.
 - c. Axle hooks must be fully engaged under the vehicle front axle holding the vehicle front tires a minimum of 1-1/2" (38 mm) above the rail.
 - d. Vehicle front wheels are set straight ahead and the steering wheel lock is engaged on the steering column.
5. Make sure the towing vehicle and the trailer / equipment are in good working condition (tires, brakes, lights, etc.) and that current maintenance has been performed on the vehicle and trailer / equipment.
6. The towing equipment (hitches, tow bars, etc.) on the towing vehicle must have a rating equal to or greater than the weight of the trailer / equipment being towed.
7. The towing equipment (hitches, tow bars, etc.) must be attached to the towing vehicle frame. Do not mount or attach the towing equipment to the vehicle's guide wheel equipment.
8. Observe and follow all railroad safety rules and regulations.
9. Do not accelerate suddenly. Traction is reduced on rail. Spinning the vehicle tires could damage them.
10. Stopping distance is greater on rail than on typical road surfaces. Apply the vehicle brakes gradually to avoid sliding the vehicle tires and the guide wheels. Towing trailer / equipment lengthens stopping distances. Allow adequate distance for stopping. Anticipate stops so that you can brake gradually.
11. Tow the trailer / equipment on the track at a reasonable speed (20 MPH maximum) taking into account track conditions, track grade, weather, visibility and stopping distance to assure safe operation. Railroad rules and regulations governing speed limits and right of way should be observed at all times.
12. Always chock the trailer wheels before unhooking the trailer from the towing vehicle.

Towing Trailer / Equipment With Vehicle On Road



2

- VEHICLE USED FOR TOWING MUST BE RATED BY VEHICLE MANUFACTURER FOR WEIGHT OF TRAILER / EQUIPMENT TO BE TOWED. DO NOT EXCEED VEHICLE MANUFACTURER'S MAXIMUM RATED TOWING CAPACITY.
- VEHICLE USED FOR TOWING MUST HAVE AN ADEQUATE BRAKE SYSTEM TO SAFELY DECELERATE AND STOP TOWING VEHICLE AND TRAILER / EQUIPMENT BEING TOWED.
- TOWING TRAILER / EQUIPMENT LENGTHENS STOPPING DISTANCES. ALLOW ADEQUATE DISTANCE FOR STOPPING. ANTICIPATE STOPS SO YOU CAN BRAKE GRADUALLY.
- TOW TRAILER / EQUIPMENT AT A REASONABLE SPEED TAKING INTO ACCOUNT ROAD CONDITIONS, ROAD GRADE, WEATHER, VISIBILITY AND STOPPING DISTANCE TO ASSURE SAFE OPERATION. POSTED SPEED LIMITS SHOULD BE OBSERVED AT ALL TIMES.
- TRAILER / EQUIPMENT BEING TOWED MUST BE IN A SAFE, USABLE CONDITION TO BE TOWED.
- MAKE SURE THAT VEHICLE'S:
 - FRONT AND REAR GUIDE WHEELS ARE RAISED AND LOCKED IN HIGHWAY POSITION.
 - AXLE HOOKS MUST BE FULLY DISENGAGED FROM UNDER VEHICLE FRONT AXLE.
 - VEHICLE STEERING WHEEL LOCK DISENGAGED.

FAILURE TO HEED THESE WARNINGS COULD RESULT IN SEVERE BODILY INJURY.

Towing Trailer / Equipment With Vehicle On Road



■ THIS MULTIPURPOSE VEHICLE HAS SPECIAL DESIGN AND EQUIPMENT FEATURES FOR OFF-ROAD USE. IT HANDLES DIFFERENTLY FROM AN ORDINARY PASSENGER CAR IN DRIVING CONDITIONS WHICH MAY OCCUR ON STREETS, HIGHWAYS AND OFF-ROAD. WEIGHT AND LOCATION OF AVAILABLE PAYLOAD MAY ALSO AFFECT THE HANDLING OF THIS VEHICLE. DRIVE WITH CARE AND WEAR SAFETY BELTS AT ALL TIMES. READ VEHICLE OWNER'S MANUAL FOR ADDITIONAL PRECAUTIONS.

■ OBSERVE AND FOLLOW ALL FEDERAL, STATE AND LOCAL DRIVING RULES AND REGULATIONS.

■ STATE LAWS MAY REQUIRE TOWING VEHICLE AND TRAILER / EQUIPMENT BEING TOWED TO BE EQUIPPED WITH SPECIAL SAFETY EQUIPMENT (MIRRORS ON BOTH SIDES OF TOWING VEHICLE, TRAILER BRAKES, TRAILER LIGHTS, ETC.).

■ CAREFULLY AND THOROUGHLY PREPARE YOUR VEHICLE FOR TOWING, MAKING SURE TO USE THE RIGHT TOWING EQUIPMENT AND TO ATTACH IT PROPERLY.

■ TOWING EQUIPMENT (HITCHES, TOW BARS, ETC.) MUST BE ATTACHED TO VEHICLE FRAME. DO NOT MOUNT OR ATTACH TOWING EQUIPMENT TO VEHICLE'S GUIDE WHEEL EQUIPMENT.

■ TOWING EQUIPMENT (HITCH, TOW BAR, ETC.) MUST HAVE A RATED TOWING CAPACITY EQUAL TO OR GREATER THAN WEIGHT OF TRAILER / EQUIPMENT BEING TOWED.

■ ALWAYS CHOCK TRAILER WHEELS BEFORE UNHOOKING TRAILER FROM TOWING VEHICLE.

FAILURE TO HEED THESE PRECAUTIONS COULD RESULT IN BODILY INJURY AND/OR PROPERTY DAMAGE.

Towing Trailer / Equipment With Vehicle On Road

1. See your vehicle's operators manual for towing information.
2. Use the vehicle manufacturer's recommendations to determine the maximum weight the towing vehicle can tow. Do not exceed vehicle manufacturer's maximum rated towing capacity.
3. The towing vehicle must have an adequate brake system to safely decelerate and stop the towing vehicle and the trailer / equipment being towed. Towing trailer / equipment lengthens stopping distances. Allow adequate distance for stopping. Anticipate stops so that you can brake gradually.
4. Make sure that the vehicle's:
 - a. Front and rear guide wheels are raised and locked in the highway position.
 - b. Axle hooks must be fully disengaged from under the vehicle front axle.
 - c. Vehicle steering wheel lock is disengaged on the steering column.
5. Make sure the towing vehicle and the trailer / equipment are in good working condition (tires, brakes, lights, etc.) and that current maintenance has been performed on the vehicle and trailer / equipment.
6. The towing equipment (hitches, tow bars, etc.) on the towing vehicle must have a rating equal to or greater than the weight of the trailer / equipment being towed.
7. The towing equipment (hitches, tow bars, etc.) must be attached to the towing vehicle frame. Do not mount or attach the towing equipment to the vehicle's guide wheel equipment.
8. Observe and follow all federal, state and local driving rules, regulations and laws.
9. State laws may require the towing vehicle and/or the trailer / equipment being towed to be equipped with special safety equipment (mirrors on both sides of the towing vehicle, trailer brakes, trailer lights, etc.).
10. Tow the trailer / equipment on the road at a reasonable speed taking into account road conditions, road grade, weather, visibility and stopping distance to assure safe operation. Always observe posted speed limits.
11. Always chock the trailer wheels before unhooking the trailer from the towing vehicle.

Towing Disabled Vehicle On Track



- TOWING VEHICLE / MACHINE MUST WEIGH AS MUCH OR MORE THAN DISABLED VEHICLE BEING TOWED.
- VEHICLE / MACHINE USED FOR TOWING MUST HAVE AN ADEQUATE BRAKE SYSTEM TO SAFELY DECELERATE AND STOP TOWING VEHICLE / MACHINE AND DISABLED VEHICLE BEING TOWED.
- TOWING DISABLED VEHICLE LENGTHENS STOPPING DISTANCES. ALLOW ADEQUATE DISTANCE FOR STOPPING. ANTICIPATE STOPS SO YOU CAN BRAKE GRADUALLY.
- TOW DISABLED VEHICLE AT A REASONABLE SPEED (10 MPH MAXIMUM) TAKING INTO ACCOUNT TRACK CONDITIONS, TRACK GRADE, WEATHER, VISIBILITY AND STOPPING DISTANCE TO ASSURE SAFE OPERATION. RAILROAD RULES GOVERNING SPEED LIMITS AND RIGHT OF WAY SHOULD BE OBSERVED AT ALL TIMES.
- STOPPING DISTANCE IS GREATER ON TRACK THAN ON TYPICAL ROAD SURFACES. APPLY BRAKES GRADUALLY TO AVOID SLIDING TOWING VEHICLE / MACHINE WHEELS.
- MAKE SURE THAT DISABLED VEHICLE'S:
 - FRONT AND REAR GUIDE WHEELS ARE LOWERED AND LOCKED IN RAIL POSITION.
 - ALL GUIDE WHEEL FLANGES ARE ENGAGED ON INSIDE OF RAILS.
 - AXLE HOOKS MUST BE FULLY ENGAGED UNDER VEHICLE FRONT AXLE HOLDING VEHICLE FRONT TIRES A MINIMUM OF 1-1/2" (38 mm) ABOVE RAIL.
 - VEHICLE STEERING WHEEL LOCK ENGAGED WITH FRONT WHEELS STRAIGHT AHEAD.

FAILURE TO HEED THESE WARNINGS COULD RESULT IN SEVERE BODILY INJURY.

Towing Disabled Vehicle On Track



2

- TOW BAR MUST BE ATTACHED TO DISABLED VEHICLE'S FRAME. DO NOT MOUNT OR ATTACH TOW BAR TO DISABLED VEHICLE'S GUIDE WHEEL EQUIPMENT.
- TOW BAR MUST HAVE A RATED TOWING CAPACITY EQUAL TO OR GREATER THAN WEIGHT OF DISABLED VEHICLE BEING TOWED.
- USE A RIGID TYPE TOW BAR WITH SAFETY LOCKING COUPLERS. DO NOT USE CHAIN, WIRE ROPE ETC.
- OBSERVE AND FOLLOW ALL RAILROAD SAFETY RULES AND REGULATIONS.
- DO NOT ACCELERATE SUDDENLY. TRACTION IS REDUCED ON RAIL, SPINNING TOWING VEHICLE / MACHINE WHEELS COULD DAMAGE THEM.
- TOW DISABLED VEHICLE TO NEAREST ROAD CROSSING AND REMOVE FROM TRACK.

FAILURE TO HEED THESE PRECAUTIONS COULD RESULT IN BODILY INJURY AND/OR PROPERTY DAMAGE.

Towing Disabled Vehicle On Track

1. See your vehicle's operators manual for towing information.
2. The towing vehicle / machine must have an adequate brake system to safely decelerate and stop the towing vehicle / machine and the disabled vehicle being towed. The towing vehicle / machine must weigh as much or more than the disabled vehicle towed.
3. Make sure that the disabled vehicle's:
 - a. Front and rear guide wheels are lowered and locked in the rail position.
 - b. All guide wheel flanges are engaged on the inside of the rails.
 - c. Axle hooks must be fully engaged under the vehicle front axle holding the vehicle front tires a minimum of 1-1/2" (38 mm) above the rail.
 - d. Vehicle front wheels are set straight ahead and the steering wheel lock is engaged on the steering column.
4. Make sure the towing vehicle / machine is in good working condition (tires, brakes, lights, etc.) and that current maintenance has been performed on the vehicle / machine.
5. The towing equipment (hitches, tow bars, etc.) on the towing vehicle / machine must have a rating equal to or greater than the weight of the disabled vehicle being towed.
6. The tow bar must be mounted or attached to the disabled vehicle's frame. Do not mount or attach the tow bar to the disabled vehicle's guide wheel equipment. Use a rigid type tow bar with safety locking couplers.
7. Observe and follow all railroad safety rules and regulations.
8. Do not accelerate suddenly. Traction is reduced on rail. Spinning the towing vehicle tires / machine wheels could damage them.
9. Stopping distance is greater on rail than on typical road surfaces. Apply the towing vehicle / machine brakes gradually to avoid sliding the vehicle tires / machine wheels. Towing disabled vehicle lengthens stopping distances. Allow adequate distance for stopping. Anticipate stops so that you can brake gradually.
10. Tow the disabled vehicle on the track at a reasonable speed (10 MPH maximum) taking into account track conditions, track grade, weather, visibility and stopping distance to assure safe operation. Railroad rules and regulations governing speed limits and right of way should be observed at all times.
11. Tow the disabled vehicle to the nearest road crossing and remove the vehicle from the track.

Towing Disabled Vehicle On Road

2



- TOW DISABLED VEHICLE PER VEHICLE MANUFACTURER'S TOWING SPECIFICATIONS LISTED IN YOUR VEHICLE'S OPERATORS MANUAL.

- VEHICLE USED FOR TOWING MUST HAVE AN ADEQUATE BRAKE SYSTEM TO SAFELY DECELERATE AND STOP TOWING VEHICLE AND DISABLED VEHICLE BEING TOWED.

- TOW DISABLED VEHICLE AT A REASONABLE SPEED TAKING INTO ACCOUNT ROAD CONDITIONS, ROAD GRADE, WEATHER, VISIBILITY AND STOPPING DISTANCE TO ASSURE SAFE OPERATION. POSTED SPEED LIMITS SHOULD BE OBSERVED AT ALL TIMES.

- MAKE SURE DISABLED VEHICLE'S:
 - FRONT AND REAR GUIDE WHEELS ARE RAISED AND LOCKED IN HIGHWAY POSITION.
 - AXLE HOOKS MUST BE FULLY DISENGAGED FROM UNDER VEHICLE FRONT AXLE.
 - VEHICLE STEERING WHEEL LOCK DISENGAGED.

FAILURE TO HEED THESE WARNINGS COULD RESULT IN SEVERE BODILY INJURY.



- TOWING EQUIPMENT (TOW TRUCK, TOW BARS, ETC.) MUST BE ATTACHED TO DISABLED VEHICLE'S FRAME. DO NOT MOUNT OR ATTACH TOWING EQUIPMENT TO DISABLED VEHICLE'S GUIDE WHEEL EQUIPMENT.

- TOWING EQUIPMENT (TOW TRUCK, TOW BARS, ETC.) MUST HAVE A RATED TOWING CAPACITY EQUAL TO OR GREATER THAN WEIGHT OF DISABLED VEHICLE BEING TOWED.

- OBSERVE AND FOLLOW ALL FEDERAL, STATE AND LOCAL DRIVING RULES AND REGULATIONS.

- STATE LAWS MAY REQUIRE TOWING VEHICLE AND DISABLED VEHICLE TO BE EQUIPPED WITH SPECIAL SAFETY EQUIPMENT (LIGHTS, ETC.).

FAILURE TO HEED THESE PRECAUTIONS COULD RESULT IN BODILY INJURY AND/OR PROPERTY DAMAGE.

Towing Disabled Vehicle On Road

1. See your vehicle's operators manual for towing information.
2. The towing vehicle must have an adequate brake system to safely decelerate and stop the towing vehicle and the disabled vehicle being towed.
3. Make sure that the disabled vehicle's:
 - a. Front and rear guide wheels are raised and locked in the highway position.
 - b. Axle hooks must be fully disengaged from under the vehicle front axle.
 - c. Vehicle steering wheel lock is disengaged on the steering column.
4. Make sure the towing vehicle is in good working condition (tires, brakes, lights, etc.) and that current maintenance has been performed on the vehicle.
5. The towing equipment (tow truck, tow bars, etc.) on the towing vehicle must have a rating equal to or greater than the weight of the disabled vehicle being towed.
6. The towing equipment (tow truck, tow bars, etc.) must be mounted or attached to the disabled vehicle's frame. Do not mount or attach the towing equipment to the disabled vehicle's guide wheel equipment.
7. Observe and follow all federal, state and local driving rules, regulations and laws.
8. State laws may require the towing vehicle and disabled vehicle being towed to be equipped with special safety equipment (lights, etc.).
9. Tow the disabled vehicle on the road at a reasonable speed taking into account road conditions, road grade, weather, visibility and stopping distance to assure safe operation. Always observe posted speed limits.

**SECTION 3 - ADJUSTMENTS
TABLE OF CONTENTS**

Guide Wheel Equipment Alignment Procedure

VEHICLE CHECK	3 - 3
PLACING VEHICLE ON TRACK	3 - 4
GUIDE WHEEL TRACK GAUGE	3 - 5
GUIDE WHEEL LOAD ON TRACK	3 - 5
STRING LINING SET-UP	3 - 7
FRONT GUIDE WHEEL ALIGNMENT	3 - 9
VEHICLE TRACK TEST	3 - 14

Adjustments

VEHICLE FRONT TIRE CLEARANCE - RAIL POSITION	3 - 16
AXLE HOOK CLEARANCE - HIGHWAY POSITION	3 - 18
BRAKE SHOE CLEARANCE	3 - 20
RAIL SWEEP GROUP - SWEEP CLEARANCE	3 - 22

Guide Wheel Equipment Alignment Procedure



■ **ENGINE MUST BE RUNNING TO OPERATE MECHANICAL PTO HYDRAULIC PUMP TO RAISE / LOWER THE GUIDE WHEELS. BEFORE PERFORMING ANY ADJUSTMENTS TO GUIDE WHEEL EQUIPMENT OR VEHICLE, ALWAYS PLACE AUTOMATIC TRANSMISSION IN "PARK" OR MANUAL TRANSMISSION IN "NEUTRAL". APPLY THE PARKING BRAKE. FAILURE TO COMPLY COULD RESULT IN SEVERE BODILY INJURY.**

3

The Guide Wheel Alignment Procedure must be completed when the guide wheel equipment is applied to the vehicle, or when any of the misalignment indicators occur. See Operation - Misalignment Indicators.

See The Operator's Service and Parts Manual provided with the rear guide wheel unit for the proper alignment procedure for the rear guide wheel unit.

VEHICLE CHECK

1. The vehicle must be at curb weight with permanent attachments: spare tire, tool box less tools, utility box, crane, aerial lift boom, etc. and without: passengers, baggage, load, etc.
2. Weigh the entire vehicle and record this weight. Weigh both the front and rear axles of the vehicle separately and record these weights. These weights will be used when calculating the guide wheel load.
3. Permanent attachments to the vehicle such as a tool box, utility box, crane, aerial lift boom, etc. which could cause uneven loading on the guide wheels should be compensated for, by adjusting the vehicle suspension by adding leaf springs, coil springs, torsion bars, etc.
4. Tires must be inflated to the tire manufacturer's recommended maximum pressure printed on the sidewalls of the tires or wheel manufacturer's recommended maximum pressure, stamped on the wheel, whichever is lower.
5. Visually inspect the entire vehicle, especially the guide wheel equipment, for loose or missing bolts, and bent or damaged components. Tighten, repair, or replace as necessary.
6. Verify that the vehicle the guide wheel equipment is to be mounted to is equipped correctly (springs, tires, wheels, etc.). See the Harsco Track Technologies HY-RAIL® Vehicle Specifications Manual.

Guide Wheel Equipment Alignment Procedure

VEHICLE CHECK

3

7. Check the following measurements on the vehicle that the guide wheel equipment is to be mounted on before applying the guide wheel equipment to the vehicle.
 - a. Frame must be square. Diagonal measurements of the frame should be equal within 1/8 inch (3.2 mm).
 - b. Wheelbase (as measured on each side) must be equal within 1/16 inch (1.8 mm).
 - c. Vehicle axles must be square with the frame within 1/64 inch per foot (.4 mm per 304 mm). Harsco Track Technologies, Harsco Corporation recommends that this be checked by a reputable alignment shop.
8. Follow the mounting instructions on the application drawings which are supplied with each Guide Wheel Equipment Group.
9. After mounting the guide wheel equipment to the vehicle, have the caster, camber, and toe-in checked on the vehicle front wheels. If necessary, adjust to vehicle manufacturer's recommendations.
10. Have the headlight aim checked and adjusted, if necessary.

PLACING VEHICLE ON TRACK

1. Place the vehicle on straight, level, tangent track or an alignment rack constructed for guide wheel equipment alignment. If track or an alignment rack is not available, use 4 x 4 inch lumber on a level floor to simulate track. Space the lumber so it measures 56-1/2 inches (1.435 m) between the inside edges.
2. Place the vehicle automatic transmission in "Park" or manual transmission in "Neutral". Apply the parking brake. Lower and lock the guide wheels in the rail position. See Operation - Placing Vehicle On Track.
3. Set the vehicle front wheels straight ahead. Secure the steering wheel using the steering lock. Stop the engine.

Guide Wheel Equipment Alignment Procedure

GUIDE WHEEL TRACK GAUGE - See Figure 3-1

1. Measure the track gauge of the front guide wheel unit. Measure from the back of the left wheel flange, directly below the center line of the wheel spindle, to the same point on the right wheel flange. This dimension must be 53-1/4 to 53-3/8 inches (1352 mm to 1330 mm). The track gauge is preset at the factory and is non-adjustable.

FIGURE 3-1
GUIDE WHEEL TRACK GAUGE

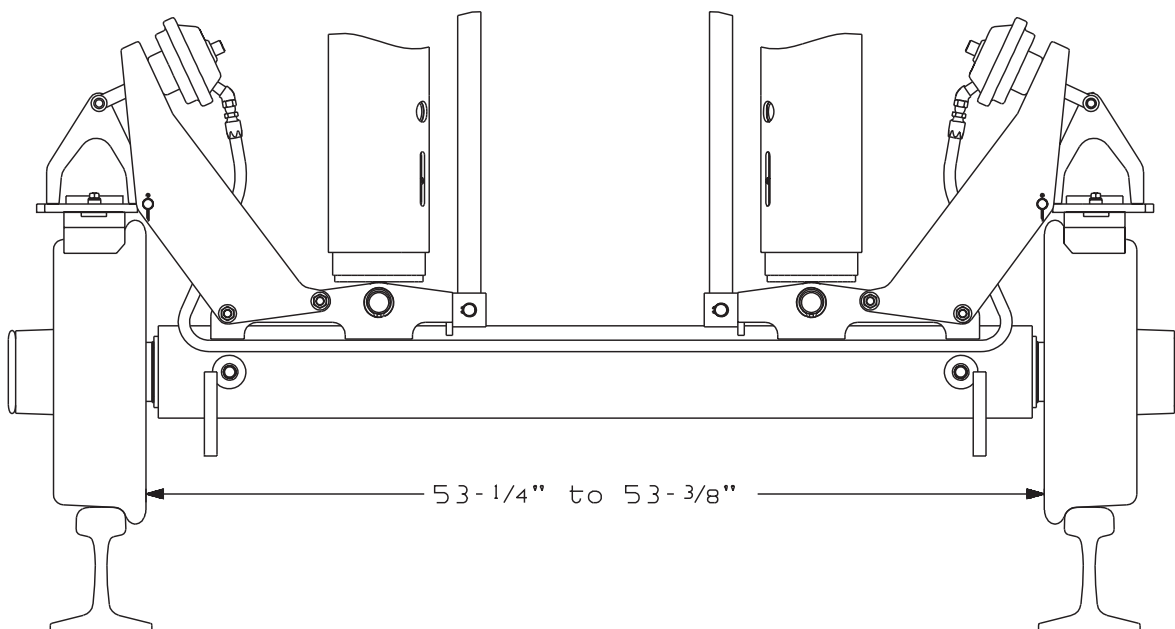

SE97A154A-1

GUIDE WHEEL LOAD

Front Guide Wheel Load On Track

1. The front guide wheel unit load capacity on track is non-adjustable. Whenever the vehicle is loaded or additional load is added to the existing vehicle load on track, check the load on the front guide wheels. The maximum load on the front guide wheel unit is 20,000 lbs (9,072 kg) or 10,000 lbs (4,536 kg) maximum per guide wheel.
2. To check the load on the front guide wheels it is necessary to measure the deflection of the coil springs in the guide wheel unit's suspension system. See the Operation Section - Guide Wheel Load On Track, Checking Front Guide Wheel Load, for the proper procedure.

Guide Wheel Equipment Alignment Procedure

**FIGURE 3-2
GUIDE WHEEL EQUIPMENT ALIGNMENT**

3

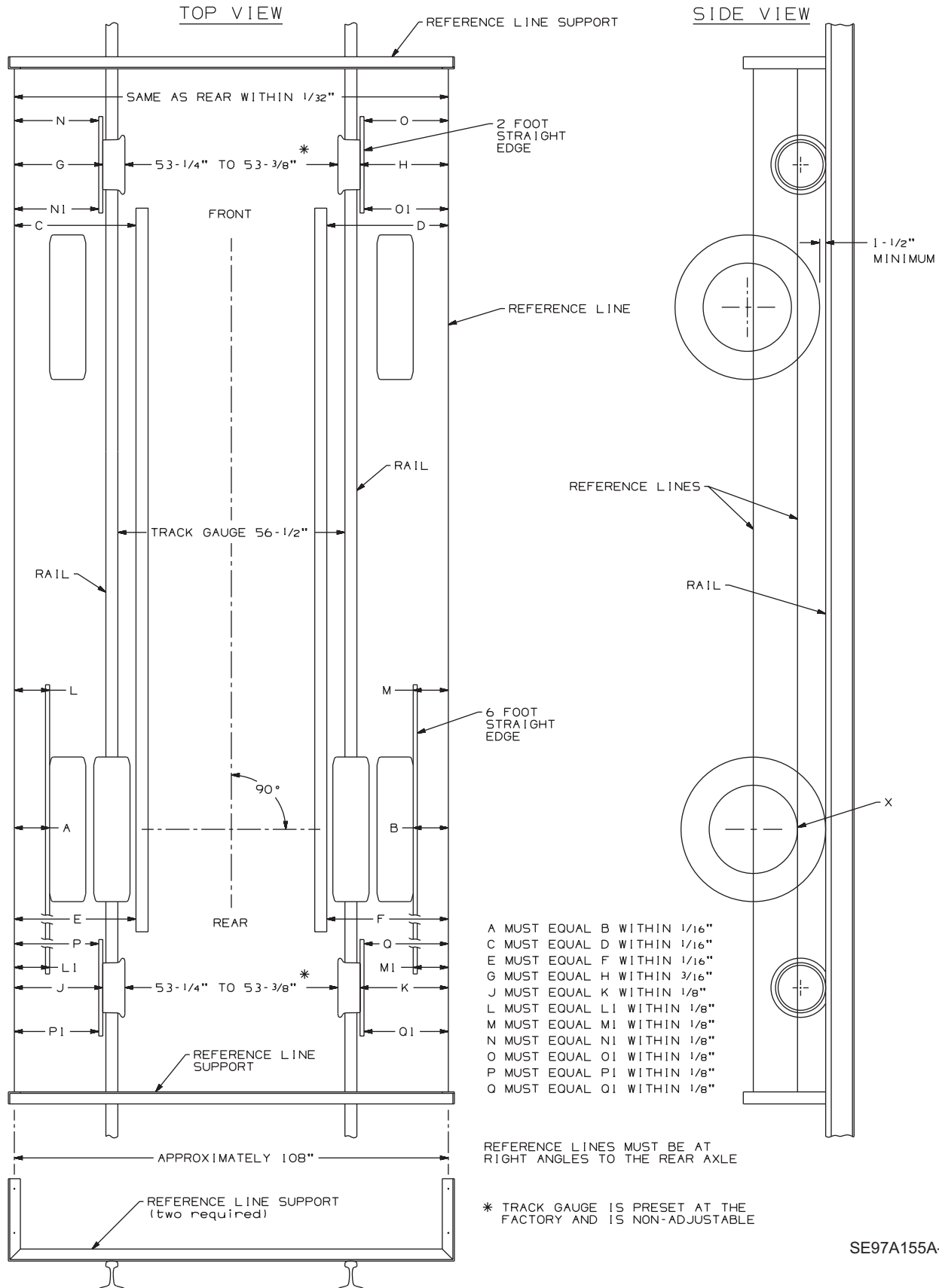

Guide Wheel Equipment Alignment Procedure

STRING LINING SET-UP - See Figure 3-2

1. The string lining procedure is only a guide to check and make alignment adjustments to the guide wheel equipment. String lining the vehicle and guide wheel equipment will not guarantee that the guide wheel equipped vehicle will track properly. Harsco Track Technologies recommends that all HY-RAIL® equipped vehicles be track tested. The vehicle should be at its normal operating load for track testing. The vehicle should be track tested when:
 - a. The guide wheel equipment is installed on the vehicle.
 - b. Any adjustments are made to the guide wheel equipment.
 - c. The load on the vehicle is changed.
 - d. Periodically to ensure that the vehicle is tracking properly.
2. Lower and lock the rear guide wheel unit in the "rail" position. Unlock and lower the front guide wheel unit. Do not completely lower and lock the front guide wheels in the "rail" position. Place the control valve handle in the ON RAIL (detent) position so that the guide wheels rest on the rail.
3. The front guide wheel unit may have up to 3/4 inch (19 mm) of side to side movement. It will be necessary to use a pry bar to move the front guide wheel axle from side to side to locate the center of this side to side movement. Prior to taking any measurements from the string lines to the front guide wheels, use the pry bar to position the front guide wheel axle at the center of its side to side movement.
4. Establish parallel reference lines on each side of the vehicle as shown in Figure 3-2. Parallel reference lines can be established by building two supports or brackets. These can be built out of scrap angle iron or other material. The supports must be high enough so the top reference line is through the center of the rear axle. The supports need to be a few inches longer than the width of the vehicle. Wires or cords stretched between the front and rear supports will be the reference lines. The wires or cords should be spaced approximately 108 inches (2.74 m) apart. The distance between the wires or cords must be equal or within 1/32 inch (.8 mm) at each support.
5. Clamp the supports to the rail in front of and behind the vehicle. The supports should be at right angles to the rail. Stretch the wires or cords between the supports, so the lower reference line is level with the bottom edge of the rear vehicle wheel rim(s) (point X) and the upper reference line is through the center of the rear axle(s). The reference lines must be level.

Guide Wheel Equipment Alignment Procedure

STRING LINING SET-UP - See Figure 3-2

3

6. Shift the supports on the rail until dimension A equals (=) B and dimension C equals (=) D or within 1/16 inch (1.6 mm). Measurements A and B should be taken from the edge of the rear vehicle rim(s) directly below the axle (point X) to the reference lines. Measurements C and D are taken from the front of the vehicle frame. When shifting the supports, keep them at right angles to the rail so the reference lines stay level and parallel to each other.
7. Hold a six (6) foot straight edge against the outer edge of the rear, outside tires with the straight edge centered on the tires. Record dimensions L, L1, M and M1 to the reference line. Rotate the rear tires 180 degrees and record a second set of dimensions at L, L1, M and M1. Average the two dimensions taken at L, L1, M and M1.

Example: [L (first dimension) + L (second dimension)] ÷ 2 = L (average dimension)

8. Shift the supports on the rail until dimension L (average) equals (=) M (average) and dimension L1 (average) equals (=) M1 (average) or within 1/8 inch (3.2 mm). When shifting the supports, keep them at right angles to the rail so the reference lines stay level and parallel to each other. The reference lines will be parallel only when the rear axle is straight.
9. After the reference lines have been established, measurements can be taken from these lines to the guide wheels to help ensure correct alignment.

Guide Wheel Equipment Alignment Procedure

FRONT GUIDE WHEEL ALIGNMENT

Checking Guide Wheel Alignment - See Figure 3-2

1. Ensure that the front guide wheels are centered in their side to side movement.
2. Take measurements G and H. Measure from the outer edge of the guide wheel, directly below the center line of the wheel spindle, to the reference lines. Check that dimension G equals (=) H or within 3/16 inch (4.8 mm). If not, see Adjustment.
3. The front guide wheels must track straight. Hold a two foot long straight edge against the outer edge of the front guide wheel. Take measurements N and N-1 and measurement O and O1. Check that dimension N equals (=) N1 and that dimension O equals (=) O1 or within 1/8 inch (3.2 mm). If not, see Adjustment.
4. *Note: The vehicle must be on level track.* The guide wheel unit's spring cell suspension tubes must be perpendicular (90 degrees) to the rail when the vehicle is in the "rail" position to permit proper operation of the suspension system. A bubble level placed against the front or rear of the spring cell suspension tube can be used to check this. If the spring cell suspension tubes are not perpendicular (90 degrees) to the rail, see Adjustment.
5. Any adjustments made to the guide wheel unit may affect the measurements and alignments checked in the above steps because of the necessity to loosen or remove the guide wheel unit mounting bolts. Always re-check the above measurements and alignments when any adjustments are made.

Guide Wheel Equipment Alignment Procedure

FRONT GUIDE WHEEL ALIGNMENT

Adjustment - See Figures 3-2 and 3-3

3

1. Move the control valve handle from the ON RAIL (detent) position to the neutral position. Let the guide wheels rest on the rails. Block or support the guide wheel unit.
2. To adjust the side to side alignment of the front guide wheel unit (dimensions G and H are equal or within 3/16 inch), remove the eight 3/4 inch cap screws (1) that secure the guide wheel unit to the frame or mounting brackets.
 - a. If dimension G is greater than dimension H, remove shim(s) (2) from between the frame or mounting bracket (3) and the mounting plate (4) on the right side of the guide wheel unit and install the shim(s) between the frame or mounting bracket (3) and the mounting plate (4) on the left side of the guide wheel unit.
 - b. If dimension H is greater than dimension G, remove shim(s) (2) from between the frame or mounting bracket (3) and the mounting plate (4) on the left side of the guide wheel unit and install the shim(s) between the frame or mounting bracket (3) and the mounting plate (4) on the right side of the guide wheel unit.
 - c. Install the eight 3/4 inch cap screws (1). Torque the cap screws to 375 ft lbs.
3. To adjust the tracking alignment of the front guide wheel unit, loosen the eight 3/4 inch cap screws (1). The holes in the guide wheel unit mounting plate (4) are slotted to allow forward or rearward adjustment of the unit. If necessary, use a reamer to enlarge the mounting holes to allow adjustment.
 - a. If dimension N is greater than N1 and dimension O is less than O1, move the left side of the guide wheel unit rearward or the right side of the guide wheel unit forward.
 - b. If dimension N is less than N1 and dimension O is greater than O1, move the left side of the guide wheel unit forward or the right side of the guide wheel unit rearward.
 - c. Torque the eight 3/4 inch cap screws (1) to 375 ft lbs.

Guide Wheel Equipment Alignment Procedure

FRONT GUIDE WHEEL ALIGNMENT

FIGURE 3-3
GUIDE WHEEL UNIT ALIGNMENT

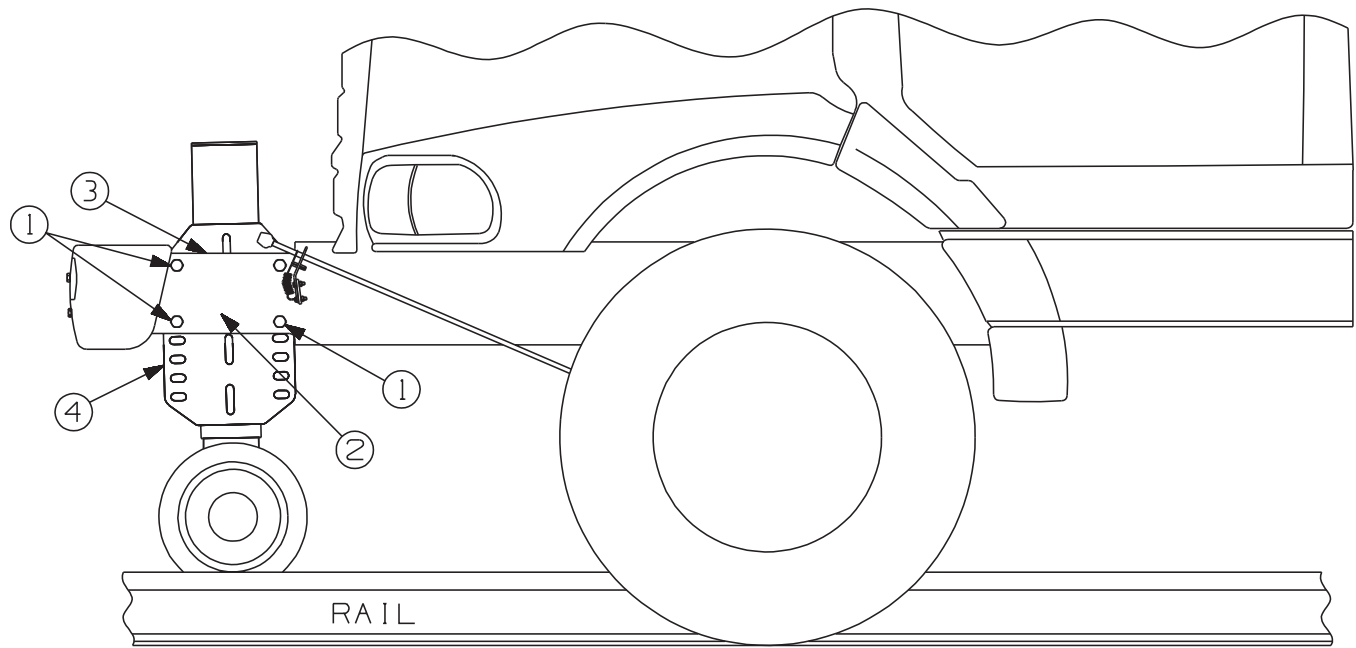

SE97A118A-1

Guide Wheel Equipment Alignment Procedure

FRONT GUIDE WHEEL ALIGNMENT

Adjustment - See Figures 3-3 and 3-4

3

4. *Note: The vehicle must be on level track.* To adjust the guide wheel unit's spring cell suspension tubes perpendicular (90 degrees) to the rail, loosen the eight 3/4 inch cap screws (1). The holes in the guide wheel unit mounting plate (4) are slotted to allow forward or rearward adjustment of the guide wheel unit. If necessary, use a reamer to enlarge the mounting holes to allow adjustment. Place a bubble level against the front or rear of the spring cell suspension tube.
 - a. Move the top or bottom of the guide wheel unit forward or rearward until the spring cell suspension tubes are perpendicular (90 degrees) to the rail.
 - b. Torque the eight 3/4 inch cap screws (1) to 375 ft lbs.
5. Repeat the measurements and alignments. Repeat any procedure(s) to help ensure proper alignment of the guide wheel equipment.

Guide Wheel Equipment Alignment Procedure

FRONT GUIDE WHEEL ALIGNMENT

FIGURE 3-4
GUIDE WHEEL EQUIPMENT ALIGNMENT

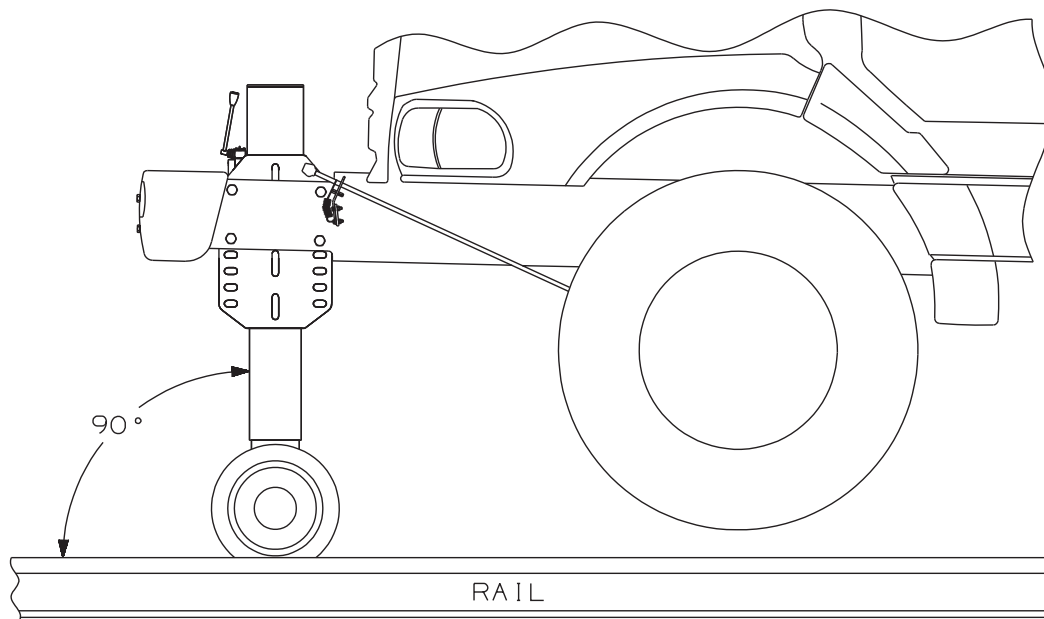

SE97A119A-1

Guide Wheel Equipment Alignment Procedure

VEHICLE TRACK TEST

3



■ **CHECK AND CORRECT ALIGNMENT PROMPTLY IF MISALIGNMENT IS INDICATED. MISALIGNMENT OF GUIDE WHEEL EQUIPMENT COULD RESULT IN DERAILMENT OF THE VEHICLE AND SEVERE BODILY INJURY.**

1. Harsco Track Technologies recommends that all HY-RAIL® equipped vehicles be track tested. The vehicle should be at its normal operating load for track testing. The vehicle should be track tested when:
 - a. The guide wheel equipment is installed on the vehicle.
 - b. Any adjustments are made to the guide wheel equipment.
 - c. The load on the vehicle is changed.
 - d. Periodically to ensure that the vehicle is tracking properly.
2. The vehicle must be placed on straight, level, tangent track. See Operation Section - Placing Vehicle On Track.
3. Apply spray paint to the flanges and treads of all guide wheels.
4. Lower and lock both guide wheel units in the "rail" position.
5. Operate the vehicle for a short distance at a normal operating speed.
6. The paint should wear evenly around the flanges and treads of all guide wheels. If the paint is worn evenly on all guide wheels, the vehicle and guide wheel equipment is properly aligned.
7. If the paint wore off the right front guide wheel flange and not off the left front guide wheel flange, the guide wheel unit is "flanging right".
 - a. Unlock and lower the front of the vehicle from the "rail" position. Let the guide wheels rest on the rail. Place the control valve handle in the "neutral" position. Support the guide wheel unit. Loosen the mounting bolts and slightly move the right side of the guide wheel unit forward or the left side of the guide wheel unit slightly rearward. Torque the mounting bolts to 375 ft lbs.
 - b. Repaint the flanges and treads on all guide wheels. Lower and lock the guide wheel unit in the "rail" Position. Operate the vehicle for a short distance at a normal operating speed. If the paint is worn evenly on all guide wheels, the vehicle and guide wheel equipment is properly aligned.
 - c. If the paint continues to wear off the right front guide wheel flange and not off the left front guide wheel flange, repeat Steps a. & b. If the guide wheel unit is adjusted to the limit of the mounting hole slots, go to Step 9.

Guide Wheel Equipment Alignment Procedure

VEHICLE TRACK TEST

8. If the paint wore off the left front guide wheel flange and not off the right front guide wheel flange, the guide wheel unit is "flanging left".
 - a. Unlock and lower the front of the vehicle from the "rail" position. Let the guide wheels rest on the rail. Place the control valve handle in the "neutral" position. Support the guide wheel unit. Loosen the mounting bolts and slightly move the left side of the guide wheel unit forward or the right side of the guide wheel unit slightly rearward. Torque the mounting bolts to 375 ft lbs.
 - b. Repaint the flanges and treads on all guide wheels. Lower and lock the guide wheels in the "rail" Position. Operate the vehicle for a short distance at a normal operating speed. If the paint is worn evenly on all guide wheels, the vehicle and guide wheel equipment is properly aligned.
 - c. If the paint continues to wear off the left front guide wheel flange and not off the right front guide wheel flange, repeat Steps a. & b. If the guide wheel unit is adjusted to the limit of the mounting hole slots, go to Step 9.
9. Note which guide wheels, flange and/or tread the paint is worn on.
 - a. Repaint the flanges and treads on all guide wheels.
 - b. Operate the vehicle in reverse for a short distance at a normal operating speed.
 - c. Note which guide wheels, flange and/or tread the paint is worn on.

If the paint wore off the right front flange when traveling forward and then off the left rear flange when traveling in reverse or off the left front flange when traveling forward and then off the right rear flange when traveling in reverse, the vehicle is probably not aligned properly. Have the frame checked for proper alignment. See Vehicle Check.
10. If the vehicle continues to track improperly, repeat the String Lining and Guide Wheel Alignment Procedure.

Adjustments

VEHICLE FRONT TIRE CLEARANCE - RAIL POSITION

The vehicle's front tire clearance should be checked whenever the vehicle is placed on rail or whenever the load on the vehicle is changed significantly.

3

Checking Vehicle Front Tire Clearance - Rail Position - See Figure 3-5

1. Place the vehicle on straight, level, tangent track. Place the vehicle automatic transmission in "Park" or manual transmission in "Neutral". Apply the parking brake. Lower and lock both guide wheel units in the "rail" position. See Operation Section - Placing Vehicle On Track.
2. When the front guide wheels are lowered and locked in the "rail" position, the axle hooks will raise the vehicle's front tires above the rails. This is necessary to ensure clearance when the vehicle passes through switches, turnouts, crossings, frogs, etc. As the vehicle is loaded, the front tire clearance will decrease. The front tires must always clear the top of the rails by a minimum of 1-1/2 inches (38 mm) whenever the vehicle is on track. If not, see Adjustment.

Adjustment - See Figure 3-5

1. Unlock and raise the front guide wheels to lower the front of the vehicle to the ground. Loosen and remove the two flange nuts and cap screws (1). Reposition the lower part (2) of the two piece axle hook to a different pair of holes in the upper part (3) of the hook assembly. Reinstall and tighten the two flange nuts and cap screws (1). Repeat this procedure to adjust the other axle hook. Both axle hooks must be adjusted to maintain the minimum vehicle front tire to rail clearance for both front tires.
2. Lower and lock the front guide wheels in the "rail" position. Recheck the vehicle front tire clearance. If necessary, repeat the adjustment procedure until the minimum of 1-1/2 inches (38 mm) of clearance is obtained.
3. If the front axle hooks cannot be adjusted to obtain the 1-1/2 inch (38 mm) minimum clearance, the guide wheel unit must be repositioned in a different set of mounting holes or different axle hooks must be applied to the vehicle. For axle hook replacement, contact Harsco Track Technologies, Harsco Corporation, Fairmont, Minnesota.

Adjustments

VEHICLE FRONT TIRE CLEARANCE - RAIL POSITION

FIGURE 3-5
VEHICLE FRONT TIRE CLEARANCE

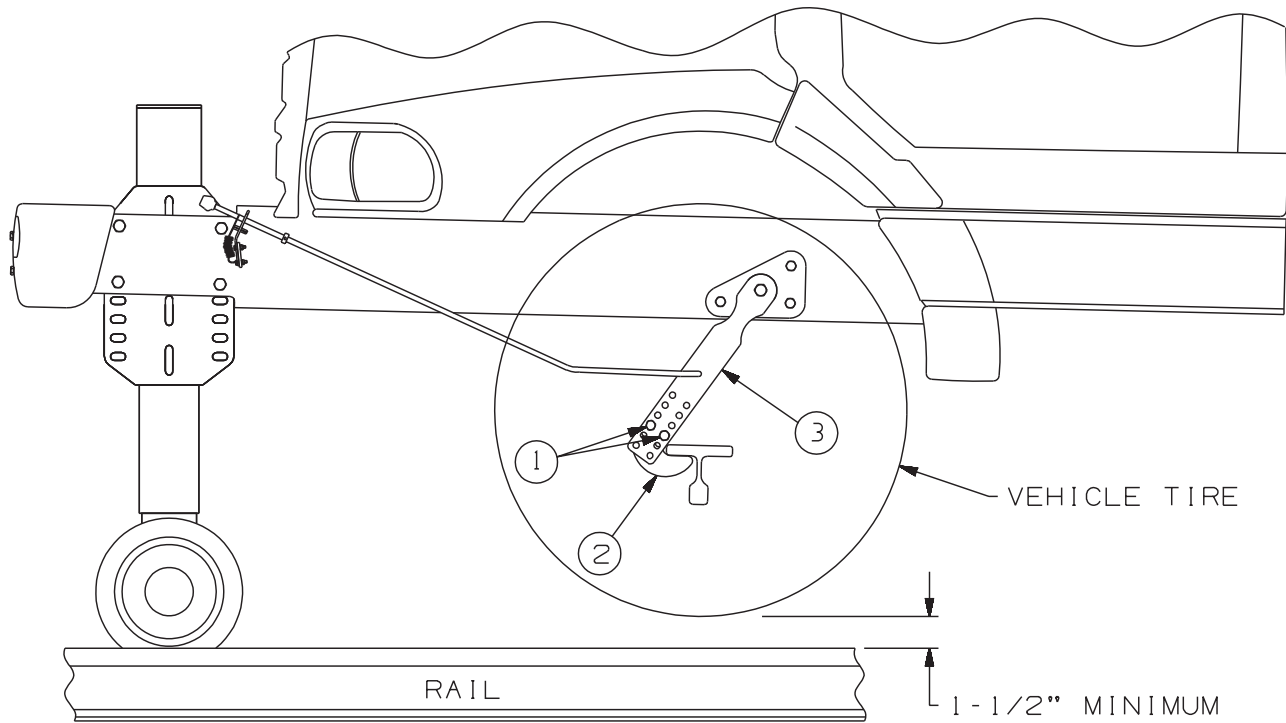

Adjustments

AXLE HOOK CLEARANCE - HIGHWAY POSITION

The axle hook clearance should be checked whenever adjustments are made to the guide wheel unit or whenever the load on the vehicle is changed significantly.

3

Park the vehicle on solid level ground. The vehicle must be loaded with its normal operating load. Place the vehicle automatic transmission in "Park" or manual transmission in "Neutral". Apply the parking brake. Stop the engine.

Note: On some vehicle applications the axle hooks may be reversed and will engage under the axle from the rear instead of from the front as illustrated. This will cause the axle hook control rod to engage and disengage the axle hooks in the opposite direction.

Checking Axle Hook Clearance - Highway Position - See Figure 3-6

1. Measure the distance from the "toe" of both axle hooks (1) to the axle (2). The minimum clearance between the axle hook "toe" and the axle is 3/4 inch (19 mm).
2. Both axle hooks must be adjusted to obtain equal clearance from the axle. If the axle hook clearance is incorrect, see Adjustment.

Adjustment - See Figure 3-6

1. To adjust the axle hooks, position the axle hook control rod (3) so the axle hook is at least 3/4 inch (19 mm) away from the axle. Loosen set screw (4) on collar (5). Slide collar (5) tight against plate (6). Tighten set screw (4).
2. Repeat this procedure to adjust the axle hook clearance for the other axle hook.

Adjustments

AXLE HOOK CLEARANCE - HIGHWAY POSITION

FIGURE 3-6
AXLE HOOK CLEARANCE

3

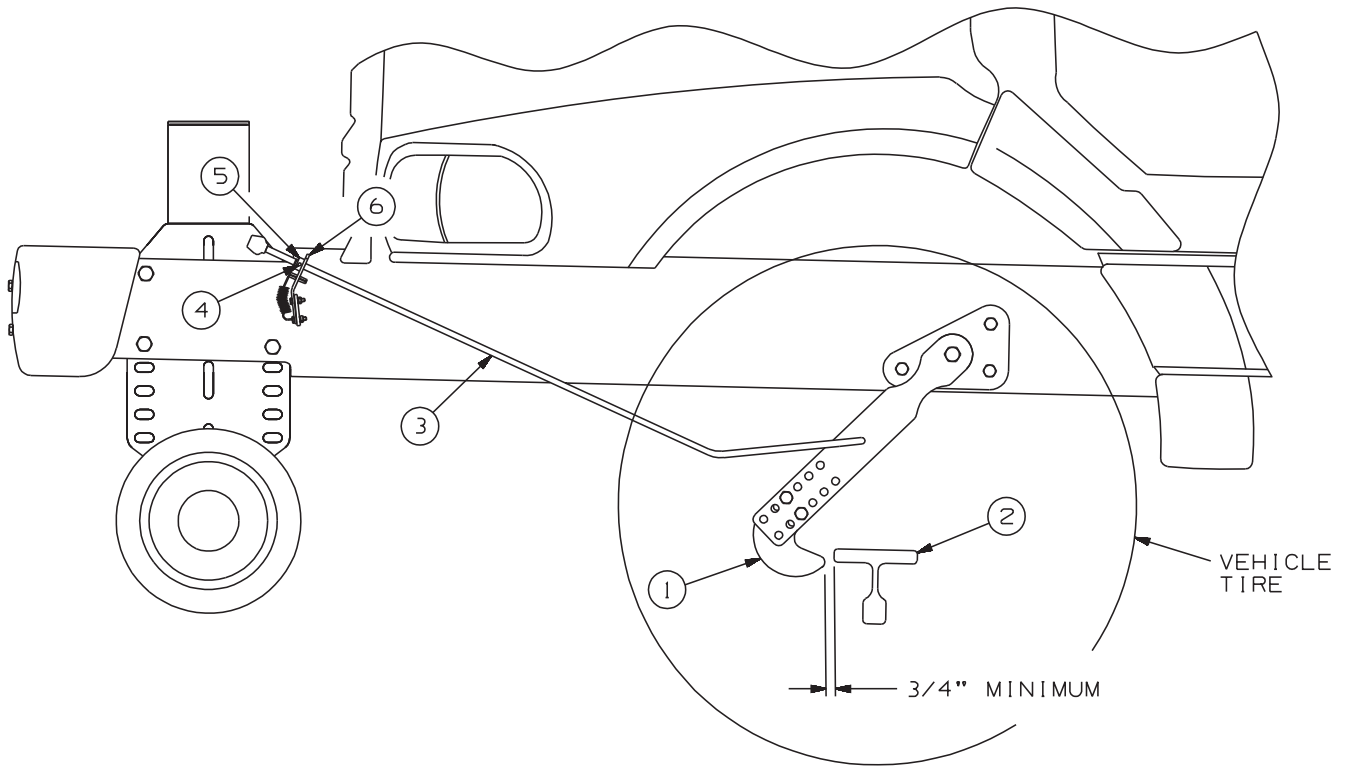

SE97A121A-1

Adjustments

BRAKE SHOE CLEARANCE

Checking Brake Shoe Clearance - See Figure 3-7

3

1. Apply the parking brakes. Be sure the vehicle air brake system is at operating pressure to fully release the guide wheel brakes. Move the rail wheel brake control valve to the On position.
2. Measure the clearance between the brake shoe and the guide wheel tread. The clearance must not exceed 1/8 inch (3.2 mm), or adjustment is required. See Adjustment.
3. Repeat Step 2 to check the brake shoe clearance on the other guide wheel brake.

Adjustment - See Figure 3-7

1. Remove the cotter pin from the pin (1). Remove the pin (1) from the yoke (2) on the brake actuator (3). Loosen jam nut (4) and turn yoke (2) counter-clockwise to adjust the brake shoe closer to the guide wheel tread or clockwise to adjust the brake shoe away from the guide wheel tread.
2. Adjust so the brake shoe is 1/32 - 1/16 inch (.8 - 1.6 mm) away from the guide wheel tread. Install the pin (1) through the yoke (2) and brake arm (5) and secure using the cotter pin. Tighten jam nut (4) securely. Recheck the brake shoe clearance.
3. Repeat this procedure to adjust the brake shoe clearance on the other guide wheel brake.

Adjustments

BRAKE SHOE CLEARANCE

FIGURE 3-7
BRAKE SHOE CLEARANCE

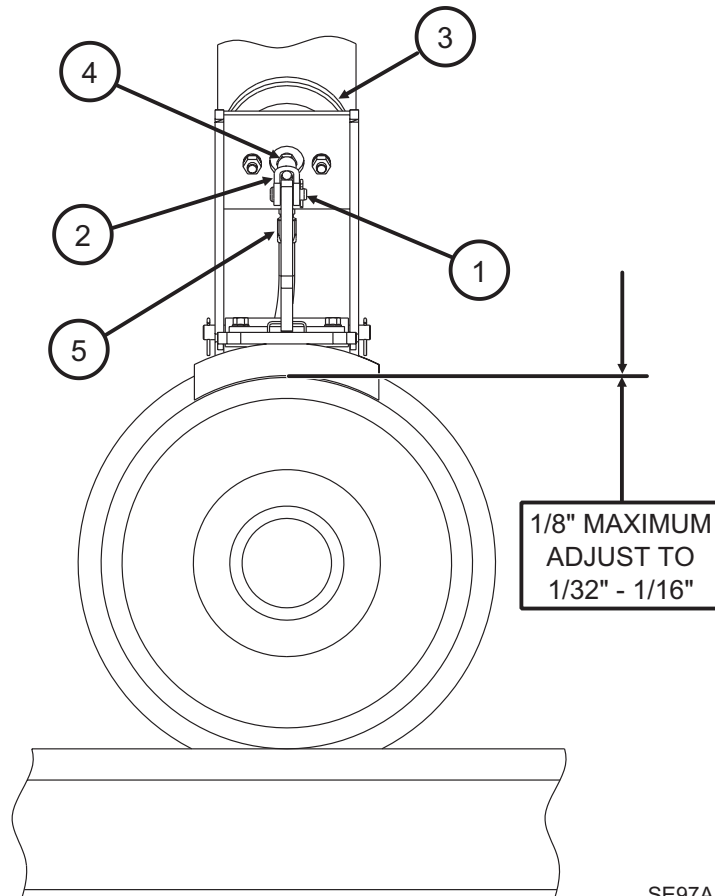

SE97A156A-1

Adjustments

RAIL SWEEP GROUP - SWEEP CLEARANCE

Checking Rail Sweep Clearance - See Figure 3-8

3 The front guide wheel unit may be equipped with rail sweeps.

1. Place the vehicle on straight, level track. Place the vehicle automatic transmission in "Park" or manual transmission in "Neutral". Apply the vehicle parking / emergency brake. Lower and lock the front and rear guide wheels in the "rail" position.
2. The rubber rail sweeps should clear the top of the rail by 3/16 inch (4.8 mm). If not, see Adjustment.

Adjustment - See Figure 3-8

1. Loosen the two hex nuts (1) on cap screws (2). Slide the rubber sweep (3) down until it clears the top of the rail by 3/16 inch (4.8 mm). Re-tighten the two hex nuts (1) and cap screws (2).
2. Repeat this procedure to adjust the rail sweep clearance on the other guide wheel.
3. When the rubber sweep is worn so it cannot be adjusted, replace the rubber sweep (3).

FIGURE 3-8
RAIL SWEEP CLEARANCE

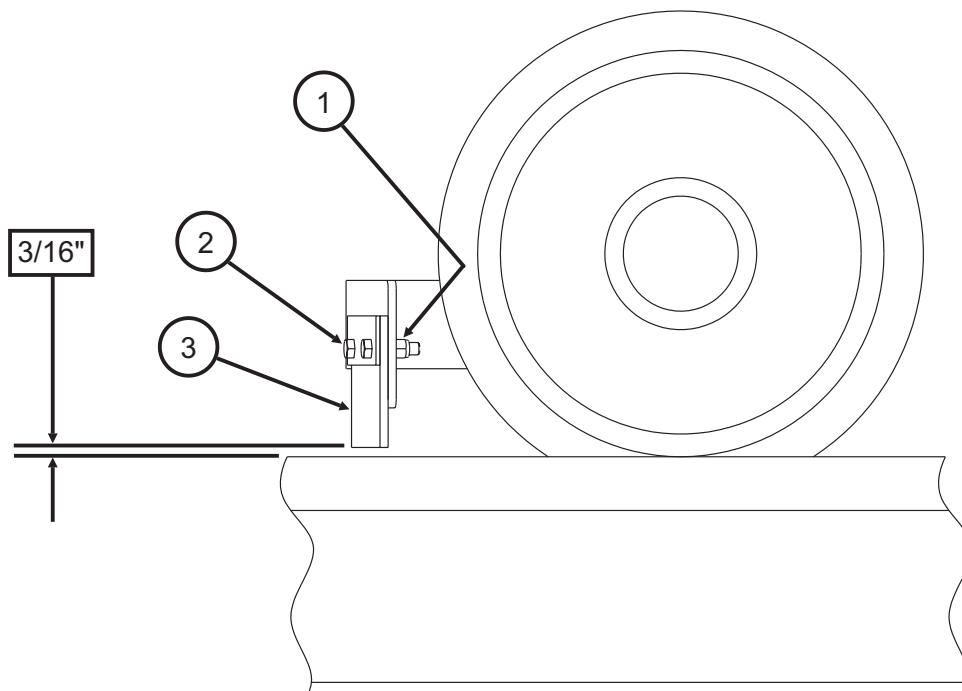

SE97A122A-1

**SECTION 4 - MAINTENANCE
TABLE OF CONTENTS**

Maintenance Schedule

MAINTENANCE SCHEDULE..... 4 - 2

Waste Disposal

WASTE DISPOSAL 4 - 3

Guide Wheel Equipment Lubrication

FRONT GUIDE WHEEL UNIT LUBRICATION 4 - 4
RE-PACKING GUIDE WHEEL BEARINGS 4 - 6

Guide Wheels

ALLOWABLE WEAR 4 - 7

Hoses And Fittings

INSPECTION, MAINTENANCE, REPLACEMENT AND INSTALLATION 4 - 8
HOSE BAND 4 - 8

Vehicle Wheels

WHEEL REPLACEMENT..... 4 - 9
TIRE REPLACEMENT 4 - 9

Bolt Torque Requirements

BOLT TORQUE REQUIREMENTS 4 - 9

Maintenance Schedule



- **RE-TORQUE VEHICLE WHEEL LUG NUTS AND GUIDE WHEEL LUG NUTS AFTER THE FIRST 50 MILES OF OPERATION. THEREAFTER TORQUE WHEEL LUG NUTS ACCORDING TO VEHICLE MANUFACTURER'S WHEEL TORQUE SPECIFICATIONS. FAILURE TO COMPLY COULD RESULT IN SEVERE BODILY INJURY.**

DAILY:

1. Inspect the front and rear guide wheel units for damaged, worn or missing parts.
2. Check the mechanical locks and lock pins for ease of operation.
3. Check the hydraulic reservoir to ensure that the oil level is full. If low, fill to the proper level with the correct fluid.
4. When the vehicle is operated on the track, listen for unusual noises. Unusual noises may indicate incorrectly lowered guide wheels, damaged or missing parts, or insufficient lubrication. Pay attention to the quality of the ride. Check the guide wheel equipment alignment if the vehicle crowds one side of the track instead of floating from side to side. See Adjustments - Guide Wheel Equipment Alignment Procedure.

4

WEEKLY:

1. Check the guide wheel equipment alignment. See Adjustment Section, Guide Wheel Equipment Alignment Procedure - Vehicle Track Test.
2. Inspect the guide wheel tread and flanges for wear or damage. See Maintenance - Guide Wheel Allowable Wear.
3. Spin each guide wheel by hand, checking for ease of rotation. If the guide wheel does not rotate easily, the guide wheel bearings may be lacking lubrication or may be damaged. Inspect, re-pack or replace the bearings if necessary.
4. Inspect the vehicle wheels, studs, lug nuts and tires for wear, damage, cuts etc.
5. Check the vehicle tires for correct inflation pressure. Operate at the tire manufacturer's recommended maximum pressure printed on the sidewalls of the tires, or the wheel manufacturer's recommended maximum pressure stamped on the wheel, whichever is lower.
6. Check all bolts for tightness. See Appendices - Appendix A, Bolt Torque Requirement Chart.

Maintenance Schedule

At 50 Vehicle Miles (80 Vehicle km):

Torque the vehicle wheel lug nuts and guide wheel lug nuts to the recommended specifications. Thereafter refer to the vehicle manufacturer's wheel torque specifications.

Every 2,000 Track Miles (3200 km):

Lubricate the guide wheel unit locations provided with grease fittings. See Guide Wheel Equipment Lubrication.

At 10,000 Track Miles (16000 km):

Re-pack and adjust the guide wheel bearings. See Re-packing Guide Wheel Bearings.

Waste Disposal

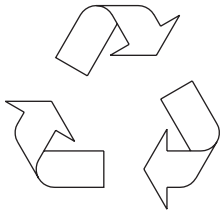

Dispose of waste properly. Improper disposal of waste can threaten the environment. The operation and maintenance of Harsco Track Technologies equipment may involve the use of such items as hydraulic oil, engine oil, fuel, coolant, brake fluid, filters, batteries, etc.

Use leak proof containers when draining fluids. Do not pour waste onto the ground, down a drain, or into any water source. Inquire on the proper way to recycle or dispose of waste according to applicable Federal, State and/or local regulations.

Guide Wheel Equipment Lubrication

Lubricate the guide wheel equipment every 2000 track miles (maximum) or each time the vehicle is serviced.

FRONT GUIDE WHEEL UNIT LUBRICATION - See Figure 4-1

1. Apply the vehicle parking brake. Stop the vehicle engine. Turn the vehicle's ignition switch off.
2. Lubricate grease fittings (A) using Mobil Special Moly, or equivalent.
3. Re-pack the guide wheel bearings (B) every 10,000 track miles (maximum) or at least once every two years (minimum), whichever occurs first. See Re-packing Guide Wheel Bearings.

Guide Wheel Equipment Lubrication

FIGURE 4-1
FRONT GUIDE WHEEL UNIT LUBRICATION

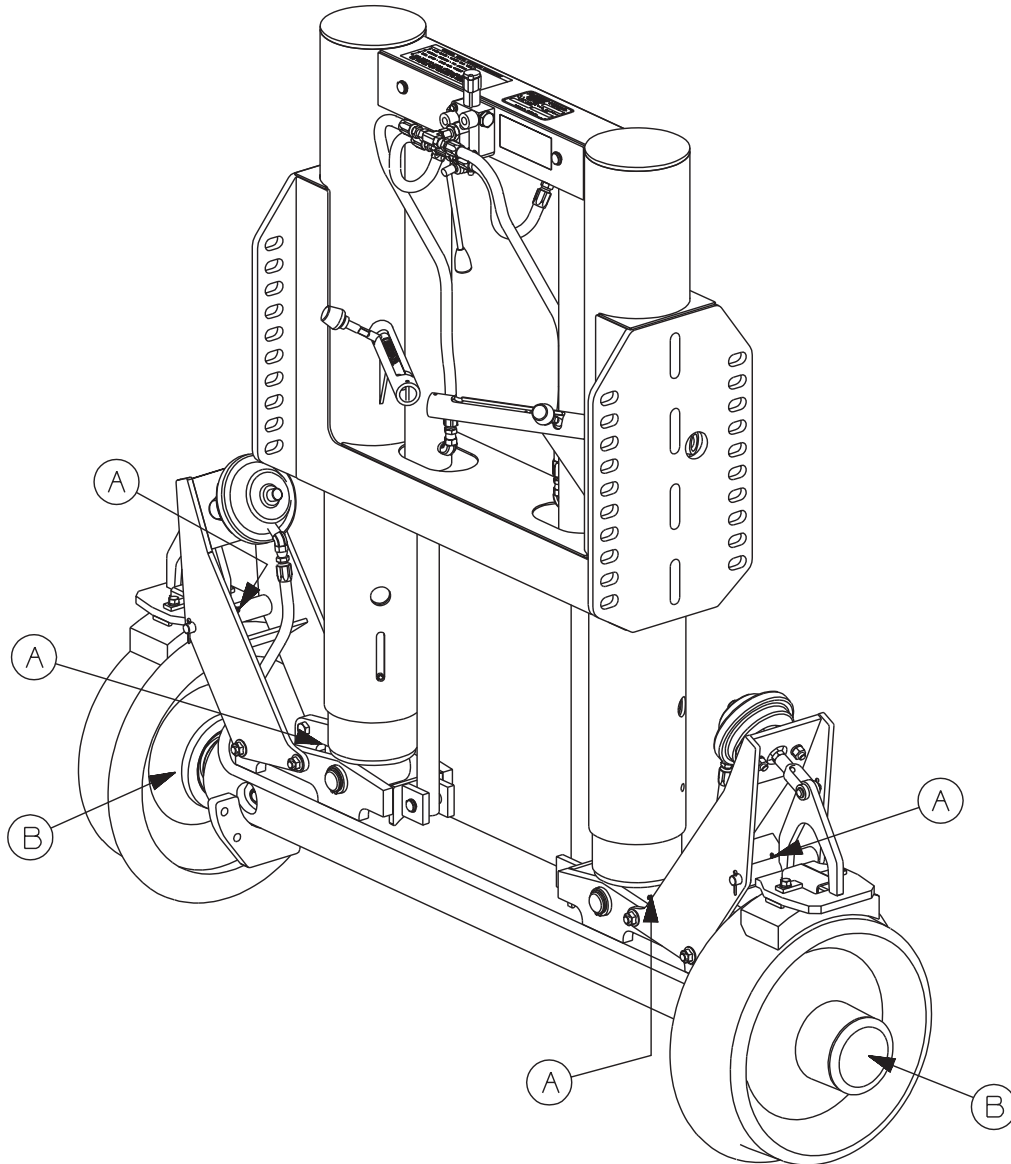

Guide Wheel Equipment Lubrication

RE-PACKING GUIDE WHEEL BEARINGS - See Figure 4-2

Re-pack the guide wheel bearings every 10,000 track miles (maximum) or at least once every two years (minimum), whichever occurs first.

1. Apply the parking brake. Raise and lock the front and rear guide wheel units in the "highway" position. Stop the vehicle engine. Shut off the vehicle ignition switch.
2. Remove the hub cap (1). Remove the 3/16 x 2-1/2 inch cotter pin (2), 1-1/2 inch castle nut (3) and spindle washer (4).
3. Pull the guide wheel (5) from the spindle (6). Remove the outer bearing cone (7) from the guide wheel (5). Remove the grease seal (11) and inner bearing cone (9) from the guide wheel (5).
4. Clean all components of old grease and dirt.
5. Inspect the spindle, bearing cones and cups (7 & 8, 9 & 10) for nicks, gouges and wear. If any of these are evident, replace the component.
6. Measure the guide wheel wear. See Maintenance - Guide Wheels, Allowable Wear.
7. Coat the spindle surface, grease seal surface, both bearing cup surfaces, pack both bearing cones and fill the guide wheel cavity 1/2 full (50 %) using Mobil HP grease, or equivalent.
8. Install the inner bearing cone (9) into the guide wheel (5). Install a new grease seal (11) into the wheel.
9. Slide the guide wheel (5) with the inner bearing (9) and grease seal (11) onto the spindle (6). Install the outer bearing cone (7), spindle washer (4) and 1-1/2 inch castle nut (3) onto the spindle (6).
10. Torque the castle nut (3) to approximately 20 ft lbs. Then loosen the castle nut. This is especially important if new bearing cups have been installed.
11. Torque the castle nut (3) to 7 ft lbs (zero clearance). Then back the castle nut off 1/2 to 1 flat of the nut (.001 - .010 inch clearance). Secure the castle nut using a new cotter pin (2).
12. Install the hub cap (1) onto the guide wheel.

FIGURE 4-2
RE-PACKING GUIDE WHEEL
BEARINGS

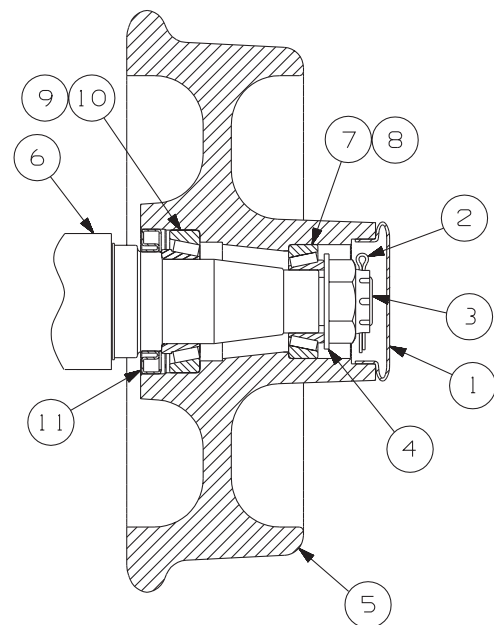

Guide Wheels

ALLOWABLE WEAR - See Figure 4-3



■ **REPLACE ANY GUIDE WHEEL IMMEDIATELY WHICH SHOWS DAMAGE AND/OR HAS WORN MORE THAN THE ALLOWABLE LIMITS. FAILURE TO COMPLY COULD RESULT IN DERAILMENT OF THE VEHICLE, AND SEVERE BODILY INJURY.**

1. Tools needed: Harsco Track Technologies wheel caliper (M019889), or equivalent.
2. Measure the guide wheel flange at Position "A" with the wheel caliper. The minimum allowable flange dimension at Position "A" is 7/8 inch (22.2 mm).

If the guide wheel flange dimension is less than the allowable limit, replace the guide wheel immediately.

3. Measure the guide wheel tread at Position "B" with the wheel caliper. The minimum allowable tread dimension at Position "B" is 1/2 inch (12.7 mm).

If the guide wheel tread dimension is less than the allowable limit, replace the guide wheel immediately.

4. The entire guide wheel must not have any gouges or cracks. If any of these are evident, replace the guide wheel immediately.

FIGURE 4-3
ALLOWABLE GUIDE WHEEL WEAR

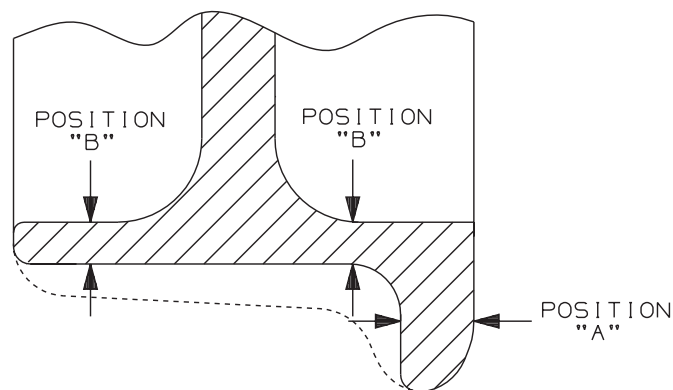

SE93A124A-1

Hoses and Fittings



- ALL HOSES AND FITTINGS ON THIS EQUIPMENT MUST COMPLY WITH SAE STANDARD J1273 RECOMMENDED PRACTICE FOR SELECTION, INSTALLATION AND MAINTENANCE OF HOSE AND HOSE ASSEMBLIES. FAILURE TO COMPLY TO THIS STANDARD COULD RESULT IN SEVERE BODILY INJURY.

INSPECTION, MAINTENANCE, REPLACEMENT AND INSTALLATION

The inspection, maintenance, replacement and installation of hydraulic hose assemblies and fittings on this equipment must conform with SAE Standard J1273. See Appendices Section - Appendix B.

HOSE BAND - See Figure 4-4

4

All Harsco Track Technologies original and replacement hose assemblies manufactured for this equipment at the Harsco Track Technologies, Harsco Corporation Fairmont, Minnesota plant facility are supplied with a hose band displaying the date of manufacture and the Harsco Track Technologies part number. See Figure 4-4 for explanation of the hose band. The hose assembly illustrated in the example was manufactured in February 2001 and is Harsco Track Technologies part number 188662.

FIGURE 4-4
HOSE BAND

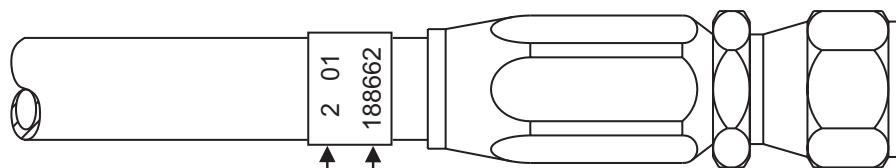

2	01	
MONTH	YEAR	
JANUARY = 1	LAST TWO DIGITS	
FEBRUARY = 2	OF THE YEAR OF	
MARCH = 3	MANUFACTURE	
APRIL = 4		
MAY = 5		
JUNE = 6		
JULY = 7		
AUGUST = 8		
SEPTEMBER = 9		
OCTOBER = 0		
NOVEMBER = N		
DECEMBER = D		

188662
HARSCO TRACK
TECHNOLOGIES
PART NUMBER

Vehicle Wheels

WHEEL REPLACEMENT



- **USE REPLACEMENT WHEELS AS RECOMMENDED IN THE HARSCO TRACK TECHNOLOGIES HY-RAIL® VEHICLE SPECIFICATIONS MANUAL. FAILURE TO COMPLY COULD RESULT IN BODILY INJURY AND/OR PROPERTY DAMAGE.**

Use replacement wheel rim(s) as recommended in the Harsco Track Technologies HY-RAIL® Vehicle Specifications Manual to ensure correct vehicle wheel spacing and accurate guide wheel load. The wheels and tires should be static balanced or balanced after installation on the vehicle for best results. Torque vehicle wheel lug nuts to recommended specifications.

TIRE REPLACEMENT



- **USE REPLACEMENT TIRES WITH THE SAME ROLLING RADIUS, TREAD WIDTH, PLY RATING, AND LOAD RATING AS RECOMMENDED IN THE HARSCO TRACK TECHNOLOGIES HY-RAIL® VEHICLE SPECIFICATIONS MANUAL. FAILURE TO COMPLY COULD RESULT IN BODILY INJURY AND/OR PROPERTY DAMAGE.**

4

Bias ply tires are the recommended tire for use on vehicles equipped with guide wheel equipment. Radial tires may influence vehicle tracking. Performance of vehicles equipped with radial tires is the responsibility of the end user.

Replacement tires must have the same rolling radius, tread width, ply rating, and load rating as recommended in the Harsco Track Technologies HY-RAIL® Vehicle Specifications Manual. Using tires of equal diameter will help keep the speedometer reading and the guide wheel load accurate. Tires must have a minimum 6-1/2 inches of tread width.

Inflate tires to the tire manufacturer's recommended maximum pressure printed on the sidewall of the tire or to the wheel manufacturer's recommended maximum pressure stamped on the wheel, whichever is lower. The wheels and tires should be static balanced or balanced after installation on the vehicle for best results. Torque vehicle wheel lug nuts to recommended specifications.

Bolt Torque Requirements



- **CHECK ALL BOLTS AND NUTS PERIODICALLY. KEEP BOLTS AND NUTS TIGHTENED TO THE TORQUE SPECIFIED IN APPENDICES SECTION - APPENDIX A. IF BOLT REPLACEMENT BECOMES NECESSARY, REPLACE WORN BOLT WITH EQUAL S.A.E. GRADE NUMBER BOLT. FAILURE TO COMPLY COULD RESULT IN BODILY INJURY, AND/OR PROPERTY DAMAGE.**

See Appendices Section - Appendix A, for bolt torque requirements table and grade identification markings used by manufacturers.

**SECTION 5 - TROUBLESHOOTING
TABLE OF CONTENTS**

Troubleshooting Guide Wheel Equipment

TROUBLESHOOTING CHART 5 - 2

Troubleshooting Guide Wheel Equipment

5

PROBLEM	PROBABLE CAUSE	POSSIBLE REMEDY
<p>Hydraulic pump not delivering oil.</p>	<p>Mechanical PTO not engaged or control valve not shifted to direct oil flow to guide wheel equipment.</p> <p>Switch for auxiliary electric powered hydraulic pump in OFF position.</p> <p>Hydraulic reservoir oil level low.</p> <p>Oil restricted to pump intake.</p> <p>Components bent, broken, worn, etc.</p>	<p>Engage mechanical PTO. Shift control valve to direct oil flow to guide wheel equipment.</p> <p>Move switch to ON position.</p> <p>Fill reservoir to full level with recommended hydraulic oil.</p> <p>Check all strainers and filters for dirt and sludge. Clean and replace if necessary.</p> <p>Replace components.</p>
<p>Guide wheel unit does not lower or raise.</p>	<p>Lock pins installed.</p> <p>Hydraulic pump not operating.</p> <p>Hydraulic reservoir oil level low.</p> <p>Components bent, broken, worn, etc.</p>	<p>Remove lock pins. See Operation Section - Placing Vehicle On Track or Removing Vehicle From Track.</p> <p>Start hydraulic pump.</p> <p>Fill reservoir to full level with recommended hydraulic oil.</p> <p>Replace components.</p>
<p>Guide wheel unit is difficult to lower or raise.</p>	<p>Vehicle over-loaded.</p> <p>Components bent, broken, worn, etc.</p>	<p>Remove excess load from vehicle.</p> <p>Replace components.</p>
<p>Lock pins cannot be inserted when guide wheel unit is in "rail" or "highway" position.</p>	<p>Components bent, broken, worn, etc.</p>	<p>Replace components.</p>

Troubleshooting Guide Wheel Equipment

PROBLEM	PROBABLE CAUSE	POSSIBLE REMEDY
<p>Vehicle front tires clear rail less than 1-1/2" (38 mm) when vehicle is on track and loaded.</p>	<p>Vehicle overloaded.</p> <p>Axle Hooks not lifting front axle high enough.</p> <p>Front guide wheel unit not positioned in proper holes of mounting brackets.</p>	<p>Redistribute or remove some of the load.</p> <p>See Adjustment Section - Vehicle Front Tire Clearance - Rail Position.</p> <p>Mount front guide wheel unit in correct mounting holes. See application drawings supplied with guide wheel equipment group.</p>
<p>Vehicle derails.</p>	<p>Guide wheel units, vehicle rear axle, etc. not aligned with vehicle frame.</p>	<p>Check alignment. See Adjustment Section - Guide Wheel Equipment Alignment Procedure.</p>
<p>Vehicle pulls noticeably to the left or right when on track.</p>	<p>Vehicle loaded heavy on one side.</p> <p>Guide wheel units, vehicle rear axle, etc. not aligned with vehicle frame.</p> <p>Incorrect or worn vehicle rear tire.</p> <p>Vehicle rear tires under inflated.</p> <p>Guide wheel brake shoes dragging.</p>	<p>Move load to center of vehicle.</p> <p>Check alignment. See Adjustment Section - Guide Wheel Equipment Alignment Procedure.</p> <p>Check for correct rear tire. Replace if necessary. Replace worn rear tire.</p> <p>Check pressure. Inflate if low.</p> <p>Do not exceed tire manufacturer's recommended maximum pressure printed on the sidewalls, or wheel manufacturer's recommended maximum pressure stamped on the wheel, whichever is lower.</p> <p>Re-adjust brake shoes. See Adjustment Section - Brake Shoe Clearance</p>

Troubleshooting Guide Wheel Equipment

5

PROBLEM	PROBABLE CAUSE	POSSIBLE REMEDY
Vibration felt in the vehicle when traveling on track.	<p>Guide wheel units mounting fasteners loose.</p> <p>Guide wheel bearings worn.</p> <p>Guide wheels worn.</p> <p>Vehicle rear rim bent.</p> <p>Vehicle rear tires out of balance.</p>	<p>Tighten all bolts to recommended torque.</p> <p>Replace bearings, wheel or axle.</p> <p>Check guide wheel wear. See Maintenance Section - Guide Wheels, Allowable Wear.</p> <p>Replace. See Parts Section - Vehicle Applications.</p> <p>Balance tires.</p>
Vehicle load on front spring cells exceeds front Guide wheel unit maximum rated load.	Vehicle overloaded.	Redistribute or remove some of the load.
Vibration felt in the vehicle when traveling on highway.	<p>Guide wheel units mounting fasteners loose.</p> <p>Guide wheel units not locked in "highway" position.</p> <p>Vehicle rim bent.</p> <p>Vehicle tires out of balance.</p>	<p>Tighten all bolts to recommended torque.</p> <p>STOP IMMEDIATELY. Make sure both guide wheel units are locked in "highway" position.</p> <p>Replace. See Parts Section - Vehicle Applications.</p> <p>Balance tires.</p>

**SECTION 6 - APPENDICES
TABLE OF CONTENTS**

Appendix A - Conversion Tables

BOLT TORQUE REQUIREMENTS - STANDARD TYPE FASTENERS 6 - 2
BOLT TORQUE REQUIREMENTS - SERRATED TYPE FLANGE FASTENERS . . . 6 - 3
BOLT TORQUE REQUIREMENTS - METRIC TYPE FASTENERS 6 - 4
INCH TO MILLIMETERS 6 - 6
FEET TO METERS 6 - 6
POUNDS TO KILOGRAMS 6 - 7
POUNDS PER SQUARE INCH TO BAR 6 - 7
POUNDS PER SQUARE INCH TO KILOPASCALS 6 - 7
FAHRENHEIT TO CELSIUS (Centigrade). 6 - 8
MILES PER HOUR TO KILOMETERS PER HOUR 6 - 9
GALLONS TO LITERS. 6 - 9

Appendix B - SAE J1273

SAE J1273 - NOVEMBER 1991
SELECTION, INSTALLATION AND MAINTENANCE
OF HOSE AND HOSE ASSEMBLIES 6 - 10

Appendix A

**FIGURE 6-1
STANDARD BOLT TORQUE REQUIREMENTS TABLE
STANDARD TYPE FASTENERS**

The torque values listed below are for standard-type fasteners only. The torque values listed are based on wet (lubricated) and dry conditions. The torque values for 1/4 and 5/16 inch size fasteners are listed in in-lbs torque only. The torque values for all other size fasteners are listed in ft-lbs torque with metric equivalents in parentheses. Use lower grade torque values if bolt and nut have different SAE grades. Manufacturer's SAE grade markings may vary.

STANDARD MARKINGS AND TORQUE SPECIFICATIONS

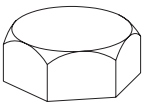
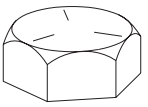
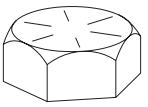
SAE Grade	1 or 2				5				8			
Fastener Standard SAE Grade Markings												
Fastener Body Size Inch Thrd	Wet Torque in-lb		Dry Torque in-lb		Wet Torque in-lb		Dry Torque in-lb		Wet Torque in-lb		Dry Torque in-lb	
1/4 - 20	49		65		75		100		107		142	
1/4 - 28	56		74		86		114		122		162	
5/16 - 18	103		137		157		208		220		293	
5/16 - 24	113		150		173		230		244		325	
Fastener Body Size Inch Thrd	Wet Torque (ft-lb (kg-m))		Dry Torque (ft-lb (kg-m))		Wet Torque (ft-lb (kg-m))		Dry Torque (ft-lb (kg-m))		Wet Torque (ft-lb (kg-m))		Dry Torque (ft-lb (kg-m))	
3/8 - 16	15	(2.1)	20	(2.8)	23	(3.2)	31	(4.2)	32	(4.4)	43	(5.9)
3/8 - 24	17	(2.4)	23	(3.1)	26	(3.6)	35	(4.8)	37	(5.1)	49	(6.8)
7/16 - 14	24	(3.3)	32	(4.4)	37	(5.1)	49	(6.8)	52	(7.2)	69	(9.6)
7/16 - 20	27	(3.7)	36	(5.0)	42	(5.8)	56	(7.7)	58	(8.0)	77	(10.7)
1/2 - 13	39	(5.4)	52	(7.2)	57	(7.9)	76	(10.5)	80	(11.0)	106	(14.7)
1/2 - 20	41	(5.7)	55	(7.5)	64	(8.9)	85	(11.8)	90	(12.4)	120	(16.5)
9/16 - 12	53	(7.3)	71	(9.7)	82	(11.3)	109	(15.1)	115	(15.9)	153	(21.1)
9/16 - 18	59	(8.2)	78	(10.8)	91	(12.6)	121	(16.7)	129	(17.8)	172	(23.7)
5/8 - 11	73	(10.0)	97	(13.4)	113	(15.6)	150	(20.8)	160	(22.1)	213	(29.4)
5/8 - 18	83	(11.5)	110	(15.2)	128	(17.7)	170	(23.5)	180	(24.9)	239	(33.1)
3/4 - 10	129	(17.8)	172	(23.7)	200	(27.7)	266	(36.8)	282	(39.0)	375	(51.8)
3/4 - 16	144	(19.9)	192	(26.5)	223	(30.8)	297	(41.0)	315	(43.6)	419	(57.9)
7/8 - 9	124	(17.1)	165	(22.8)	323	(44.7)	430	(59.4)	454	(62.8)	604	(83.5)
7/8 - 14	138	(19.1)	184	(25.4)	355	(49.1)	472	(65.3)	501	(69.3)	666	(92.1)
1 - 8	188	(26.0)	250	(34.6)	483	(66.8)	642	(88.9)	681	(94.2)	906	(125.2)
1 - 14	210	(29.0)	279	(38.6)	541	(74.8)	720	(99.5)	764	(106.0)	1,016	(140.5)
1-1/8 - 7	266	(36.8)	354	(48.9)	596	(82.4)	793	(109.6)	966	(134.0)	1,285	(177.6)
1-1/8 - 12	297	(41.1)	395	(54.6)	668	(92.4)	888	(122.8)	1,083	(150.0)	1,440	(199.1)
1-1/4 - 7	375	(51.9)	499	(69.0)	841	(116.0)	1,119	(154.6)	1,363	(189.0)	1,813	(250.6)
1-1/4 - 12	415	(57.4)	552	(76.3)	930	(129.0)	1,237	(171.0)	1,509	(209.0)	2,007	(277.5)
1-3/8 - 6	492	(68.0)	654	(90.5)	1,102	(152.0)	1,466	(202.6)	1,787	(247.0)	2,377	(328.6)
1-3/8 - 12	560	(77.4)	745	(103.0)	1,255	(174.0)	1,670	(230.8)	2,034	(281.0)	2,705	(374.0)
1-1/2 - 6	653	(90.3)	868	(120.1)	1,463	(202.0)	1,946	(269.0)	2,371	(328.0)	3,153	(436.0)
1-1/2 - 12	734	(102.0)	976	(135.0)	1,645	(228.0)	2,188	(302.5)	2,668	(369.0)	3,548	(490.6)

Appendix A

FIGURE 6-2
STANDARD BOLT TORQUE REQUIREMENTS TABLE
SERRATED TYPE FLANGE FASTENERS

The torque values listed below are for serrated-type flange fasteners only. The torque values listed are based on wet (lubricated) and dry conditions. The torque values for all size fasteners are listed in ft-lbs torque with metric equivalents in parentheses. Use lower grade torque values if bolt and nut have different SAE grades. Manufacturer's SAE grade markings may vary.

STANDARD MARKINGS AND TORQUE SPECIFICATIONS

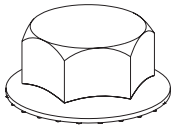
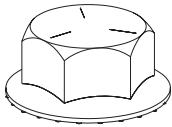
SAE Grade	1 or 2				5			
Fastener Standard SAE Grade Markings								
Fastener Body Size Inch Thrd	Torque				Torque			
	Wet ft-lb	(kg-m)	Dry ft-lb	(kg-m)	Wet ft-lb	(kg-m)	Dry ft-lb	(kg-m)
1/4 - 20	8	(1.1)	11	(1.5)	11	(1.5)	15	(2.1)
1/4 - 28	9	(1.2)	12	(1.7)	12	(1.7)	16	(2.2)
5/16 - 18	13	(1.8)	17	(2.4)	20	(2.8)	27	(3.7)
5/16 - 24	13	(1.8)	17	(2.4)	32	(4.4)	43	(5.9)
3/8 - 16	23	(3.2)	31	(4.3)	40	(5.5)	53	(7.3)
3/8 - 24	25	(3.5)	33	(4.6)	43	(5.9)	57	(7.9)
7/16 - 14	38	(5.3)	51	(7.1)	55	(7.6)	73	(10.1)
7/16 - 20	40	(5.5)	53	(7.5)	60	(8.3)	80	(11.1)
1/2 - 13	60	(8.3)	80	(11.1)	95	(13.1)	127	(17.6)
1/2 - 20	65	(9.0)	87	(12.0)	100	(13.8)	133	(18.4)
9/16 - 12	78	(10.8)	104	(14.4)	140	(19.4)	187	(25.9)
9/16 - 18	85	(11.8)	113	(15.6)	150	(20.7)	200	(27.7)
5/8 - 11	125	(17.3)	167	(23.1)	190	(26.3)	253	(35.0)
5/8 - 18	135	(18.7)	180	(24.9)	220	(30.4)	293	(40.5)
3/4 - 10	225	(31.1)	300	(41.2)	350	(48.4)	467	(64.6)
3/4 - 16	250	(34.6)	333	(46.1)	400	(55.3)	533	(73.7)
7/8 - 9	350	(48.4)	467	(64.6)	550	(76.1)	733	(101.4)
7/8 - 14	375	(51.9)	500	(69.2)	600	(83.0)	800	(110.6)
1 - 8	480	(66.4)	640	(88.5)	750	(103.7)	1,000	(138.3)
1 - 14	500	(69.2)	666	(92.1)	800	(110.6)	1,066	(147.4)

Appendix A

**FIGURE 6-3
BOLT TORQUE REQUIREMENTS TABLE
METRIC TYPE FASTENERS**

Do not use these values if a different torque value or tightening procedure is given for a specific application. Torque values listed are for general use only. Check tightness of fasteners periodically. Fasteners should be replaced with the same or higher property class. If higher property class fasteners are used, these should only be tightened to the strength of the original. Make sure fastener's threads are clean and that thread engagement is properly started. This will help prevent them from failing when tightening.

* Lubricated means coated with a lubricant such as engine oil, or fasteners with phosphate and oil coatings. Dry means plain or zinc plated without any lubrication.

Property Class and Head Markings	4.8				8.8				9.8							
	5				10											
Property Class and Head Markings																
Size	Class 4.8								Class 8.8 or 9.8							
	* Lubricated				* Dry				* Lubricated				* Dry			
	N - m		lb - ft		N - m		lb - ft		N - m		lb - ft		N - m		lb - ft	
M 6	4.8	3.5	6	4.5	9	6.5	11	8.5								
M 8	12	8.5	15	11	22	16	28	20								
M10	23	17	29	21	43	32	55	40								
M12	40	29	50	37	75	55	95	70								
M14	63	47	80	60	120	88	150	110								
M16	100	73	125	92	190	140	240	175								
M18	135	100	175	125	260	195	330	250								
M20	190	140	240	180	375	275	475	350								
M22	260	190	330	250	510	375	650	475								
M24	330	250	425	310	650	475	825	600								
M27	490	360	625	450	950	700	1200	875								
M30	675	490	850	625	1300	950	1650	1200								
M33	900	675	1150	850	1750	1300	2200	1650								
M36	1150	850	1450	1075	2250	1650	2850	2100								

Appendix A

FIGURE 6-4
BOLT TORQUE REQUIREMENTS TABLE
METRIC TYPE FASTENERS

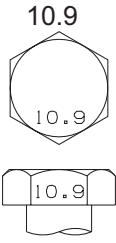
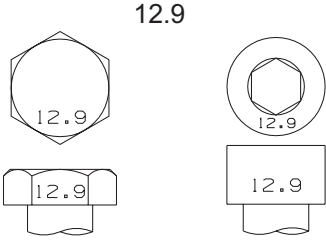
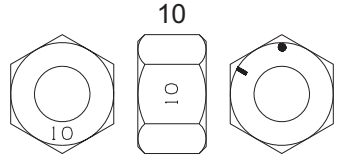
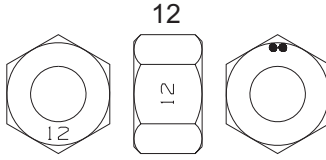
Property Class and Head Markings								
Property Class and Head Markings								
Size	Class 10.9				Class 12.9			
	* Lubricated		* Dry		* Lubricated		* Dry	
	N - m	lb - ft	N - m	lb - ft	N - m	lb - ft	N - m	lb - ft
M 6	13	9.5	17	12	15	11.5	19	14.5
M 8	32	24	40	30	37	28	47	35
M10	63	47	80	60	75	55	95	70
M12	110	80	140	105	130	95	165	120
M14	175	130	225	165	205	150	260	190
M16	275	200	350	255	320	240	400	300
M18	375	275	475	350	440	325	560	410
M20	530	400	675	500	625	460	800	580
M22	725	540	925	675	850	625	1075	800
M24	925	675	1150	850	1075	800	1350	1000
M27	1350	1000	1700	1250	1600	1150	2000	1500
M30	1850	1350	2300	1700	2150	1600	2700	2000
M33	2500	1850	3150	2350	2900	2150	3700	2750
M36	3200	2350	4050	3000	3750	2750	4750	3500

Appendix A

FIGURE 6-5
INCH TO MILLIMETER CONVERSION TABLE
1 INCH = 25.4 MILLIMETERS

FRACTIONS	DECIMALS	MILLIMETERS	FRACTIONS	DECIMALS	MILLIMETERS
	1/64	.016		0.397	
1/32	.031	0.794	17/32	.531	13.494
	3/64	.047		1.191	13.891
1/16	.063	1.588	9/16	.563	14.288
	5/64	.078		1.984	14.684
3/32	.094	2.381	19/32	.594	15.081
	7/64	.109		2.778	15.478
1/8	.125	3.175	5/8	.625	15.875
	9/64	.141		3.572	16.272
5/32	.156	3.969	21/32	.656	16.669
	11/64	.172		4.366	17.066
3/16	.188	4.763	11/16	.688	17.463
	13/64	.203		5.159	17.859
7/32	.219	5.556	23/32	.719	18.256
	15/64	.234		5.953	18.653
1/4	.250	6.350	3/4	.750	19.050
	17/64	.266		6.747	19.447
9/32	.281	7.144	25/32	.781	19.844
	19/64	.297		7.541	20.241
5/16	.313	7.938	13/16	.813	20.638
	21/64	.328		8.334	21.034
11/32	.344	8.731	27/32	.844	21.431
	23/64	.359		9.128	21.828
3/8	.375	9.525	7/8	.875	22.225
	25/64	.391		9.922	22.622
13/32	.406	10.319	29/32	.906	23.019
	27/64	.422		10.716	23.416
7/16	.438	11.113	15/16	.938	23.813
	29/64	.453		11.509	24.209
15/32	.469	11.906	31/32	.969	24.606
	31/64	.484		12.303	25.003
1/2	.500	12.700	1	1.000	25.400

FIGURE 6-6
FEET TO METERS CONVERSION TABLE
1 FOOT = 0.3048 METER

FEET	METERS	FEET	METERS	FEET	METERS	FEET	METERS	FEET	METERS
100	30.480	10	3.048	1	0.305	0.1	0.030	0.01	0.003
200	60.960	20	6.096	2	0.610	0.2	0.061	0.02	0.006
300	91.440	30	9.144	3	0.914	0.3	0.091	0.03	0.009
400	121.920	40	12.192	4	1.219	0.4	0.122	0.04	0.012
500	152.400	50	15.240	5	1.524	0.5	0.152	0.05	0.015
600	182.880	60	18.288	6	1.829	0.6	0.183	0.06	0.018
700	213.360	70	21.336	7	2.134	0.7	0.213	0.07	0.021
800	243.840	80	24.384	8	2.438	0.8	0.244	0.08	0.024
900	274.320	90	27.432	9	2.743	0.9	0.274	0.09	0.027
1,000	304.800	100	30.480	10	3.048	1.0	0.305	0.10	0.030

6

Appendix A

FIGURE 6-7
POUNDS TO KILOGRAMS CONVERSION TABLE
1 POUND = 0.4536 KILOGRAM

LB	KG	LB	KG	LB	KG	LB	KG	LB	KG
1,000...	453.59	100.....	45.36	10.....	4.54	1.....	0.45	0.1.....	0.05
2,000...	907.18	200.....	90.72	20.....	9.07	2.....	0.91	0.2.....	0.09
3,000...	1,360.78	300.....	136.08	30.....	13.61	3.....	1.36	0.3.....	0.14
4,000...	1,814.37	400.....	181.44	40.....	18.14	4.....	1.81	0.4.....	0.18
5,000...	2,267.96	500.....	226.80	50.....	22.68	5.....	2.27	0.5.....	0.23
6,000...	2,721.55	600.....	272.16	60.....	27.22	6.....	2.72	0.6.....	0.27
7,000...	3,175.15	700.....	317.51	70.....	31.75	7.....	3.18	0.7.....	0.32
8,000...	3,628.74	800.....	362.87	80.....	36.29	8.....	3.63	0.8.....	0.36
9,000...	4,082.33	900.....	408.23	90.....	40.82	9.....	4.08	0.9.....	0.41
10,000...	4,535.92	1,000.....	453.59	100.....	45.36	10.....	4.54	1.0.....	0.45

FIGURE 6-8
POUNDS PER SQUARE INCH TO BAR CONVERSION TABLE
1 PSI = 0.06895 BAR

PSI	BAR	PSI	BAR	PSI	BAR	PSI	BAR
1,000.....	68.95	100.....	6.90	10.....	0.69	1.....	0.07
2,000.....	137.90	200.....	13.79	20.....	1.38	2.....	0.14
3,000.....	206.84	300.....	20.68	30.....	2.07	3.....	0.21
4,000.....	275.80	400.....	27.58	40.....	2.76	4.....	0.28
5,000.....	344.70	500.....	34.47	50.....	3.45	5.....	0.35
6,000.....	413.64	600.....	41.36	60.....	4.14	6.....	0.41
7,000.....	482.58	700.....	48.26	70.....	4.83	7.....	0.48
8,000.....	551.52	800.....	55.15	80.....	5.52	8.....	0.55
9,000.....	620.46	900.....	62.05	90.....	6.21	9.....	0.62
10,000.....	689.48	1,000.....	68.95	100.....	6.90	10.....	0.69

FIGURE 6-9
POUNDS PER SQUARE INCH TO
KILOPASCALS CONVERSION TABLE
1 PSI = 6.895 kPa

PSI	kPa	PSI	kPa
10.....	68.95	1.....	6.90
20.....	137.90	2.....	13.79
30.....	206.84	3.....	20.68
40.....	275.80	4.....	27.58
50.....	344.70	5.....	34.47
60.....	413.64	6.....	41.36
70.....	482.58	7.....	48.26
80.....	551.52	8.....	55.15
90.....	620.46	9.....	62.05
100.....	689.48	10.....	68.95

Appendix A

FIGURE 6-10
FAHRENHEIT TO CELSIUS (Centigrade) CONVERSION TABLE
(DEGREES F - 32°) ÷ 1.8 = DEGREES C

deg F	deg C	deg F	deg C	deg F	deg C	deg F	deg C
1	-17.2	51	10.6	101	38.3	151	66.1
2	-16.7	52	11.1	102	38.9	152	66.7
3	-16.1	53	11.7	103	39.4	153	67.2
4	-15.6	54	12.2	104	40.0	154	67.8
5	-15.0	55	12.8	105	40.6	155	68.3
6	-14.4	56	13.3	106	41.1	156	68.9
7	-13.9	57	13.9	107	41.7	157	69.4
8	-13.3	58	14.4	108	42.2	158	70.0
9	-12.8	59	15.0	109	42.8	159	70.6
10	-12.2	60	15.6	110	43.3	160	71.1
11	-11.7	61	16.1	111	43.9	161	71.7
12	-11.1	62	16.7	112	44.4	162	72.2
13	-10.6	63	17.2	113	45.0	163	72.8
14	-10.0	64	17.8	114	45.6	164	73.3
15	-9.4	65	18.3	115	46.1	165	73.9
16	-8.9	66	18.9	116	46.7	166	74.4
17	-8.3	67	19.4	117	47.2	167	75.0
18	-7.8	68	20.0	118	47.8	168	75.6
19	-7.2	69	20.6	119	48.3	169	76.1
20	-6.7	70	21.1	120	48.9	170	76.7
21	-6.1	71	21.7	121	49.4	171	77.2
22	-5.6	72	22.2	122	50.0	172	77.8
23	-5.0	73	22.8	123	50.6	173	78.3
24	-4.4	74	23.3	124	51.1	174	78.9
25	-3.9	75	23.9	125	51.7	175	79.4
26	-3.3	76	24.4	126	52.2	176	80.0
27	-2.8	77	25.0	127	52.8	177	80.6
28	-2.2	78	25.6	128	53.3	178	81.1
29	-1.7	79	26.1	129	53.9	179	81.7
30	-1.1	80	26.7	130	54.4	180	82.2
31	-0.6	81	27.2	131	55.0	181	82.8
32	0.0	82	27.8	132	55.6	182	83.3
33	0.6	83	28.3	133	56.1	183	83.9
34	1.1	84	28.9	134	56.7	184	84.4
35	1.7	85	29.4	135	57.2	185	85.0
36	2.2	86	30.0	136	57.8	186	85.6
37	2.7	87	30.6	137	58.3	187	86.1
38	3.3	88	31.1	138	58.9	188	86.7
39	3.9	89	31.7	139	59.4	189	87.2
40	4.4	90	32.2	140	60.0	190	87.8
41	5.0	91	32.8	141	60.6	191	88.3
42	5.6	92	33.3	142	61.1	192	88.9
43	6.1	93	33.9	143	61.7	193	89.4
44	6.7	94	34.4	144	62.2	194	90.0
45	7.2	95	35.0	145	62.8	195	90.6
46	7.8	96	35.6	146	63.3	196	91.1
47	8.3	97	36.1	147	63.9	197	91.7
48	8.9	98	36.7	148	64.4	198	92.2
49	9.4	99	37.2	149	65.0	199	92.8
50	10.0	100	37.8	150	65.6	200	93.3

Appendix A

FIGURE 6-11
MILES PER HOUR TO KILOMETERS
PER HOUR CONVERSION TABLE
1 MPH = 1.609 KM/H

MPH	KM/H	MPH	KM/H	MPH	KM/H
10	16.09	1	1.61	0.1	0.16
20	32.19	2	3.22	0.2	0.32
30	48.28	3	4.83	0.3	0.48
40	64.37	4	6.44	0.4	0.64
50	80.47	5	8.05	0.5	0.80
60	96.56	6	9.66	0.6	0.97
70	112.65	7	11.27	0.7	1.13
80	128.75	8	12.87	0.8	1.29
90	144.84	9	14.48	0.9	1.45
100	160.93	10	16.09	1.0	1.61

FIGURE 6-12
U.S. GALLONS TO LITERS CONVERSION TABLE
1 U.S. GALLON = 3.785 LITERS

GAL	LITER	GAL	LITER	GAL	LITER	GAL	LITER
100	378.54	10	37.85	1	3.79	0.1	0.38
200	757.08	20	75.71	2	7.57	0.2	0.76
300	1,135.62	30	113.56	3	11.36	0.3	1.14
400	1,514.16	40	151.42	4	15.14	0.4	1.51
500	1,892.71	50	189.27	5	18.93	0.5	1.89
600	2,271.25	60	227.12	6	22.71	0.6	2.27
700	2,649.79	70	264.98	7	26.50	0.7	2.65
800	3,028.33	80	302.83	8	30.28	0.8	3.03
900	3,406.87	90	340.69	9	34.07	0.9	3.41
1,000	3,785.41	100	378.54	10	37.85	1.0	3.79

Appendix B

DISCLAIMER

HARSCO TRACK TECHNOLOGIES, HARSCO CORPORATION RECOMMENDS THAT ALL HOSE, HOSE ASSEMBLIES AND/OR FITTINGS REPLACED BY THE CUSTOMER SHOULD BE EQUAL TO OR EXCEED THE CURRENT SPECIFICATIONS OF THE ORIGINAL EQUIPMENT SUPPLIED BY HARSCO TRACK TECHNOLOGIES, HARSCO CORPORATION. HARSCO TRACK TECHNOLOGIES, HARSCO CORPORATION WILL NOT BE LIABLE FOR ANY CLAIMS OF PERSONAL INJURY RESULTING FROM THE USE OF HOSE, HOSE ASSEMBLIES AND/OR FITTINGS THAT DO NOT MEET CURRENT ORIGINAL EQUIPMENT SPECIFICATIONS. THE CUSTOMER IS ADVISED TO COMPLY WITH SAE J1273 NOVEMBER 1991, SELECTION, INSTALLATION, AND MAINTENANCE OF HOSE AND HOSE ASSEMBLIES.

SAE J1273 - NOVEMBER 1991*

SELECTION, INSTALLATION AND MAINTENANCE OF HOSE AND HOSE ASSEMBLIES

1. **SCOPE** - Hose (also includes hose assemblies) has a finite life and there are a number of factors which will reduce its life.

This SAE recommended practice is intended as a guide to assist system designers and/or users in the selection, installation, and maintenance of hose. The designers and users must make a systematic review of each application and then select, install, and maintain the hose to fulfill the requirements of the application. The following are general guidelines and are not necessarily a complete list.

6



- **IMPROPER SELECTION, INSTALLATION, OR MAINTENANCE MAY RESULT IN PREMATURE FAILURES, BODILY INJURY, OR PROPERTY DAMAGE.**

2. REFERENCES

- 2.1 **Applicable Documents** - The following publications form a part of this specification to the extent specified herein. The latest issue of SAE publications shall apply.
 - 2.1.1 **SAE Publications** - Available from SAE, 400 Commonwealth Drive, Warrendale, PA 15096-0001.
 - J516 - Hydraulic Hose Fittings
 - J517 - Hydraulic Hose
3. **SELECTION** - The following is a list of factors which must be considered before final hose selection can be made.
 - 3.1 **Pressure** - After determining the system pressure, hose selection must be made so that the recommended maximum operating pressure is equal to or greater than the system pressure. Surge pressures higher than the maximum operating pressure will shorten hose life and must be taken into account by the hydraulic designer.

Appendix B

- 3.2 Suction** - Hoses used for suction applications must be selected to insure the hose will withstand the negative pressure of the system.
- 3.3 Temperature** - Care must be taken to insure that fluid and ambient temperatures, both static and transient, do not exceed the limitations of the hose. Special care must be taken when routing near hot manifolds.
- 3.4 Fluid Compatibility** - Hose selection must assure compatibility of the hose tube, cover, and fittings with the fluid used. Additional caution must be observed in hose selection for gaseous applications.
- 3.5 Size** - Transmission of power by means of pressurized fluid varies with pressure and rate of flow. The size of the components must be adequate to keep pressure losses to a minimum and avoid damage to the hose due to heat generation or excessive turbulence.
- 3.6 Routing** - Attention must be given to optimum routing to minimize inherent problems.
- 3.7 Environment** - Care must be taken to insure that the hose and fittings are either compatible with or protected from the environment to which they are exposed. Environmental conditions such as ultraviolet light, ozone, salt water, chemicals, and air pollutants can cause degradation and premature failure, and, therefore, must be considered.
- 3.8 Mechanical Loads** - External forces can significantly reduce hose life. Mechanical loads which must be considered include excessive flexing, twist, kinking, tensile or side loads, bend radius, and vibration. Use of swivel type fittings or adapters may be required to insure no twist is put into the hose. Unusual applications may require special testing prior to hose selection.
- 3.9 Abrasion** - While a hose is designed with a reasonable level of abrasion resistance, care must be taken to protect the hose from excessive abrasion which can result in erosion, snagging and cutting of the hose cover. Exposure of the reinforcement will significantly accelerate hose failure.
- 3.10 Proper End Fitting** - Care must be taken to insure proper compatibility exists between the hose and coupling selected based on the manufacturer's recommendations substantiated by testing to industry standards such as SAE J517. End fitting components from one manufacturer are usually not compatible with end fitting components supplied by another manufacturer (i.e., using a hose fitting nipple from one manufacturer with a hose socket from another manufacturer). It is the responsibility of the fabricator to consult the manufacturer's written instructions or the manufacturer directly for proper end fitting componentry.

Appendix B

- 3.11 Length** - When establishing proper hose length, motion absorption, hose length changes due to pressure, as well as hose and machine tolerances must be considered.
- 3.12 Specifications and Standards** - When selecting hose, government, industry, and manufacturer's specifications and recommendations must be reviewed as applicable.
- 3.13 Hose Cleanliness** - Hose components vary in cleanliness levels. Care must be taken to insure that the assemblies selected have an adequate level of cleanliness for the application.
- 3.14 Electrical Conductivity** - Certain applications require that the hose be non-conductive to prevent electrical current flow. Other applications require the hose to be sufficiently conductive to drain off static electricity. Hose and fittings must be chosen with these needs in mind.
- 4. INSTALLATION** - After selection of proper hose, the following factors must be considered by the installer.
- 4.1 Pre-Installation Inspection** - Prior to installation, a careful examination of the hose must be performed. All components must be checked for correct style, size, and length. In addition, the hose must be examined for cleanliness, I.D. obstructions, blisters, loose cover, or any other visible defects.
- 4.2 Follow Manufacturers' Assembly Instructions** - Hose assemblies may be fabricated by the manufacturer, an agent for or customer of the manufacturer, or by the user. Fabrication of permanently attached fittings to hydraulic hose requires specialized assembly equipment. Field-attachable fittings (screw style and segment clamp style) can usually be assembled without specialized equipment although many manufacturers provide equipment to assist in this operation. SAE J517 hose from one manufacturer is not compatible with SAE J516 fittings supplied by another manufacturer. It is the responsibility of the fabricator to consult the manufacturer's written assembly instructions or the manufacturers directly before intermixing hose and fittings from two manufacturers. Similarly, assembly equipment from one manufacturer is usually not interchangeable with that of another manufacturer. It is the responsibility of the fabricator to consult the manufacturer's written instructions or the manufacturer directly for proper assembly equipment. Always follow the manufacturer's instructions for proper preparation and fabrication of hose assemblies.
- 4.3 Minimum Bend Radius** - Installation at less than minimum bend radius may significantly reduce hose life. Particular attention must be given to preclude sharp bending at the hose / fitting juncture.
- 4.4 Twist Angle and Orientation** - Hose installations must be such that relative motion of machine components produces bending of the hose rather than twisting.

Appendix B

- 4.5 Securement** - In many applications, it may be necessary to restrain, protect, or guide the hose to protect it from damage by unnecessary flexing, pressure surges, and contact with other mechanical components. Care must be taken to insure such restraints do not introduce additional stress or wear points.
- 4.6 Proper Connection of Ports** - Proper physical installation of the hose requires a correctly installed port connection while insuring that no twist or torque is put into the hose.
- 4.7 Avoid External Damage** - Proper installation is not complete without insuring that tensile loads, side loads, kinking, flattening, potential abrasion, thread damage, or damage to sealing surfaces are corrected or eliminated.
- 4.8 System Check Out** - After completing the installation, all air entrapment must be eliminated and the system pressurized to the maximum system pressure and checked for proper function and freedom from leaks.

Note: Avoid potential hazardous areas while testing.

Appendix B

5. **MAINTENANCE** - Even with proper selection and installation, hose life may be significantly reduced without a continuing maintenance program. Frequency should be determined by the severity of the application and risk potential. A maintenance program should include the following as a minimum.
- 5.1 **Hose Storage** - Hose products in storage can be affected adversely by temperature, humidity, ozone, sunlight, oils, solvents, corrosive liquids and fumes, insects, rodents and radioactive materials. Storage areas should be relatively cool and dark and free of dust, dirt, dampness, and mildew.
- 5.2 **Visual Inspection** - Any of the following conditions requires replacement of the hose:
- Leaks at fitting or in hose (leaking fluid is a fire hazard)
 - Damaged, cut, or abraded cover (any reinforcement exposed)
 - Kinked, crushed, flattened, or twisted hose
 - Hard, stiff, heat cracked, or charred hose
 - Blistered, soft degraded, or loose cover
 - Cracked, damaged, or badly corroded fittings
 - Fitting slippage on hose
- 5.3 **Visual Inspection** - The following items must be tightened, repaired, or replaced as required:
- Leaking port conditions
 - Clamps, guards, shields
 - Remove excessive dirt buildup
 - System fluid level, fluid type, and any air entrapment
- 5.4 **Functional Test** - Operate the system at maximum operating pressure and check for possible malfunctions and freedom from leaks.
- Note: Avoid potential hazardous areas while testing.*
- 5.5 **Replacement Intervals** - Specific replacement intervals must be considered based on previous service life, government or industry recommendations, or when failures could result in unacceptable down time, damage, or injury risk.

**SECTION 7 - PARTS
TABLE OF CONTENTS**

SERIAL NUMBERS 7 - 3

INSTRUCTIONS FOR ORDERING PARTS 7 - 4

LIMITED WARRANTY 7 - 5

PRODUCT IMPROVEMENT LIABILITY DISCLAIMER 7 - 5

HAZARDOUS MATERIAL DISCLAIMER 7 - 5

GUIDE WHEEL UNIT - 179546 7 - 6

GUIDE WHEEL ASSEMBLY 7 - 9

HYDRAULIC PIPING - 179546 GUIDE WHEEL UNIT 7 - 10

AIR BRAKE PIPING - 179546 GUIDE WHEEL UNIT 7 - 11

STEERING LOCK GROUPS 7 - 12

RAIL SWEEP GROUP - 179557 7 - 13

TRUCK BRAKE CONNECTION

 154057 7 - 14

 162114 7 - 16

 162130 7 - 18

 179161 7 - 20

HYDRAULIC POWER PACK, FULL - 137926 7 - 22

HYDRAULIC POWER PACK, ABBREVIATED - 137927 7 - 26

SIGHT ROD EXTENSION GROUP - 164574 7 - 28

DECAL SERVICE GROUP - 180781 7 - 28

MOUNTING BRACKET GROUPS

 179139 7 - 29

 179543 7 - 30

 179544 7 - 31

 179948 7 - 32

 184159 7 - 33

 184170 7 - 34

 193979 7 - 35

Serial Numbers

When this bulletin is received, complete the following record from the serial number tag on front guide wheel unit. Always mention these factory serial numbers when calling or writing about the unit. The serial number tag is located on the frame mounting assembly.

HTT Harsco Track Technologies a harsco company™		PATENT NUMBER <input type="text"/>
WHEN ORDERING PARTS FOR THIS ACCESSORY ALWAYS GIVE THE FOLLOWING INFORMATION		
Fairmont ™ HY-RAIL® GUIDE WHEEL EQUIPMENT		
SERIAL NUMBER <input type="text"/>	SYMBOL <input type="text"/>	MODEL NUMBER <input type="text"/>
FAIRMONT, MN. 56031 U.S.A.		
52400K		

Instructions For Ordering Parts

1. See Section 8 for the Vehicle Application charts.
2. Find the chart for the make, model and year of the vehicle that the unit is mounted on.
3. Each application consists of required groups, optional groups required and accessory group options. These are the group numbers that were supplied with, or that were available for the unit.
4. Locate the appropriate group numbers in the Parts Section to find the individual parts required.
5. Front - rear and left - right are determined from the operator's position.
6. Assemblies: Items listed in CAPITALS are assemblies which include all parts listed immediately following and with the part description indented to the right. When assemblies can be used, always order them to save work of fitting separate parts.
7. For convenience in ordering, parts are listed by item number, part number, description, and quantity in each assembly or group. If in doubt as to any part wanted, send full description, sketch, or send the old part with the order.
8. To insure prompt and correct shipment of parts on orders, always give:
 - a. Quantity of each part wanted.
 - b. Part number of each part as shown in this book. Include any prefix and suffix letters.
 - c. Description of each part as shown in this book.
 - d. Factory serial numbers recorded above.
 - e. Purchase order number (if required).
 - f. Preferred method of shipment.
9. All parts are shipped F.O.B. factory, transportation charges to be paid by customer. Terms to be determined by the Credit Department.

Limited Warranty

HARSCO TRACK TECHNOLOGIES products are designed to give high quality service and are manufactured from high grade material, by competent workmen under careful supervision. Harsco Track Technologies, Harsco Corporation warrants products of its manufacture to be free of defects in material and workmanship, under normal use and service for a period of six (6) months from date of delivery to the original user. The obligation of Harsco Track Technologies, Harsco Corporation under this warranty is limited to repairing or replacing at its factories, or other location designated by it, any part or parts thereof which are returned within 30 days of the date when failure occurs or defect is noted, with transportation charges prepaid, and which upon examination appears to the satisfaction of Harsco Track Technologies, Harsco Corporation to have been defective. Such free repair or replacement does not include transportation charges, or the cost of installing the new part or any other expense incident thereto. Harsco Track Technologies, Harsco Corporation will not be liable for other loss, damage, or expense directly or indirectly arising from the use of its products, nor will Harsco Track Technologies, Harsco Corporation be liable for special, incidental or consequential damages.

Ordinary wear and tear, and damage from abuse, misuse, neglect or alteration are not covered by this warranty. Harsco Track Technologies, Harsco Corporation assumes no liability for expenses incurred or repairs made outside its factories except by written consent. This warranty is null and void if instructions and operating procedures are not followed.

Equipment or parts not manufactured by this company, but which are furnished in connection with HARSCO TRACK TECHNOLOGIES products, are covered directly by the warranty of the manufacturer supplying them. However, Harsco Track Technologies, Harsco Corporation will assist in obtaining adjustment on such equipment or parts when necessary.

THIS WARRANTY IS IN LIEU OF ALL OTHER WARRANTIES EXPRESSED OR IMPLIED INCLUDING ANY IMPLIED WARRANTIES OF MERCHANTABILITY OR FITNESS FOR A PARTICULAR PURPOSE AND OF ANY OTHER OBLIGATION OR LIABILITY OF HARSCO TRACK TECHNOLOGIES, HARSCO CORPORATION.

Product Improvement Liability Disclaimer

HARSCO TRACK TECHNOLOGIES, HARSCO CORPORATION RESERVES THE RIGHT TO MAKE ANY CHANGES IN OR IMPROVEMENTS ON ITS PRODUCTS WITHOUT INCURRING ANY LIABILITY OR OBLIGATION WHATEVER AND WITHOUT BEING REQUIRED TO MAKE ANY CORRESPONDING CHANGES OR IMPROVEMENTS IN PRODUCTS PREVIOUSLY MANUFACTURED OR SOLD.

7

Hazardous Material Disclaimer

THE PARTS/ASSEMBLIES THAT ARE USED IN THIS PRODUCT ARE CLASSIFIED AS "ARTICLES" ACCORDING TO 29 CFR 1910.1200 (C). THEY ARE FORMED TO A SPECIFIC SHAPE OR DESIGN DURING MANUFACTURE, HAVE END USE FUNCTION DEPENDENT UPON THEIR SHAPE OR DESIGN, AND DO NOT RELEASE ANY HAZARDOUS CHEMICAL UNDER NORMAL CONDITIONS OF USE. ACCORDINGLY, WE ARE NOT REQUIRED TO SUPPLY MATERIAL SAFETY DATA SHEETS (MSDS) OR TO LABEL SHIPPING CONTAINERS FOR "ARTICLES". HOWEVER, LUBRICANTS, LIQUIDS, GASEOUS CHEMICALS AND SOLIDS USED IN OPERATION OR MAINTENANCE OF THE PRODUCT MAY REQUIRE THAT USER'S TAKE OCCUPATIONAL PROTECTIVE MEASURES. MSDS SHEETS FOR SUCH MATERIALS WILL BE SUPPLIED TO YOUR PURCHASING MANAGER/SAFETY DIRECTOR TO BE USED IN YOUR EMPLOYEE SAFETY TRAINING EDUCATION AND ENVIRONMENTAL HEALTH TRAINING.

179546 GUIDE WHEEL UNIT

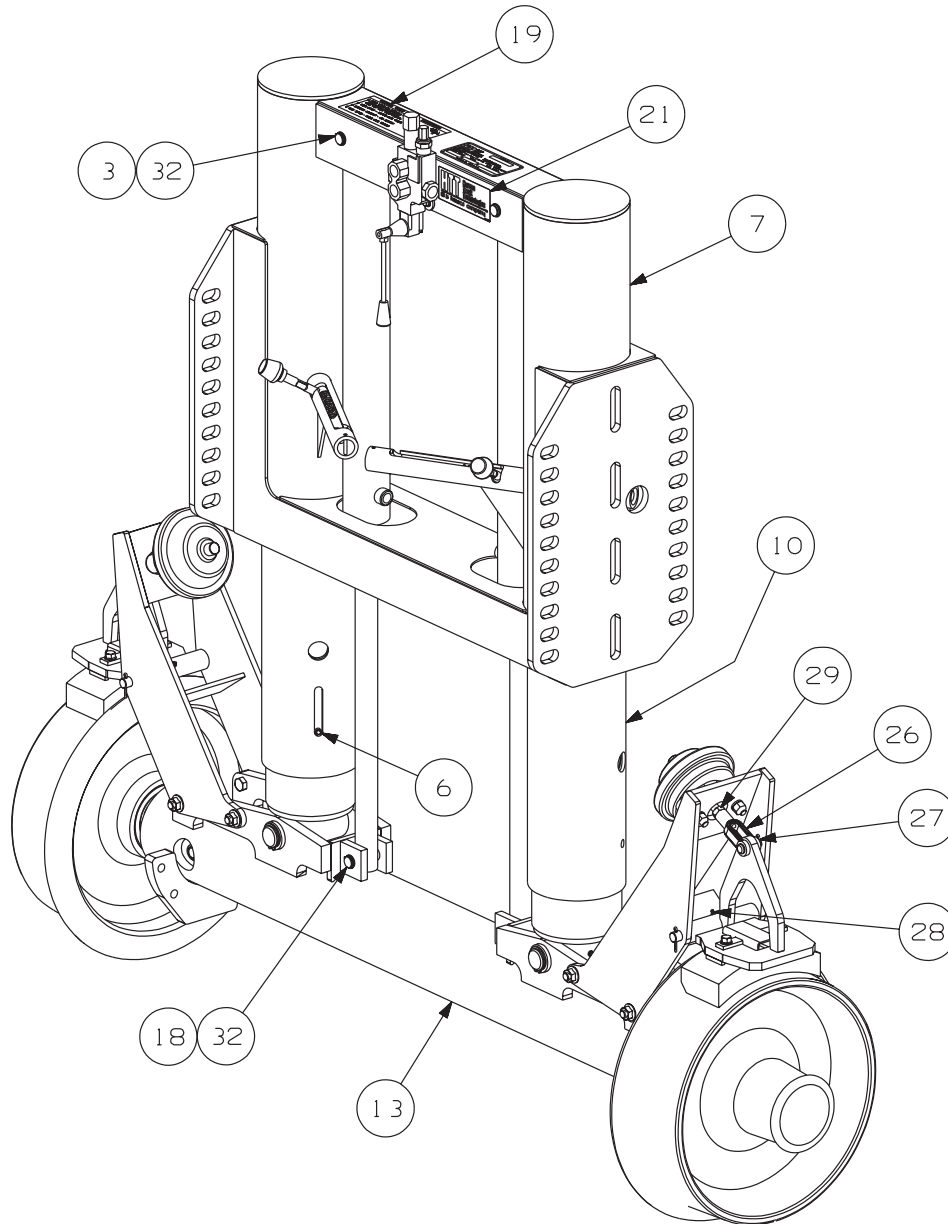

SE179546A-2

179546 GUIDE WHEEL UNIT

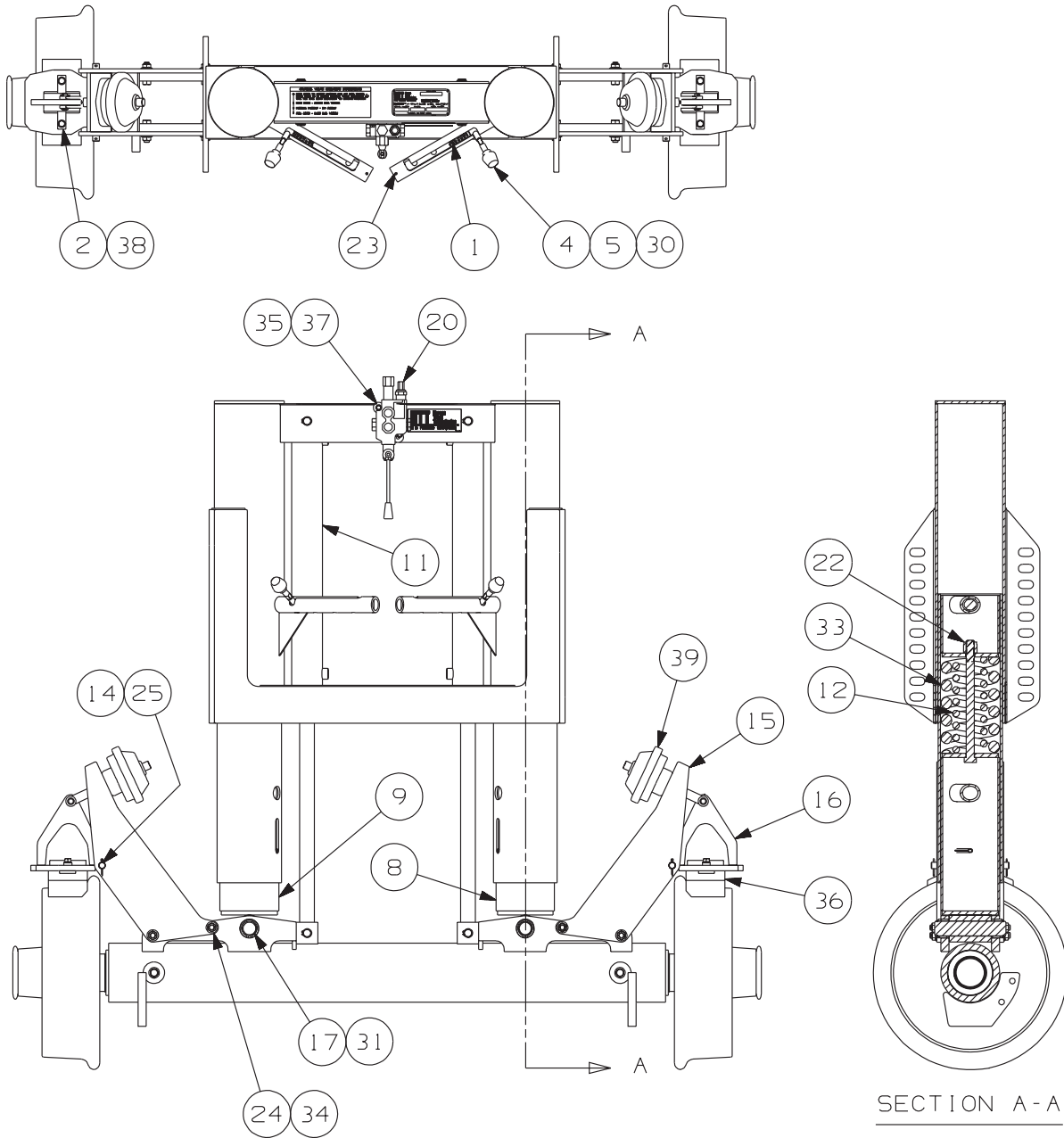

179546 GUIDE WHEEL UNIT

ITEM	PART NO	DESCRIPTION	QTY
1	083453K	Spring	2
2	157694	Link	2
3	178067	Pin	2
4	178088	Pin	2
5	178105	Stud	2
6	178106	Spring Pin, 3/8 x 5-3/4"	2
7	179167	Frame	1
8	179173	Inner Spring Cell, Left	1
9	179181	Inner Spring Cell, Right	1
10	179182	Outer Spring Cell Tube	2
11	179192	HYDRAULIC CYLINDER	2
	188634	Seal Kit	1
12	179490	Spring	2
13	179496	AXLE ASSEMBLY	1
	F025249	Hex Slotted Nut, 1-1/2"-12	2
	F003150	Cotter Pin, 3/16 x 2-1/2"	2
14	179537	Pin	2
15	179538	Brake Bracket	2
16	179539	Brake Shoe Mount	2
17	179916	Pin	2
18	179917	Pin	2
19	184073	Decal, Control Valve Operating Instructions	1
20	184462	Control Valve	1
21	191761	Decal, Harsco Track Technologies	1
22	700666075	Hex Lock Nut, 3/4"-10	2
23	700751150	Spring Pin 3/16 x 1-1/2"	2
24	F001095	Cap Screw, 1/2-13 x 1-3/4" Hex Hd	8
25	F001182	Cotter Pin, 1/8 x 1-1/4"	4
26	F005459	Adjustable Yoke End	2
27	F005460	Yoke Pin With Cotter Pin	2
28	F008014	Grease Fitting	4
29	F011013	Hex Jam Nut, 1/2"-20	2
30	F014260K	Knob	2
31	F015600	Retaining Ring	4
32	F018844	Retaining Ring	8
33	F019705	Spring	2
34	F022037	Hex Flg Nut, 1/2"-13	8
35	F022138	Hex Flg Nut, 1/4"-20	2
36	F022274	Brake Shoe	2
37	F023403	Cap Screw, 1/4-20 x 1-1/4" Hex Flg Hd	2
38	F023416	Cap Screw, 3/8-16 x 3/4" Hex Flg Hd	4
39	F025058	Brake Actuator	2

GUIDE WHEEL ASSEMBLY

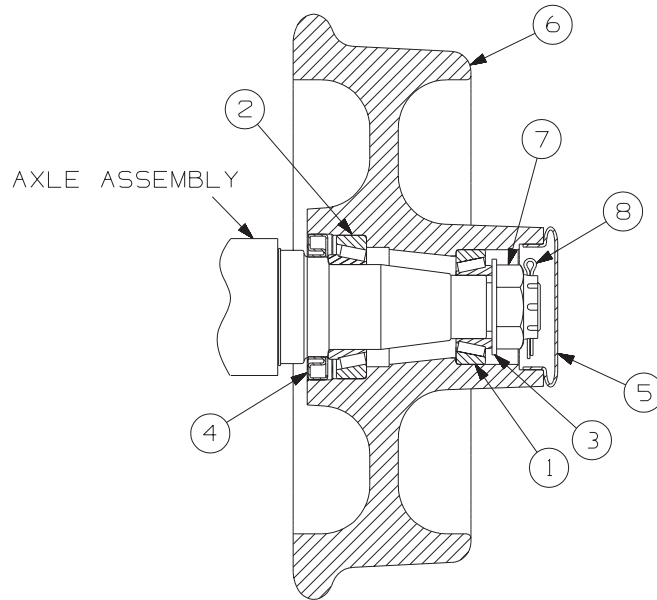

SE179546A-4

Note: Quantities listed are for one wheel only.

ITEM	PART NO	DESCRIPTION	QTY
1	159508	Bearing Cup And Cone, Outside	1
2	159507	Bearing Cup And Cone, Inside.	1
3	F025049	Washer.	1
4	F025057	Grease Seal	1
5	F025011	Grease Cap	1
6	175661	Wheel	1
7	F025249	Hex Slotted Nut, 1-1/2"-12	1
8	F003150	Cotter Pin, 3/16 x 2-1/2".	1

179546 GUIDE WHEEL UNIT - HYDRAULIC PIPING

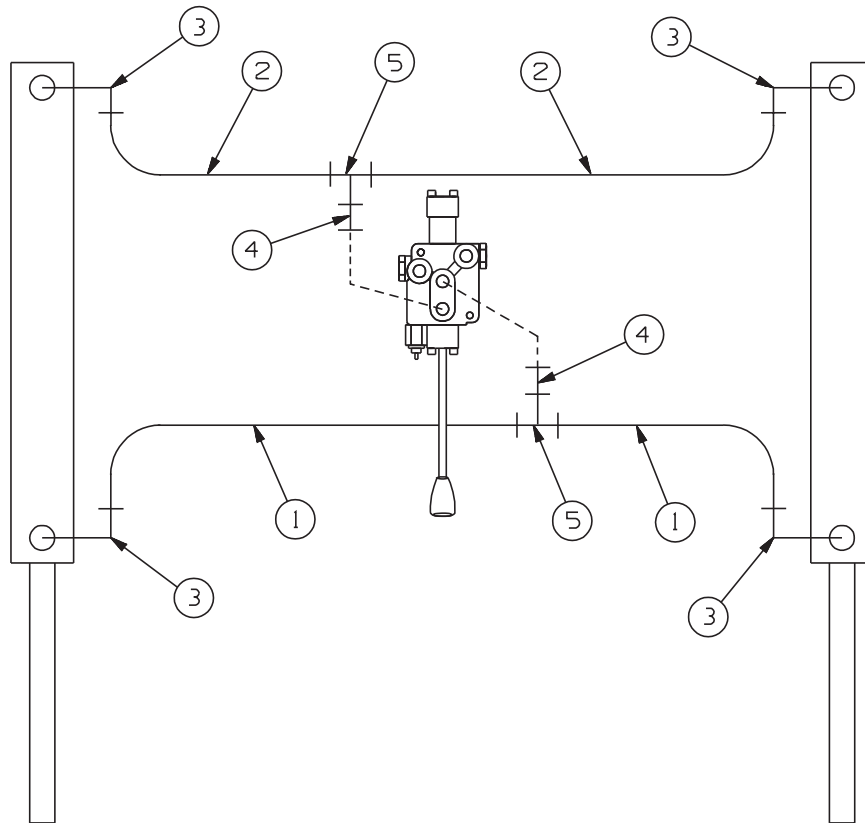

SE179194A-3

ITEM	PART NO	DESCRIPTION	QTY
1	188658	Hose, 5/16 x 29" Swivel 9/16 F JIC Both Ends	2
2	188661	Hose, 5/16 x 19" Swivel 9/16 F JIC Both Ends	2
3	F012055	90° Elbow, 9/16 M JIC x 3/8 M NPT.	4
4	F013518	Adapter.	2
5	F015626	Tee, 9/16 M JIC x 9/16 M JIC x 9/16 F STR	2

179546 GUIDE WHEEL UNIT - AIR BRAKE PIPING

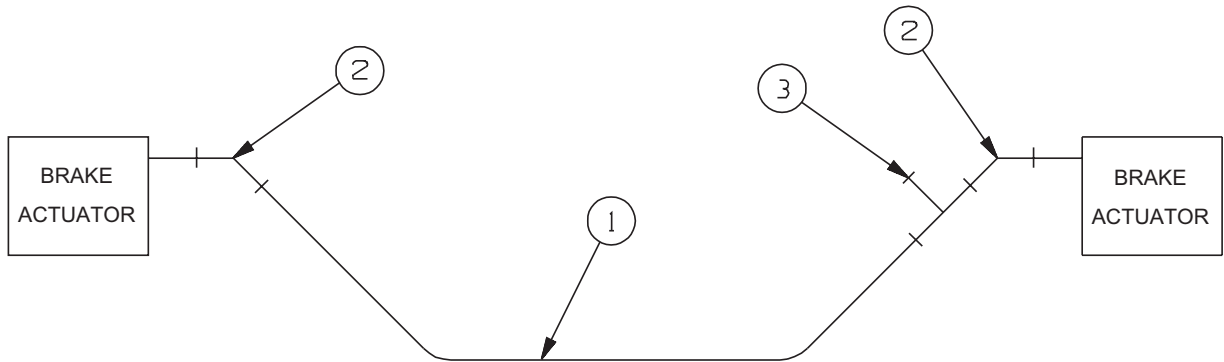

SE179546A-6

ITEM	PART NO	DESCRIPTION	QTY
1	188659	Hose, 5/16 x 78" Swivel 9/16 F JIC Both Ends	1
2	F018562	45° Elbow, 9/16 M JIC x 3/8 M NPT.	6
3	F013627	Tee	1

STEERING LOCK GROUPS

Individual steering lock components are not available as repair parts. Steering lock groups are sold as complete replacement groups only. See vehicle application charts to find the correct steering lock group applicable to your make, model and year of vehicle.

179557 RAIL SWEEP GROUP

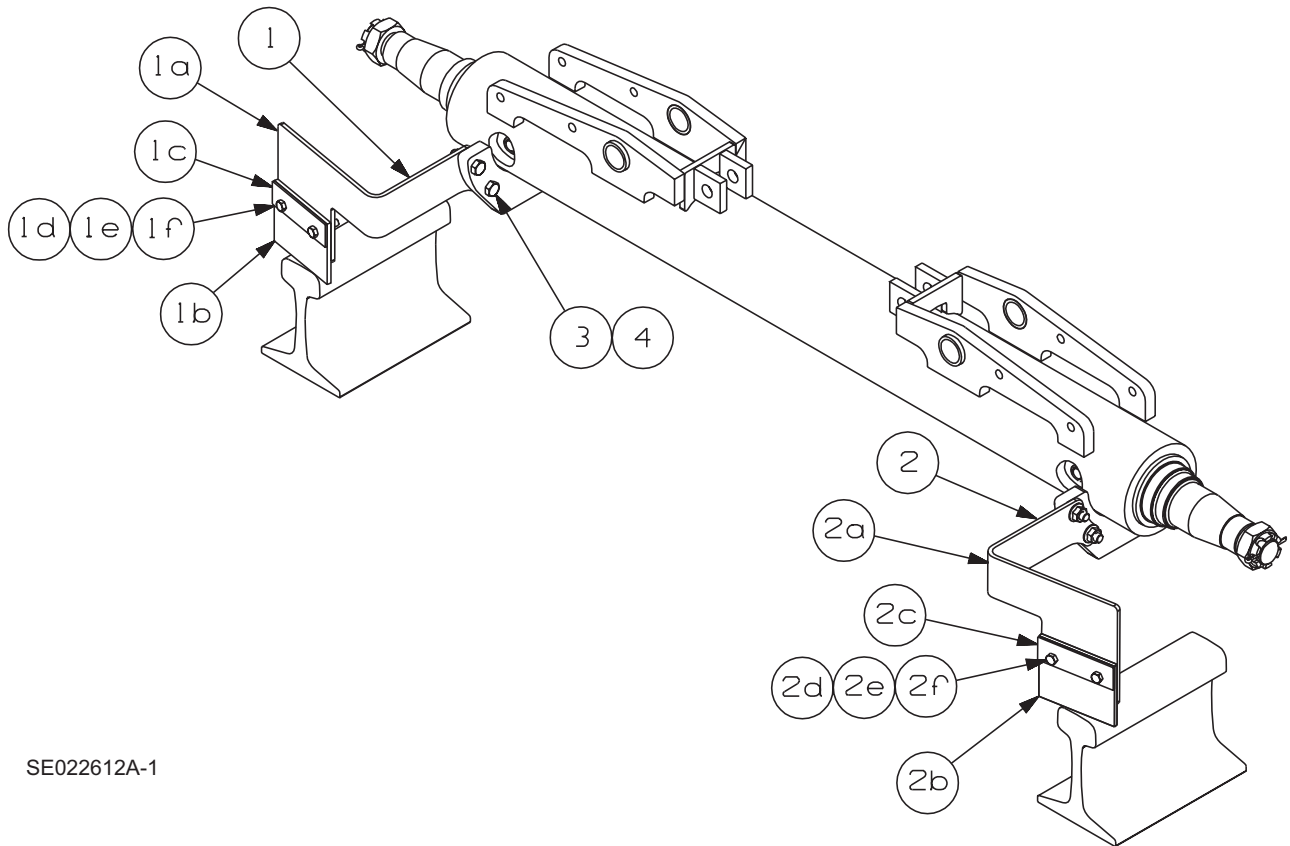

SE022612A-1

ITEM	PART NO	DESCRIPTION	QTY
1	179502	RAIL SWEEP ASSEMBLY,RIGHT.....	1
1a	179500	Rail Sweep Bracket	1
1b	108509K1	Rail Sweep	1
1c	108510	Bracket	1
1d	F015922	Hex Elastic Stop Nut, 3/8"-16	2
1e	F001024	Cap Screw, 3/8-16 x 1-1/2" Hex Hd	2
1f	F001115	Wrought Washer, 3/8".....	2
2	179503	RAIL SWEEP ASSEMBLY,LEFT.....	1
2a	179501	Rail Sweep Bracket	1
2b	108509K1	Rail Sweep	1
2c	108510	Bracket	1
2d	F015922	Hex Elastic Stop Nut, 3/8"-16	2
2e	F001024	Cap Screw, 3/8-16 x 1-1/2" Hex Hd	2
2f	F001115	Wrought Washer, 3/8".....	2
3	F001095	Cap Screw, 1/2-13 x 1-3/4" Hex Hd	6
4	F022037	Hex Flg Nut, 1/2"-13.....	6

154057 TRUCK BRAKE CONNECTION

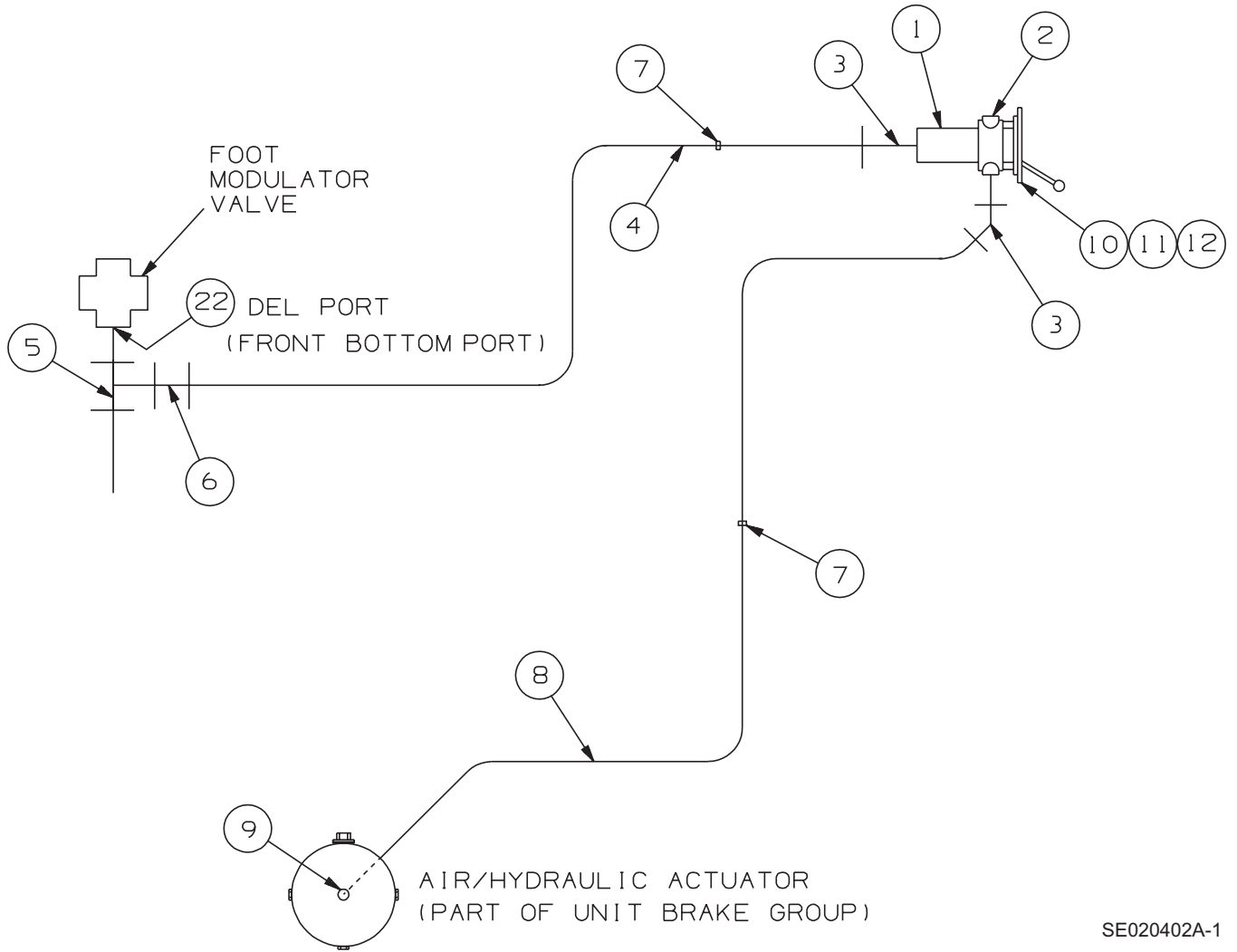

SE020402A-1

154057 TRUCK BRAKE CONNECTION

ITEM	PART NO	DESCRIPTION	QTY
	154057	TRUCK BRAKE CONNECTION	1
1	F019332	Air Control Valve.	1
2	F010989	Pipe Plug, 1/4 M NPT	1
3	F011117	45° Elbow, 9/16 M JIC x 1/4 M NPT	2
4	F018904	Hose, 5/16 x 48" Swivel 9/16 F JIC Both Ends.	1
5	F013684	Tee, 3/8 M NPT x 3/8 F NPT x 3/8 F NPT	1
6	F012056	Adapter, 9/16 M JIC x 3/8 M NPT.	1
7	F012587	Grommet.	2
8	154058	HOSE GROUP	1
8a	F010693	Hose, 5/16" I.D.	180"
8b	F011392	Swivel Hose Fitting, 9/16 F JIC	2
9	F010988	90° Elbow, 9/16 M JIC x 1/4 M NPT	1
10	122583	Instruction Plate, Rail Wheel... ..	1
11	F009591	Machine Screw, #10-24 x 3/4" Rd Hd.	2
12	120457	Decal, Rail Brake Operation... ..	1
13	120453	Bracket	1

162114 TRUCK BRAKE CONNECTION

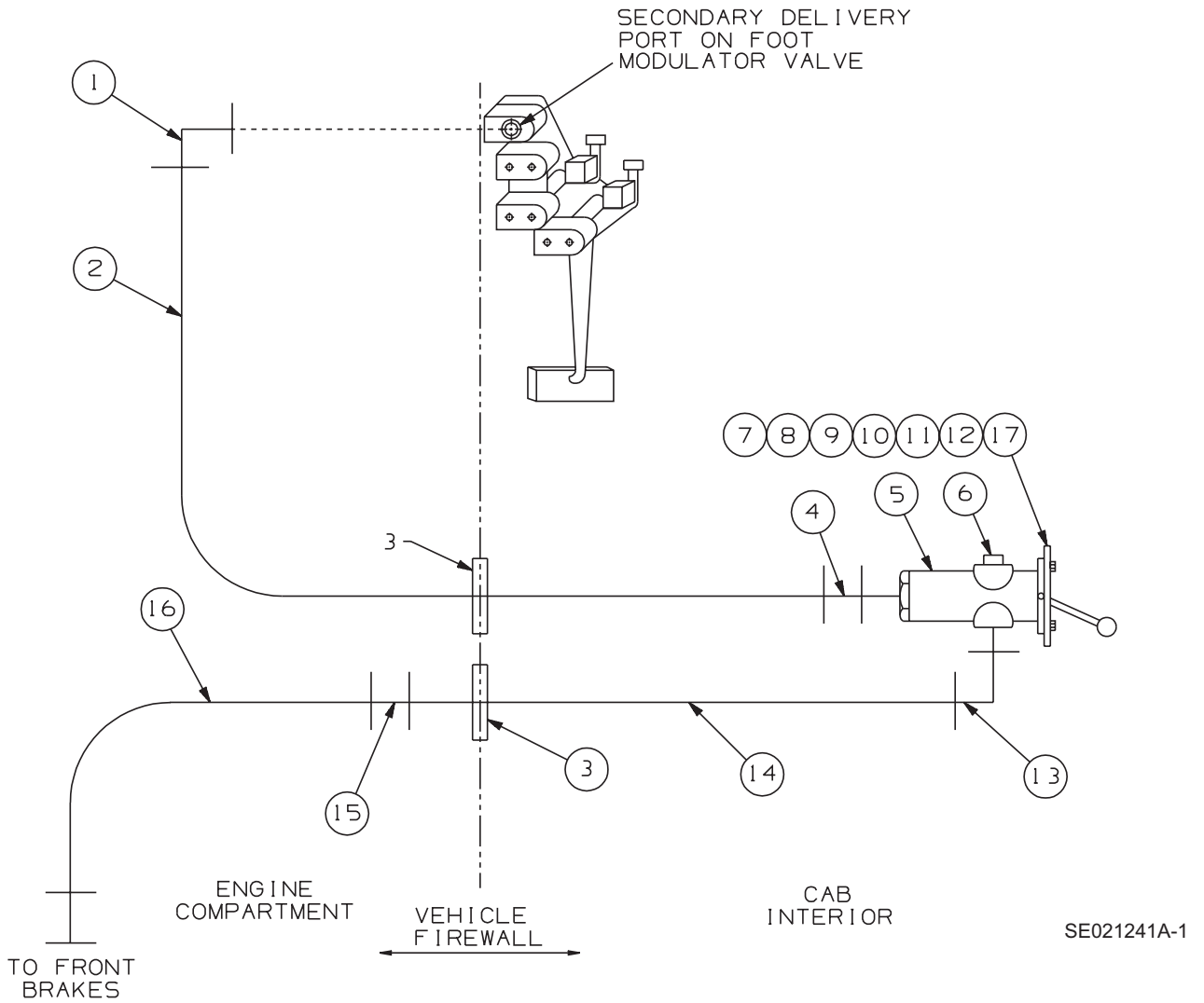

162114 TRUCK BRAKE CONNECTION

ITEM	PART NO	DESCRIPTION	QTY
	162114	TRUCK BRAKE CONNECTION	1
1	F012055	90° Elbow, 9/16 M JIC x 3/8 M NPT	1
2	F018904	Hose, 5/16 x 48" Swivel 9/16 F JIC Both Ends.	1
3	F012587	Grommet.	2
4	F010994	Adapter, 9/16 M JIC x 1/4 M NPT.	1
5	F019332	Air Control Valve.	1
6	F010989	Pipe Plug, 1/4 M NPT	1
7	120453	Bracket	1
8	F001113	Cap Screw, 5/16-18 x 1-1/4" Hex Hd	2
9	F001100	SAE Lock Washer, 5/16"	2
10	F007021	Hex Nut, 5/16"-18	2
11	122583	Instruction Plate, Rail Wheel...	1
12	F009591	Machine Screw, #10-24 x 3/4" Rd Hd.	2
13	F010988	90° Elbow, 9/16 M JIC x 1/4 M NPT	1
14	079235	Hose, 5/16 x 51" Swivel 9/16 F JIC Both Ends.	1
15	F011152	Adapter, 9/16 M JIC x 9/16 M JIC.	1
16	075540	Hose, 5/16 x 76" Swivel 9/16 F JIC Both Ends.	1
17	120457	Decal, Rail Brake Operation...	1

162130 TRUCK BRAKE CONNECTION

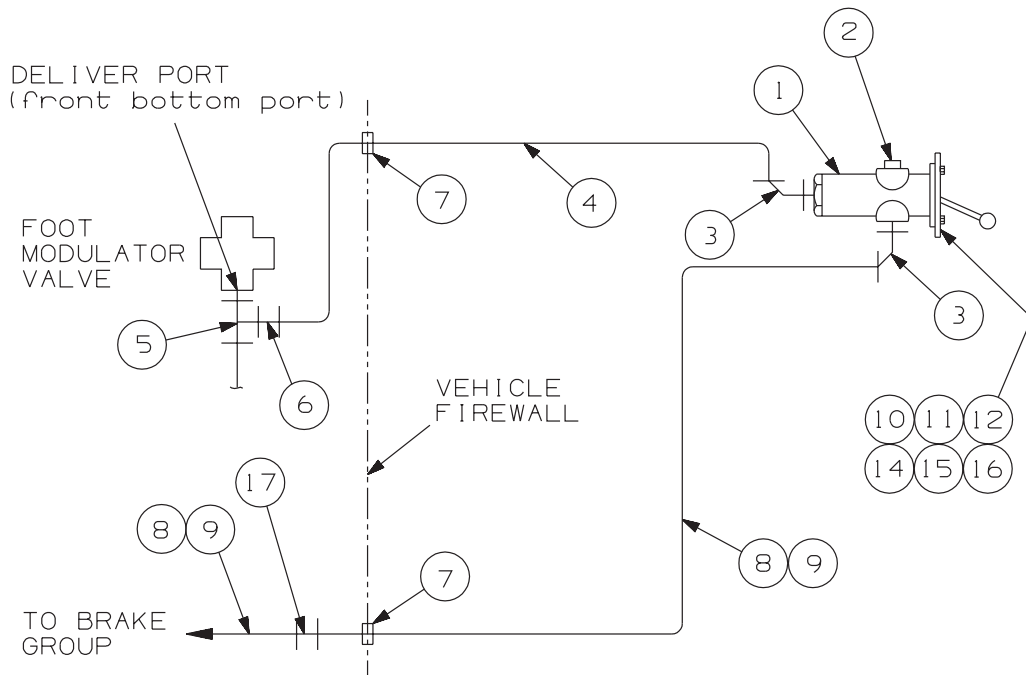

SE021238A-1

162130 TRUCK BRAKE CONNECTION

ITEM	PART NO	DESCRIPTION	QTY
	162130	TRUCK BRAKE CONNECTION	1
1	F019332	Control Valve	1
2	F010989	Pipe Plug, 1/4 M NPT	1
3	F011117	45° Elbow, 9/16 M JIC x 1/4 M NPT	2
4	F018904	Hose, 5/16 x 48" Swivel 9/16 F JIC Both Ends	1
5	F013684	Tee, 3/8 M NPT x 3/8 F NPT x 3/8 F NPT	1
6	F012056	Adapter, 9/16 M JIC x 3/8 M NPT	1
7	F012587	Grommet	2
	154058	HOSE GROUP	1
8	F010693	Hose, 5/16" I.D.	180"
9	F011392	Swivel Hose Fitting, 9/16 F JIC	4
10	120453	Bracket (control valve mounting)	1
11	122583	Instruction Plate - Rail Wheel Brakes ON/OFF	1
12	F009591	Machine Screw, #10-24 x 3/4" Rd Hd.	2
13	120457	Decal, Rail Brake Operation...(mount near control valve)	1
14	F001113	Cap Screw, 5/16-18 x 1-1/4" Hex Hd	2
15	F001100	SAE Lock Washer, 5/16"	2
16	F007021	Hex Nut, 5/16"-18	2
17	F011152	Adapter, 9/16 M JIC x 9/16-M JIC	1

179161 TRUCK BRAKE CONNECTION

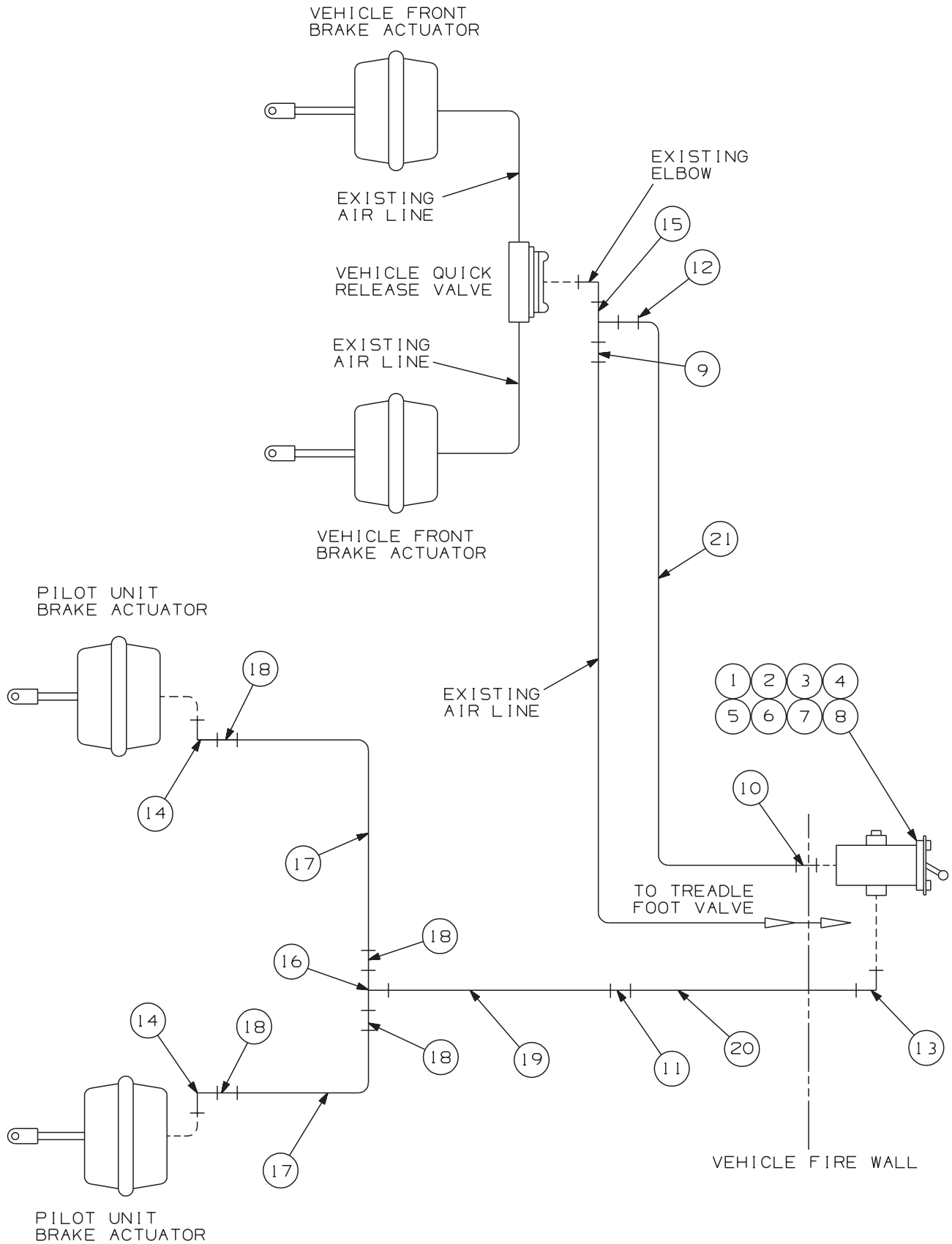

7

179161 TRUCK BRAKE CONNECTION

ITEM	PART NO	DESCRIPTION	QTY
	179161	TRUCK BRAKE CONNECTION	1
1	F019332	Air Control Valve.....	1
2	120453	Sheet	1
3	F001113	Cap Screw, 5/16-18 x 1-1/4" Hex Hd	2
4	F001100	SAE Lock Washer, 5/16"	2
5	F007021	Hex Nut, 5/16"-18	2
6	122583	Instruction Plate, Rail Wheel... ..	1
7	F009591	Machine Screw, #10-24 x 3/4" Rd Hd.	2
8	F010989	Pipe Plug, 1/4 M NPT	1
9	F011604	Hex Nipple, 3/8 M NPT x 3/8 M NPT	1
10	F010994	Adapter, 9/16 M JIC x 1/4 M NPT	1
11	F011152	Adapter, 9/16 M JIC x 9/16 M JIC	1
12	F012056	Adapter, 9/16 M JIC x 3/8 M NPT	1
13	F010988	90° Elbow, 9/16 M JIC x 1/4 M NPT	1
14	F012055	90° Elbow, 9/16 M JIC x 3/8 M NPT	1
15	F013459	Tee, 3/8 F NPT x 3/8 F NPT x 3/8 F NPT	1
16	F015626	Tee, 9/16 M JIC x 9/16 M JIC x 9/16 F STR	1
17	F010693	Hose, 5/16" I.D.	144"
18	F018064	Swivel Hose Fitting, 9/16 F JIC	4
19	075540	Hose, 5/16 x 76" Swivel 9/16 F JIC Both Ends	1
20	079235	Hose, 5/16 x 51" Swivel 9/16 F JIC Both Ends	1
21	160117	Hose, 5/16 x 104" Swivel 9/16 F JIC Both Ends	1
22	120457	Decal, Rail Brake Operation...(mount near control valve)	1

137926 HYDRAULIC POWER PACK - FULL

ITEM	PART NO	DESCRIPTION	QTY
	137926	HYDRAULIC POWER PACK -FULL	1
	129136	HYDRAULIC RESERVOIR ASSEMBLY	1
1	099444	Reservoir Only.	1
2	F014155	Filter	1
3	082205	Filter Flange	1
4	077997	Flange Gasket.	1
5	F001125	Cap Screw, 3/8-16 x 1-1/4" Hex Hd	4
6	F001025	SAE Lock Washer, 3/8"	4
7	F022655	FILLER CAP	1
8	F010465	Filler Screen	1
9	056780	Filler Flange Gasket	2
10	F010466	Filler Flange.	1
11	F009723	Machine Screw, 10-24 x 3/8" Rd Hd	6
12	F009541	SAE Lock Washer, #10	6
13	F010181	Drain Valve, 1/8 M NPT.	2
14	F012702	Pipe Plug, 3/8 M NPT Magnetic	1
15	F001328	Pipe Nipple, 3/4 M NPT x 1-3/8"	1
16	F015452	FILTER - RETURN	1
16a	F015453	Replacement Filter Element	1
17	120993	VALVE, FLOW DIVIDER.	1
17a	F019415	Pressure Relief Washers (set of four)	1
18	F009663	Cap Screw, 5/16-18 x 2" Hex Hd.	2
19	F007021	Hex Nut, 5/16"-18.	2
20	F001100	SAE Lock Washer, 5/16"	2
21	F001125	Cap Screw, 3/8-16 x 1-1/4" Hex Hd	4
22	F001025	SAE Lock Washer, 3/8"	4
23	F007020	Hex Nut, 3/8"-16	4
24	F023330	Hydraulic Pump	1
25	F003136	Cap Screw, 1/2-13 x 1" Hex Hd	2
26	F001075	SAE Lock Washer, 1/2"	2
	140344	HOSE GROUP	1
27	F009947	Hose, 13/32 x 960" (cut to length).	1
28	F020713	Hose Fitting, Swivel 3/4 F JIC (install on hose F009947)	8
29	F010298	Hose, 1-1/8 x 75" (cut to length)	1
30	F014307	Hose Fitting, Swivel 1-5/8 F JIC (install on hose F010298)	2
31	F013243	90° Elbow, 3/4 M NPT x 3/4 M JIC	1
32	F021260	90° Elbow, 1 M NPT x 1-5/8 M JIC	2
33	F012054	90° Elbow, 1/2 M NPT x 3/4 M JIC	2
34	F011114	90° Elbow, 3/8 M NPT x 3/4 M JIC	3
35	067736	Hose, 13/32 x 17" Swivel 3/4 F JIC Both Ends.	1
36	F011170	Adapter, 3/8 M NPT x 3/4 M JIC.	1
37	F012704	90° Elbow, 3/4 M JIC x 3/8 M NPT	1

137926 HYDRAULIC POWER PACK - FULL

ITEM	PART NO	DESCRIPTION	QTY
38	F013605	Tee, 3/4 M JIC x 3/8 M NPT x 3/8 M NPT	1
39	F015303K	Nose Piece, 3/8 F NPT	2
40	F015077	Dust Cap.	2
41	F014722	Tee, 3/8 F NPT x 3/4 M JIC x 3/8 M NPT	1
42	F011604	Adapter, 3/8 M NPT x 3/8 M NPT	1
43	F013629	Tee, 3/4 M JIC x 3/4 M JIC x 3/8 M NPT	1
44	F012024	Reducer Bushing, 3/4 M NPT x 3/8 F NPT	1
45	067736	Hose, 13/32 x 17" Swivel 3/4 F JIC Both Ends	1
47	F011617	Reducer Bushing, 1 M NPT x 3/4 F NPT	1
	099137K	PRESSURE GAUGE ASSEMBLY	1
48	F015110K	Body, 3/8 F NPT	1
49	F015111	Dust Cap	1
50	F012056	Adapter, 3/8 M NPT x 9/16 M JIC	1
51	171878	Hose, 3/8 x 14" Swivel 9/16 F JIC Both Ends	1
52	F011109	Adapter, 9/16 M JIC x 1/4 F NPT	1
53	F011432K	Pressure Gauge, 1/4 M NPT	1
54	137941	Decal, Caution -Recommended....	1
55	F015103	Adapter, 3/8 F NPT x 3/4 M STR (used on vertical units only).	2

137927 HYDRAULIC POWER PACK - ABBREVIATED

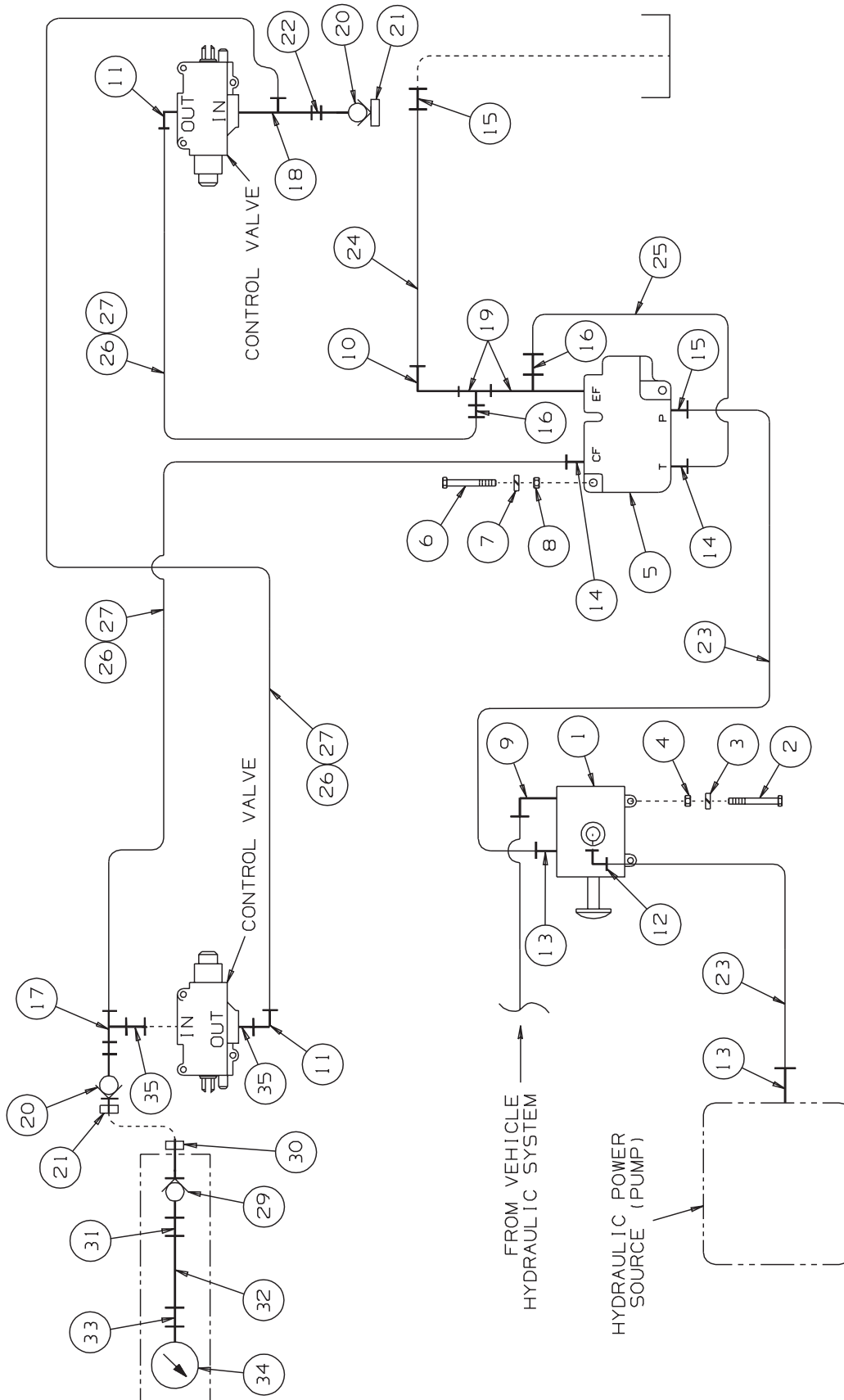

137927 HYDRAULIC POWER PACK - ABBREVIATED

ITEM	PART NO	DESCRIPTION	QTY
	137927	HYDRAULIC POWER PACK -ABBREVIATED	1
1	F016490	Selector Valve	1
2	F002760	Cap Screw, 3/8-16 x 2-1/4" Hex Hd	2
3	F001025	SAE Lock Washer, 3/8"	2
4	F009670	Hex Grip Nut, 3/8"-16	2
5	120993	VALVE, FLOW DIVIDER	1
	F019415	Pressure Relief Washers (set of four)	1
6	F009663	Cap Screw, 5/16-18 x 2" Hex Hd	2
7	F001100	SAE Lock Washer, 5/16"	2
8	F007021	Hex Nut, 5/16"-18	2
9	F012010	90° Elbow Street, 3/4 F NPT x 3/4 M NPT	1
10	F010584	90° Elbow, 1-1/16 M JIC x 1/2 M NPT	1
11	F011114	90° Elbow, 3/4 M JIC x 3/8 M NPT	2
12	F010586	90° Elbow, 1-1/16 M JIC x 3/4 M NPT	1
13	F010581	Adapter, 1-1/16 M JIC x 3/4 M NPT	2
14	F011170	Adapter, 3/4 M JIC x 3/8 M NPT	2
15	F013210	Adapter, 1-1/16 M JIC x 1/2 M NPT	2
16	F012027	Adapter, 3/4 M JIC x 1/2 M NPT	2
17	F013605	Tee, 3/4 M JIC x 3/8 M NPT x 3/8 M NPT	1
18	F014722	Tee, 3/8 F NPT x 3/4 M JIC x 3/8 M NPT	1
19	F010692	Tee, 1/2 F NPT x 1/2 M NPT x 1/2 F NPT	2
20	F015303K	Nose Piece, 3/8 F NPT	2
21	F015077	Dust Cap	2
22	F011604	Adapter, 3/8 M NPT x 3/8 M NPT	1
23	071692	Hose, 5/16 x 48" Swivel 1-1/16 F JIC Both Ends	2
24	111100	Hose, 3/4 x 28" Swivel 1-1/16 F JIC Both Ends	1
25	071867	Hose, 1/2 x 19-3/4" Swivel 3/4 F JIC Both Ends	1
	140345	HOSE GROUP	1
26	F009947	Hose, 13/32 x 960" (cut to length)	1
27	F020713	Hose Fitting, Swivel 3/4 F JIC (install on hose F009947)	6
	099137K	PRESSURE GAUGE ASSEMBLY	1
29	F015110K	Body, 3/8 F NPT	1
30	F015111	Dust Cap	1
31	F012056	Adapter, 3/8 M NPT x 9/16 M JIC	1
32	171878	Hose, 3/8 x 14" Swivel 9/16 F JIC Both Ends	1
33	F011109	Adapter, 9/16 M JIC x 1/4 F NPT	1
34	F011432K	Pressure Gauge, 1/4 M NPT	1
35	F015103	Adapter, 3/8 F NPT x 3/4 M STR (used on vertical units only)	2

164574 SIGHT ROD EXTENSION GROUP

PART NO	DESCRIPTION	QTY
164574	SIGHT ROD EXTENSION GROUP	1
130195	Sight Rod Kit (includes two sight rods)	1
135809	Sight Rod Extension	2
161855	Mounting Bar	2
F022036	Cap Screw, 1/2-13 x 1-1/4" Hex Flg Hd	2
F022037	Hex Flg Nut, 1/2"-13	2

180781 DECAL SERVICE GROUP

PART NO	DESCRIPTION	QTY
180781	DECAL SERVICE GROUP	1
F018082	Decal, Safety Instructions: Lock Front Wheels...	1
F018083	Decal, Axle Lock Instructions	2
140220	Decal, Warning: Do Not Operate...	2
155007	Decal, HY-RAIL® Vehicle Completed By...	1
157230	Decal, Safety Instructions	1
179152	Decal, Operating Instructions	2
179485	Decal, Operating Instructions	1
179521	Decal, Axle Lock Instructions	2
179522	Decal, Axle Lock Instructions	2
163187	Decal, Axle Lock Instructions	2
184073	Decal, Control Valve Operating Instructions	1
191761	Decal, Harsco Track Technologies	1

179139 MOUNTING BRACKET GROUP

PART NO	DESCRIPTION	QTY
179139	MOUNTING BRACKET GROUP	1
181587	Shim (use as required)	4
F021243	Cap Screw, 3/4-10 x 3" Hex Hd	8
F021137	Hardened Washer.	8
F013633	Elastic Stop Nut, 3/4"-10	8
126411	Bracket	2
130457	Axle Hook	2
130620	Rod	1
130621	Rod	1
169562	Hook Arm	2
169563	Axle Hook	2
179191	Bar (weld on)	2
184160	Axle Hook Bracket, Right	1
184162	Axle Hook Bracket, Left	1
186133	Hook Arm	2
F001104	Cotter Pin, 1/8 x 1"	2
F001267	Wrought Washer, 1/2".	2
F001354	SAE Lock Washer, 3/4"	4
F001547	Cotter Pin, 1/4 x 2"	2
F007022	Hex Nut, 1/4"-20	4
F009825	Cap Screw, 1/4-20 x 1" Hex Hd	4
F009535	SAE Lock Washer, 1/4"	4
F011954	Spring Pin, 3/8 x 1-1/2".	4
F012452	Elastic Stop Nut, 5/8"	6
F013412	Wrought Washer, 1"	2
F013633	Elastic Stop Nut, 3/4"-10	4
F014260K	Knob	2
F019501	Cap Screw, 5/8-11 x 1-3/4" Hex Hd	4
F020458	Cap Screw, 3/4-10 x 2-1/2" GR 8 Hex Hd	6
F020598	Spring	2
F020964	Collar	2
F023012	Hardened Washer.	12
F023743	Cap Screw, 5/8-11 x 5-1/2" GR 8 Hex Hd	6
M022821	Side Step	2
022573	Front Unit Application Drawing	

179543 MOUNTING BRACKET GROUP

PART NO	DESCRIPTION	QTY
179543	MOUNTING BRACKET GROUP	1
181587	Shim (use as required)	4
F021243	Cap Screw, 3/4-10 x 3" Hex Hd	8
F021137	Hardened Washer.	8
F013633	Elastic Stop Nut, 3/4"-10	8
125789	Rod	2
126411	Bracket	2
130457	Axle Hook	2
130458	Hook Arm	2
179191	Bar (weld on)	2
186196	Axle Hook Bracket	2
F001104	Cotter Pin, 1/8 x 1"	2
F001267	Wrought Washer, 1/2".	2
F001753	Wrought Washer, 3/4".	2
F007022	Hex Nut, 1/4"-20	4
F009535	SAE Lock Washer, 1/4"	4
F009825	Cap Screw, 1/4-20 x 1" Hex Hd	4
F011954	Spring Pin, 3/8 x 1-1/2".	4
F012452	Elastic Stop Nut, 5/8"	10
F013633	Elastic Stop Nut, 3/4"-10	2
F014260K	Knob	2
F019501	Cap Screw, 5/8-11 x 1-3/4" Hex Hd	4
F020598	Spring	2
F020964	Collar	2
F021243	Cap Screw, 3/4-10 x 3" Hex Hd	2
F023743	Cap Screw, 5/8-11 x 5-1/2" GR 8 Hex Hd	6
M022621	Spacer	2
022534	Front Unit Application Drawing (International 4900)	
023189	Front Unit Application Drawing (International 2674)	

179544 MOUNTING BRACKET GROUP

PART NO	DESCRIPTION	QTY
179544	MOUNTING BRACKET GROUP	1
181587	Shim (use as required)	4
F021243	Cap Screw, 3/4-10 x 3" Hex Hd	8
F021137	Hardened Washer	8
F013633	Elastic Stop Nut, 3/4"-10	8
125789	Rod	2
126411	Bracket	2
154505	Axle Hook Bracket	1
154508	Axle Hook Bracket	1
158188	Bumper Bracket	2
169563	Axle Hook	2
179191	Bar (weld on)	2
179545	Mounting Plate	2
179914	Spacer	2
186113	Axle Hook	2
F001104	Cotter Pin, 1/8 x 1"	2
F001267	Wrought Washer, 1/2"	2
F001753	Wrought Washer, 3/4"	36
F007022	Hex Nut, 1/4"-20	4
F009535	SAE Lock Washer, 1/4"	4
F009825	Cap Screw, 1/4-20 x 1" Hex Hd	4
F011954	Spring Pin, 3/8 x 1-1/2"	4
F012452	Elastic Stop Nut, 5/8"	20
F013633	Elastic Stop Nut, 3/4"-10	20
F014260K	Knob	2
F019501	Cap Screw, 5/8-11 x 1-3/4" Hex Hd	4
F020458	Cap Screw, 3/4-10 x 2-1/2" Hex Hd	12
F020598	Spring	2
F020964	Collar	2
F023743	Cap Screw, 5/8-11 x 5-1/2" GR 8 Hex Hd	6
M022621	Spacer	2
022569	Front Unit Application Drawing	

179948 MOUNTING BRACKET GROUP

PART NO	DESCRIPTION	QTY
179948	MOUNTING BRACKET GROUP	1
181587	Shim (use as required)	4
F021243	Cap Screw, 3/4-10 x 3" Hex Hd	8
F021137	Hardened Washer.	8
F013633	Elastic Stop Nut, 3/4"-10	8
130620	Rod	1
130621	Rod	1
169562	Hook Arm	2
169563	Axle Hook	2
179931	Axle Hook Bracket, Left	1
179932	Axle Hook Bracket, Right	1
179995	Side Bar, Left	1
179996	Side Bar, Right	1
700568225	Cap Screw, 3/4-10 x 2-1/4" Hex Hd	8
700666075	Hex Lock Nut, 3/4"-10.	24
F001104	Cotter Pin, 1/8 x 1"	2
F001267	Wrought Washer, 1/2".	2
F001354	SAE Lock Washer, 3/4"	4
F001547	Cotter Pin, 1/4 x 2"	2
F006382	Cap Screw, 3/4-10 x 2-1/2" Hex Hd	14
F011954	Spring Pin, 3/8 x 1-1/2".	4
F013412	Wrought Washer, 1"	2
F014260K	Knob	2
F015807	Cap Screw, 5/8-18 x 1-3/4" Hex Hd	4
F020598	Spring	2
F020917	Hex Flg Nut, 5/8"-18	4
F020964	Collar	2
F021137	Hardened Washer.	8
F026075	Cap Screw, 3/4-10 x 6" Hex Hd	2
022614	Front Unit Application Drawing	

184159 MOUNTING BRACKET GROUP

PART NO	DESCRIPTION	QTY
184159	MOUNTING BRACKET GROUP	1
181587	Shim (use as required)	4
F021243	Cap Screw, 3/4-10 x 3" Hex Hd	8
F021137	Hardened Washer.	8
F013633	Elastic Stop Nut, 3/4"-10	8
125789	Rod	2
126411	Bracket	2
130457	Hook	2
179191	Bar	2
184160	Axle Hook Bracket, Right	1
184162	Axle Hook Bracket, Left	1
186112	Spacer	2
186113	Hook Arm	2
700562325	Cap Screw, 3/8-16 x 3-1/4" GR 8 Hex Hd	8
F001104	Cotter Pin, 1/8 x 1"	2
F001106	Wrought Washer, 1/4".	8
F001267	Wrought Washer, 1/2".	2
F001753	Wrought Washer, 3/4".	2
F006199	Cap Screw, 1/4-20 x 4-1/2" GR 5 Hex Hd	4
F007022	Hex Nut, 1/4"-20 GR 5	8
F009535	SAE Lock Washer, 1/4"	8
F009825	Cap Screw, 1/4-20 x 1" GR 5 Hex Hd.	4
F011954	Spring Pin, 3/8 x 1-1/2".	4
F012452	Elastic Stop Nut, 5/8"	10
F013633	Elastic Stop Nut, 3/4"-10	2
F014260K	Semi Ball Handle	2
F019501	Cap Screw, 5/8-11 x 1-3/4" Hex Hd	4
F020598	Spring	2
F020964	Collar	2
F021243	Cap Screw, 3/4-10 x 3" Hex Hd	2
F023743	Cap Screw, 5/8-11 x 5-1/2" GR 8 Hex Hd	6
M022621	Spacer	2
022999	Front Unit Application Drawing	

184170 MOUNTING BRACKET GROUP

PART NO	DESCRIPTION	QTY
184170	MOUNTING BRACKET GROUP	1
181587	Shim (use as required)	4
F021243	Cap Screw, 3/4-10 x 3" Hex Hd	8
F021137	Hardened Washer.	8
F013633	Elastic Stop Nut, 3/4"-10	8
130620	Rod	1
130621	Rod	1
149966	Cap Screw, 5/8-11 x 2-1/2" GR 8 Hex Hd	1
169562	Plate	2
169563	Plate	2
179191	Bar	2
179488	Bar	2
184148	Bracket, Left	1
184149	Bracket, Right	1
184153	Side Bar, Right	1
184154	Side Bar, Left	1
F001075	SAE Lock Washer, 1/2"	6
F001104	Cotter Pin, 1/8 x 1"	4
F001267	Wrought Washer, 1/2".	4
F001753	Wrought Washer, 3/4".	4
F003598	Hex Nut, 1/2"-13 GR 5	6
F005192	Cap Screw, 5/8-11 x 1-3/4" GR 5 Hex Hd	8
F007022	Hex Nut, 1/4"-20 GR 5	4
F009425	SAE Washer, 5/8".	6
F009535	Lock Washer, 1/4".	4
F009825	Cap Screw, 1/4-20 x 1" GR 5 Hex Hd.	4
F011954	Spring Pin, 3/8 x 1-1/2".	4
F014260K	Semi Ball Handle	2
F016378	Cap Screw, 5/8-11 x 3-1/2" GR 8 Hex Hd	8
F018599	Cap Screw, 1/2-13 x 5" GR 5 Hex Hd.	6
F020458	Cap Screw, 3/4-10 x 2-1/2" GR 8 Hex Hd	2
F020598	Spring	2
F020964	Collar	2
F021137	Hardened Washer.	10
F023375	Hex Flg Nut, 3/4"-10 GR 8	2
F025425	Hex Lock Nut, 5/8"-11.	17
M022621	Pivot Plate Spacer	2
022984	Front Unit Application Drawing	

193979 MOUNTING BRACKET GROUP

PART NO	DESCRIPTION	QTY
193979	MOUNTING BRACKET GROUP	1
181587	Shim (use as required)	4
F021243	Cap Screw, 3/4-10 x 3" Hex Hd	8
F021137	Hardened Washer.	8
F013633	Elastic Stop Nut, 3/4"-10	8
126411	Bracket	1
145446	Elastic Stop Nut, 1"-8	2
179191	Bar	2
186113	Hook Arm	2
188894	Cap Screw, 1/2-13 x 7" GR 8 Hex Hd.	2
193955	Spacer	2
193983	Cap Screw, 3/4-10 x 7" GR 8 Hex Hd.	8
196512	Axle Bracket, Left	1
196513	Axle Bracket, Right	1
196516	Pull Rod	1
196517	Axle Hook	2
051161308	Hardened Washer.	4
700571700	Cap Screw, 1-8 x 7" GR 8 Hex Hd	2
F001104	Cotter Pin, 1/8 x 1"	2
F001267	Wrought Washer, 1/2".	4
F001547	Cotter Pin, 1/4 x 2"	2
F007022	Hex Nut, 1/4"-20 GR 5	2
F009535	Lock Washer, 1/4".	4
F009825	Cap Screw, 1/4-20 x 1" GR 5 Hex Hd.	4
F011954	Spring Pin, 3/8 x 1-1/2".	2
F012452	Elastic Stop Nut, 5/8"	4
F013500	Elastic Stop Nut, 1/2"	2
F013695	Hex Nut, 3/4"-10 GR 5	2
F014260K	Semi Ball Handle	1
F015807	Cap Screw, 5/8-18 x 1-3/4" Hex Hd	4
F020458	Cap Screw, 3/4-10 x 2-1/2" GR 8 Hex Hd	2
F020598	Spring	1
F020917	Hex Flg Nut, 5/8"-18	4
F020964	Collar	1
F021137	Hardened Washer.	16
F023012	Hardened Washer.	8
F023743	Cap Screw, 5/8-11 x 5-1/2" GR 8 Hex Hd	4
F024047	Washer	4
M022621	Pivot Plate Spacer	2
023842	Front Unit Application Drawing	

SECTION 8 - VEHICLE APPLICATIONS
TABLE OF CONTENTS

1998 CHEVROLET / GMC	8 - 2
1999 CHEVROLET / GMC	8 - 2
2000 CHEVROLET / GMC	8 - 3
2001 CHEVROLET / GMC	8 - 3
2002 CHEVROLET / GMC	8 - 4
1998 FORD	8 - 5
1998 FREIGHTLINER	8 - 6
1999 FREIGHTLINER	8 - 7
2000 FREIGHTLINER	8 - 8
2001 FREIGHTLINER	8 - 9
2002 FREIGHTLINER	8 - 10
1998 INTERNATIONAL	8 - 11
1999 INTERNATIONAL	8 - 12
2000 INTERNATIONAL	8 - 14
2001 INTERNATIONAL	8 - 16
2002 INTERNATIONAL	8 - 18
1999 STERLING	8 - 20
2000 STERLING	8 - 21
2001 STERLING	8 - 22
2002 STERLING	8 - 23
2001 VOLVO WHITE GMC	8 - 24
2002 VOLVO WHITE GMC	8 - 24

1998 CHEV/GMC C7H042 14,600 GAWR FRONT AXLE HR4000V1 FRONT HR4000A2 REAR	1999 CHEV/GMC C7H042 14,600 GAWR FRONT AXLE HR4000V1 FRONT HR4000A2 REAR
---	---

REQUIRED GROUPS

Front Guide Wheel Unit	179546	179546
Mounting Brackets	184170	184170
Steering Lock	155079	155079
Application Drawing - Front	022984	022984

ACCESSORY GROUP OPTIONS

* Rail Sweeps	179557	179557
Truck Brake Connection.	154057	154057
Hydraulic Power Pack - Full.	137926	137926
Hydraulic Power Pack - Abbreviated	137927	137927
Sight Rod Kit And Extension	164574	164574

* Recommended Safety Option

2000 CHEV/GMC C7H042 14,600 GAWR FRONT AXLE HR4000V1 FRONT HR4000A2 REAR	2001 CHEV/GMC C7H042 14,600 GAWR FRONT AXLE HR4000V1 FRONT HR4000A2 REAR
---	---

REQUIRED GROUPS

Front Guide Wheel Unit	179546	179546
Mounting Brackets	184170	184170
Steering Lock	155079	155079
Application Drawing - Front	022984	022984

ACCESSORY GROUP OPTIONS

* Rail Sweeps	179557	179557
Truck Brake Connection.	154057	154057
Hydraulic Power Pack - Full.	137926	137926
Hydraulic Power Pack - Abbreviated	137927	137927
Sight Rod Kit And Extension	164574	164574

* Recommended Safety Option

2002 CHEV/GMC
C7H042
14,600 GAWR
FRONT AXLE
HR4000V1 FRONT
HR4000A2 REAR

REQUIRED GROUPS

Front Guide Wheel Unit	179546
Mounting Brackets	184170
Steering Lock	155079
Application Drawing - Front	022984

ACCESSORY GROUP OPTIONS

- * Rail Sweeps 179557
 - Truck Brake Connection. 154057
 - Hydraulic Power Pack - Full. 137926
 - Hydraulic Power Pack - Abbreviated 137927
 - Sight Rod Kit And Extension 164574
- * Recommended Safety Option

1998 FORD	1998 FORD
LT-8501	LT-8501
16,000 GAWR	16,000 GAWR
FRONT AXLE	FRONT AXLE
WITH FRONT	WITHOUT FRONT
FRAME EXTENSION	FRAME EXTENSION
HR4000V1 FRONT	HR4000V1 FRONT
HR4000A2 REAR	HR4000A2 REAR

REQUIRED GROUPS

Front Guide Wheel Unit	179546	179546
Mounting Brackets	179139	179948
Steering Lock	179140	179140
Application Drawing - Front	022573	022614

ACCESSORY GROUP OPTIONS

* Rail Sweeps	179557	179557
Truck Brake Connection.	179161	179161
Hydraulic Power Pack - Full	137926	137926
Hydraulic Power Pack - Abbreviated	137927	137927
Sight Rod Kit And Extension	164574	164574
* Recommended Safety Option		

1998 FRIEGHTLINER FL80 14,600 GAWR FRONT AXLE HR4000V1 FRONT HR4000A2 REAR	1998 FRIEGHTLINER FL80 16,000 GAWR FRONT AXLE HR4000V1 FRONT HR4000A2 REAR
---	---

REQUIRED GROUPS

Front Guide Wheel Unit	179546	179546
Mounting Brackets	184159	184159
Steering Lock	168053	168053
Application Drawing - Front	022999	022999

ACCESSORY GROUP OPTIONS

* Rail Sweeps	179557	179557
Truck Brake Connection.	179161	179161
Hydraulic Power Pack - Full.	137926	137926
Hydraulic Power Pack - Abbreviated	137927	137927
Sight Rod Kit And Extension	164574	164574

* Recommended Safety Option

1999 FRIEGHTLINER FL80 14,600 GAWR FRONT AXLE HR4000V1 FRONT HR4000A2 REAR	1999 FRIEGHTLINER FL80 16,000 GAWR FRONT AXLE HR4000V1 FRONT HR4000A2 REAR
---	---

REQUIRED GROUPS

Front Guide Wheel Unit	179546	179546
Mounting Brackets	184159	184159
Steering Lock	168053	168053
Application Drawing - Front	022999	022999

ACCESSORY GROUP OPTIONS

* Rail Sweeps	179557	179557
Truck Brake Connection.	179161	179161
Hydraulic Power Pack - Full.	137926	137926
Hydraulic Power Pack - Abbreviated	137927	137927
Sight Rod Kit And Extension	164574	164574

* Recommended Safety Option

2000 FRIEGHTLINER FL80 14,600 GAWR FRONT AXLE HR4000V1 FRONT HR4000A2 REAR	2000 FRIEGHTLINER FL80 16,000 GAWR FRONT AXLE HR4000V1 FRONT HR4000A2 REAR
---	---

REQUIRED GROUPS

Front Guide Wheel Unit	179546	179546
Mounting Brackets	184159	184159
Steering Lock	168053	168053
Application Drawing - Front	022999	022999

ACCESSORY GROUP OPTIONS

* Rail Sweeps	179557	179557
Truck Brake Connection.	179161	179161
Hydraulic Power Pack - Full.	137926	137926
Hydraulic Power Pack - Abbreviated	137927	137927
Sight Rod Kit And Extension	164574	164574

* Recommended Safety Option

2001 FRIEGHTLINER FL80 14,600 GAWR FRONT AXLE HR4000V1 FRONT HR4000A2 REAR	2001 FRIEGHTLINER FL80 16,000 GAWR FRONT AXLE HR4000V1 FRONT HR4000A2 REAR
---	---

REQUIRED GROUPS

Front Guide Wheel Unit	179546	179546
Mounting Brackets	184159	184159
Steering Lock	168053	168053
Application Drawing - Front	022999	022999

ACCESSORY GROUP OPTIONS

* Rail Sweeps	179557	179557
Truck Brake Connection.	179161	179161
Hydraulic Power Pack - Full.	137926	137926
Hydraulic Power Pack - Abbreviated	137927	137927
Sight Rod Kit And Extension	164574	164574

* Recommended Safety Option

2002 FRIEGHTLINER FL80 14,600 GAWR FRONT AXLE HR4000V1 FRONT HR4000A2 REAR	2002 FRIEGHTLINER FL80 16,000 GAWR FRONT AXLE HR4000V1 FRONT HR4000A2 REAR
---	---

REQUIRED GROUPS

Front Guide Wheel Unit	179546	179546
Mounting Brackets	184159	184159
Steering Lock	168053	168053
Application Drawing - Front	022999	022999

ACCESSORY GROUP OPTIONS

* Rail Sweeps	179557	179557
Truck Brake Connection.	179161	179161
Hydraulic Power Pack - Full.	137926	137926
Hydraulic Power Pack - Abbreviated	137927	137927
Sight Rod Kit And Extension	164574	164574

* Recommended Safety Option

1998 INTERNATIONAL 4900 16,000 GAWR FRONT AXLE WITH FRONT FRAME EXTENSION HR4000V1 FRONT HR4000A2 REAR	1998 INTERNATIONAL 4900 16,000 GAWR FRONT AXLE WITHOUT FRONT FRAME EXTENSION HR4000V1 FRONT HR4000A2 REAR
---	--

REQUIRED GROUPS

Front Guide Wheel Unit	179546	179546
Mounting Brackets	179543	179544
Steering Lock	154512	154512
Application Drawing - Front	022534	022569

ACCESSORY GROUP OPTIONS

* Rail Sweeps	179557	179557
Truck Brake Connection.	162114	162114
Hydraulic Power Pack - Full	137926	137926
Hydraulic Power Pack - Abbreviated	137927	137927
Sight Rod Kit And Extension	164574	164574
* Recommended Safety Option		

1999 INTERNATIONAL
2674
16,000 GAWR
FRONT AXLE
WITH FRONT
FRAME EXTENSION
HR4000V1 FRONT
HR4000A2 REAR

REQUIRED GROUPS

Front Guide Wheel Unit	179546
Mounting Brackets	179543
Steering Lock	186205
Application Drawing - Front	023189

ACCESSORY GROUP OPTIONS

- * Rail Sweeps 179557
 - Truck Brake Connection. 162114
 - Hydraulic Power Pack - Full 137926
 - Hydraulic Power Pack - Abbreviated 137927
 - Sight Rod Kit And Extension 164574
- * Recommended Safety Option

1999 INTERNATIONAL 4900 16,000 GAWR FRONT AXLE WITH FRONT FRAME EXTENSION HR4000V1 FRONT HR4000A2 REAR	1999 INTERNATIONAL 4900 16,000 GAWR FRONT AXLE WITHOUT FRONT FRAME EXTENSION HR4000V1 FRONT HR4000A2 REAR
---	--

REQUIRED GROUPS

Front Guide Wheel Unit	179546	179546
Mounting Brackets	179543	179544
Steering Lock	186205	186205
Application Drawing - Front	022534	022569

ACCESSORY GROUP OPTIONS

* Rail Sweeps	179557	179557
Truck Brake Connection.	162114	162114
Hydraulic Power Pack - Full	137926	137926
Hydraulic Power Pack - Abbreviated	137927	137927
Sight Rod Kit And Extension	164574	164574
* Recommended Safety Option		

2000 INTERNATIONAL
2674
16,000 GAWR
FRONT AXLE
WITH FRONT
FRAME EXTENSION
HR4000V1 FRONT
HR4000A2 REAR

REQUIRED GROUPS

Front Guide Wheel Unit	179546
Mounting Brackets	179543
Steering Lock	186205
Application Drawing - Front	023189

ACCESSORY GROUP OPTIONS

- * Rail Sweeps 179557
 - Truck Brake Connection. 162114
 - Hydraulic Power Pack - Full 137926
 - Hydraulic Power Pack - Abbreviated 137927
 - Sight Rod Kit And Extension 164574
- * Recommended Safety Option

2000 INTERNATIONAL 4900 16,000 GAWR FRONT AXLE WITH FRONT FRAME EXTENSION HR4000V1 FRONT HR4000A2 REAR	2000 INTERNATIONAL 4900 16,000 GAWR FRONT AXLE WITHOUT FRONT FRAME EXTENSION HR4000V1 FRONT HR4000A2 REAR
---	--

REQUIRED GROUPS

Front Guide Wheel Unit	179546	179546
Mounting Brackets	179543	179544
Steering Lock	186205	186205
Application Drawing - Front	022534	022569

ACCESSORY GROUP OPTIONS

* Rail Sweeps	179557	179557
Truck Brake Connection.	162114	162114
Hydraulic Power Pack - Full	137926	137926
Hydraulic Power Pack - Abbreviated	137927	137927
Sight Rod Kit And Extension	164574	164574
* Recommended Safety Option		

2001 INTERNATIONAL
2674
16,000 GAWR
FRONT AXLE
WITH FRONT
FRAME EXTENSION
HR4000V1 FRONT
HR4000A2 REAR

REQUIRED GROUPS

Front Guide Wheel Unit	179546
Mounting Brackets	179543
Steering Lock	186205
Application Drawing - Front	023189

ACCESSORY GROUP OPTIONS

- * Rail Sweeps 179557
 - Truck Brake Connection. 162114
 - Hydraulic Power Pack - Full 137926
 - Hydraulic Power Pack - Abbreviated 137927
 - Sight Rod Kit And Extension 164574
- * Recommended Safety Option

2001 INTERNATIONAL 4900 16,000 GAWR FRONT AXLE WITH FRONT FRAME EXTENSION HR4000V1 FRONT HR4000A2 REAR	2001 INTERNATIONAL 4900 16,000 GAWR FRONT AXLE WITHOUT FRONT FRAME EXTENSION HR4000V1 FRONT HR4000A2 REAR
---	--

REQUIRED GROUPS

Front Guide Wheel Unit	179546	179546
Mounting Brackets	179543	179544
Steering Lock	186205	186205
Application Drawing - Front	022534	022569

ACCESSORY GROUP OPTIONS

* Rail Sweeps	179557	179557
Truck Brake Connection.	162114	162114
Hydraulic Power Pack - Full.	137926	137926
Hydraulic Power Pack - Abbreviated	137927	137927
Sight Rod Kit And Extension	164574	164574
* Recommended Safety Option		

2002 INTERNATIONAL
2674
16,000 GAWR
FRONT AXLE
WITH FRONT
FRAME EXTENSION
HR4000V1 FRONT
HR4000A2 REAR

REQUIRED GROUPS

Front Guide Wheel Unit	179546
Mounting Brackets	179543
Steering Lock	186205
Application Drawing - Front	023189

ACCESSORY GROUP OPTIONS

- * Rail Sweeps 179557
 - Truck Brake Connection. 162114
 - Hydraulic Power Pack - Full 137926
 - Hydraulic Power Pack - Abbreviated 137927
 - Sight Rod Kit And Extension 164574
- * Recommended Safety Option

2002 INTERNATIONAL 4900 16,000 GAWR FRONT AXLE WITH FRONT FRAME EXTENSION HR4000V1 FRONT HR4000A2 REAR	2002 INTERNATIONAL 4900 16,000 GAWR FRONT AXLE WITHOUT FRONT FRAME EXTENSION HR4000V1 FRONT HR4000A2 REAR
---	--

REQUIRED GROUPS

Front Guide Wheel Unit	179546	179546
Mounting Brackets	179543	179544
Steering Lock	186205	186205
Application Drawing - Front	022534	022569

ACCESSORY GROUP OPTIONS

* Rail Sweeps	179557	179557
Truck Brake Connection.	162114	162114
Hydraulic Power Pack - Full	137926	137926
Hydraulic Power Pack - Abbreviated	137927	137927
Sight Rod Kit And Extension	164574	164574
* Recommended Safety Option		

1999 STERLING LT-7501 16,000 GAWR FRONT AXLE WITH FRONT FRAME EXTENSION HR4000V1 FRONT HR4000A2 REAR	1999 STERLING LT-7501 16,000 GAWR FRONT AXLE WITHOUT FRONT FRAME EXTENSION HR4000V1 FRONT HR4000A2 REAR
---	--

REQUIRED GROUPS

Front Guide Wheel Unit	179546	179546
Mounting Brackets	179139	179948
Steering Lock	179140	179140
Application Drawing - Front	022573	022614

ACCESSORY GROUP OPTIONS

* Rail Sweeps	179557	179557
Truck Brake Connection.	179161	179161
Hydraulic Power Pack - Full.	137926	137926
Hydraulic Power Pack - Abbreviated	137927	137927
Sight Rod Kit And Extension	164574	164574
* Recommended Safety Option		

2000 STERLING LT-7501 16,000 GAWR FRONT AXLE WITH FRONT FRAME EXTENSION HR4000V1 FRONT HR4000A2 REAR	2000 STERLING LT-7501 16,000 GAWR FRONT AXLE WITHOUT FRONT FRAME EXTENSION HR4000V1 FRONT HR4000A2 REAR
---	--

REQUIRED GROUPS

Front Guide Wheel Unit	179546	179546
Mounting Brackets	179139	179948
Steering Lock	179140	179140
Application Drawing - Front	022573	022614

ACCESSORY GROUP OPTIONS

* Rail Sweeps	179557	179557
Truck Brake Connection.	179161	179161
Hydraulic Power Pack - Full.	137926	137926
Hydraulic Power Pack - Abbreviated	137927	137927
Sight Rod Kit And Extension	164574	164574
* Recommended Safety Option		

2001 STERLING LT-7501 16,000 GAWR FRONT AXLE WITH FRONT FRAME EXTENSION HR4000V1 FRONT HR4000A2 REAR	2001 STERLING LT-7501 16,000 GAWR FRONT AXLE WITHOUT FRONT FRAME EXTENSION HR4000V1 FRONT HR4000A2 REAR
---	--

REQUIRED GROUPS

Front Guide Wheel Unit	179546	179546
Mounting Brackets	179139	179948
Steering Lock	179140	179140
Application Drawing - Front	022573	022614

ACCESSORY GROUP OPTIONS

* Rail Sweeps	179557	179557
Truck Brake Connection.	179161	179161
Hydraulic Power Pack - Full	137926	137926
Hydraulic Power Pack - Abbreviated	137927	137927
Sight Rod Kit And Extension	164574	164574
* Recommended Safety Option		

2002 STERLING LT-7501 16,000 GAWR FRONT AXLE WITH FRONT FRAME EXTENSION HR4000V1 FRONT HR4000A2 REAR	2002 STERLING LT-7501 16,000 GAWR FRONT AXLE WITHOUT FRONT FRAME EXTENSION HR4000V1 FRONT HR4000A2 REAR
---	--

REQUIRED GROUPS

Front Guide Wheel Unit	179546	179546
Mounting Brackets	179139	179948
Steering Lock	179140	179140
Application Drawing - Front	022573	022614

ACCESSORY GROUP OPTIONS

* Rail Sweeps	179557	179557
Truck Brake Connection.	179161	179161
Hydraulic Power Pack - Full.	137926	137926
Hydraulic Power Pack - Abbreviated	137927	137927
Sight Rod Kit And Extension	164574	164574
* Recommended Safety Option		

2001 VOLVO WHITE GMC WG64 16,000 GAWR FRONT AXLE WITH FRONT FRAME EXTENSION HR4000V1 FRONT HR4000A2 REAR	2002 VOLVO WHITE GMC WG64 16,000 GAWR FRONT AXLE WITH FRONT FRAME EXTENSION HR4000V1 FRONT HR4000A2 REAR
---	---

REQUIRED GROUPS

Front Guide Wheel Unit	179546	179546
Mounting Brackets	193979	193979
Steering Lock	194005	194005
Application Drawing - Front	023842	023842

ACCESSORY GROUP OPTIONS

* Rail Sweeps	179557	179557
Truck Brake Connection.	162130	162130
Hydraulic Power Pack - Full.	137926	137926
Hydraulic Power Pack - Abbreviated	137927	137927
Sight Rod Kit And Extension	164574	164574
* Recommended Safety Option		

Limited Warranty

HARSCO TRACK TECHNOLOGIES products are designed to give high quality service and are manufactured from high grade material, by competent workmen under careful supervision. Harsco Track Technologies, Harsco Corporation warrants products of its manufacture to be free of defects in material and workmanship, under normal use and service for a period of six (6) months from date of delivery to the original user. The obligation of Harsco Track Technologies, Harsco Corporation under this warranty is limited to repairing or replacing at its factories, or other location designated by it, any part or parts thereof which are returned within 30 days of the date when failure occurs or defect is noted, with transportation charges prepaid, and which upon examination appears to the satisfaction of Harsco Track Technologies, Harsco Corporation to have been defective. Such free repair or replacement does not include transportation charges, or the cost of installing the new part or any other expense incident thereto. Harsco Track Technologies, Harsco Corporation will not be liable for other loss, damage, or expense directly or indirectly arising from the use of its products, nor will Harsco Track Technologies, Harsco Corporation be liable for special, incidental or consequential damages.

Ordinary wear and tear, and damage from abuse, misuse, neglect or alteration are not covered by this warranty. Harsco Track Technologies, Harsco Corporation assumes no liability for expenses incurred or repairs made outside its factories except by written consent. This warranty is null and void if instructions and operating procedures are not followed.

Equipment or parts not manufactured by this company, but which are furnished in connection with HARSCO TRACK TECHNOLOGIES products, are covered directly by the warranty of the manufacturer supplying them. However, Harsco Track Technologies, Harsco Corporation will assist in obtaining adjustment on such equipment or parts when necessary.

THIS WARRANTY IS IN LIEU OF ALL OTHER WARRANTIES EXPRESSED OR IMPLIED INCLUDING ANY IMPLIED WARRANTIES OF MERCHANTABILITY OR FITNESS FOR A PARTICULAR PURPOSE AND OF ANY OTHER OBLIGATION OR LIABILITY OF HARSCO TRACK TECHNOLOGIES, HARSCO CORPORATION.

Product Improvement Liability Disclaimer

HARSCO TRACK TECHNOLOGIES, HARSCO CORPORATION RESERVES THE RIGHT TO MAKE ANY CHANGES IN OR IMPROVEMENTS ON ITS PRODUCTS WITHOUT INCURRING ANY LIABILITY OR OBLIGATION WHATEVER AND WITHOUT BEING REQUIRED TO MAKE ANY CORRESPONDING CHANGES OR IMPROVEMENTS IN PRODUCTS PREVIOUSLY MANUFACTURED OR SOLD.

Hazardous Material Disclaimer

THE PARTS/ASSEMBLIES THAT ARE USED IN THIS PRODUCT ARE CLASSIFIED AS "ARTICLES" ACCORDING TO 29 CFR 1910.1200 (C). THEY ARE FORMED TO A SPECIFIC SHAPE OR DESIGN DURING MANUFACTURE, HAVE END USE FUNCTION DEPENDENT UPON THEIR SHAPE OR DESIGN, AND DO NOT RELEASE ANY HAZARDOUS CHEMICAL UNDER NORMAL CONDITIONS OF USE. ACCORDINGLY, WE ARE NOT REQUIRED TO SUPPLY MATERIAL SAFETY DATA SHEETS (MSDS) OR TO LABEL SHIPPING CONTAINERS FOR "ARTICLES". HOWEVER, LUBRICANTS, LIQUIDS, GASEOUS CHEMICALS AND SOLIDS USED IN OPERATION OR MAINTENANCE OF THE PRODUCT MAY REQUIRE THAT USER'S TAKE OCCUPATIONAL PROTECTIVE MEASURES. MSDS SHEETS FOR SUCH MATERIALS WILL BE SUPPLIED TO YOUR PURCHASING MANAGER/SAFETY DIRECTOR TO BE USED IN YOUR EMPLOYEE SAFETY TRAINING EDUCATION AND ENVIRONMENTAL HEALTH TRAINING.

HTT

Harsco Track Technologies

Harsco

HARSCO TRACK TECHNOLOGIES
HARSCO CORPORATION
415 North Main Street
Fairmont, Minnesota, 56031-1837 U.S.A.

BULLETIN 1231A

Printed In U.S.A.

ISSUED 7 - 2002

© 2002 HARSCO TRACK TECHNOLOGIES, HARSCO CORPORATION