

HTT

Harsco Track Technologies

Harsco

SERIES 2654
UNIVERSAL HY-RAIL®
GUIDE WHEEL EQUIPMENT
HYDRAULICALLY OPERATED



90-178

OPERATOR'S SERVICE AND PARTS MANUAL

ISSUED 7 - 2002

BULLETIN 1143A

© 2002 HARSCO TRACK TECHNOLOGIES, HARSCO CORPORATION



■ **THIS MANUAL CONTAINS VITAL INFORMATION FOR THE SAFE USE AND EFFICIENT OPERATION OF THE VEHICLE EQUIPPED WITH HY-RAIL® GUIDE WHEEL EQUIPMENT. CAREFULLY READ THIS OPERATOR'S MANUAL BEFORE USING THE VEHICLE. FAILURE TO ADHERE TO THE INSTRUCTIONS COULD RESULT IN BODILY INJURY AND/OR PROPERTY DAMAGE.**

FAIRMONT™ is a brand name and trademark of products manufactured by Harsco Track Technologies, Harsco Corporation.

HY-RAIL® is a registered trademark of Harsco Track Technologies, Harsco Corporation.

When this manual is received, record the rail pilot unit serial numbers in the spaces provided in the General Information and Parts Sections for future reference, in case the serial number tags ever become unreadable. A Manual must remain with the vehicle. Additional or replacement manuals may be obtained by calling or writing Harsco Track Technologies, Harsco Corporation.

All information, illustrations and specifications in this manual are based on the latest information available at the time of publication. Harsco Track Technologies, Harsco Corporation reserves the right to make changes at any time without notice.

FACILITY LOCATIONS

Harsco Track Technologies

415 North Main Street
Fairmont, MN
56031-1837
Tel: (507) 235-3361
Fax: (507) 235-7370

Harsco Track Technologies

200 South Jackson Road
Ludington, MI
49431
Tel: (231) 843-3431
Fax: (231) 843-4830

Harsco Track Technologies

2401 Edmund Road, Box 20
Cayce-West Columbia, SC
29171-0020
Tel: (803) 822-9160
Fax: (803) 822-7471

Harsco Track Technologies

Giltway, Giltbrook
Nottingham, NG16 2GQ
England
Tel: 0115 938 7000
Fax: 0115 938 7001

Harsco Track Technologies

28 Eagle Road
Danbury, CT
06810
Tel: (203) 778-6811
Fax: (203) 778-8670

Harsco Track Technologies

4 Strathwyn Street, PO Box 5287
Brendale, Queensland 4500
Australia
Tel: 61 7 205 6500
Fax: 61 7 205 7369

TABLE OF CONTENTS

GENERAL INFORMATION

SECTION

1

OPERATION

SECTION

2

ADJUSTMENTS

SECTION

3

MAINTENANCE

SECTION

4

TROUBLESHOOTING

SECTION

5

APPENDICES

SECTION

6

PARTS

SECTION

7

VEHICLE APPLICATIONS

SECTION

8

SECTION

9

SECTION

10

SECTION 1 - GENERAL INFORMATION
TABLE OF CONTENTS

Safety Information

SAFETY INFORMATION 1 - 2

Identification View

IDENTIFICATION VIEW 1 - 5

Description

DESCRIPTION 1 - 6

Orientation

ORIENTATION 1 - 6

Serial Numbers

SERIAL NUMBERS 1 - 7

Specifications

VEHICLE 1 - 8
GUIDE WHEEL UNIT 1 - 8

1

Safety Information



SAFETY IS A CRITICAL FACTOR IN THE DESIGN OF HARSCO TRACK TECHNOLOGIES EQUIPMENT. THE BEST SAFETY PROGRAM STARTS WITH A SAFETY CONSCIOUS OPERATOR. THE SAFETY INFORMATION HIGHLIGHTED IN THIS BULLETIN DESCRIBES SAFE OPERATING PRACTICES FOR THE BENEFIT OF THE WORKERS WHO WILL USE OUR EQUIPMENT IN THEIR DAILY JOBS.

HAZARD SERIOUSNESS

Signal Words: **DANGER**, **WARNING** and **CAUTION** are used to identify levels of hazard seriousness.



DANGER - Immediate hazards which WILL result in sever bodily injury or death.



WARNING - Hazards or unsafe practices which COULD result in severe bodily injury or death.



CAUTION - Hazards or unsafe practices which COULD result in minor bodily injury and / or product or property damage.

Safety Information

1



- **APPLY THE VEHICLE PARKING BRAKE AND STOP THE ENGINE WHEN PERFORMING MAINTENANCE, MAKING ADJUSTMENTS, WORKING UNDER VEHICLE OR GUIDE WHEEL EQUIPMENT OR WHENEVER UNINTENDED MOVEMENT OF THE VEHICLE COULD OCCUR, UNLESS OTHERWISE INSTRUCTED IN THIS MANUAL.**
- **MAKE SURE ALL PERSONS ARE CLEAR OF VEHICLE BEFORE PERFORMING ANY OPERATING FUNCTIONS.**
- **KEEP ALL PARTS OF THE BODY AND LOOSE CLOTHING CLEAR OF ALL MOVING PARTS OF THE VEHICLE OR GUIDE WHEEL EQUIPMENT.**
- **UNDERSTAND EQUIPMENT OPERATION AND BE AWARE OF ALL PINCH POINTS BEFORE OPERATING OR MAKING ADJUSTMENTS TO GUIDE WHEEL EQUIPMENT.**
- **IF A DERAILMENT SHOULD OCCUR WHILE VEHICLE IS OPERATING IN ELECTRIFIED 3RD-RAIL TERRITORY, VEHICLE OR GUIDE WHEEL EQUIPMENT MIGHT BE IN ELECTRICAL CONTACT WITH ELECTRIFIED RAIL. DO NOT ATTEMPT TO EXIT FROM VEHICLE UNTIL ELECTRICAL POWER TO 3RD-RAIL HAS BEEN TURNED OFF.**
- **DO NOT EXCEED 25 MPH (40 km/h) WHEN OPERATING VEHICLE ON TRACK. RAILROAD RULES GOVERNING SPEEDS SHOULD BE OBSERVED AT ALL TIMES. REDUCE SPEED WHEN PROPELLING VEHICLE THROUGH SWITCHES, CROSSINGS, BRANCH LINES AND ANY SPECIAL TRACK WORKS. OPERATING VEHICLE AT UNSAFE SPEEDS COULD RESULT IN DERAILMENT OF VEHICLE.**
- **CHECK AND CORRECT GUIDE WHEEL EQUIPMENT ALIGNMENT PROMPTLY IF MISALIGNMENT IS INDICATED.**

Safety Information

1



- **AT MAXIMUM LOADED GROSS VEHICLE WEIGHT ON TRACK (including driver, passengers, equipment, tools, payload, etc.) DO NOT EXCEED ANY OF THE FOLLOWING:**
 - **VEHICLE'S G.V.W.R. (Gross Vehicle Weight Rating).**
 - **VEHICLE'S FRONT G.A.W.R. (Gross Axle Weight Rating) OR THE FRONT GUIDE WHEEL UNIT RATED LOAD CAPACITY, WHICHEVER IS LOWER.**
 - **VEHICLE'S REAR G.A.W.R. (Gross Axle Weight Rating) OR THE SUM OF THE REAR GUIDE WHEEL UNIT RATED LOAD CAPACITY PLUS (+) VEHICLE'S REAR TIRE/WHEEL RATED LOAD CAPACITY, WHICHEVER IS LOWER.**
 - **COMPONENTS RATED LOAD CAPACITY:**
 - A. **TIRE MANUFACTURER'S RATED LOAD CAPACITY**
 - B. **VEHICLE'S WHEEL RATED LOAD CAPACITY**
 - C. **GUIDE WHEEL EQUIPMENT RATED LOAD CAPACITY:**
 - FRONT GUIDE WHEEL UNIT: 14,000 lbs (6,350 kg) or 7,000 lbs (3,175 kg) maximum per side**
 - REAR GUIDE WHEEL UNIT: 13,400 lbs (6,078 kg) or 6,700 lbs (3,039 kg) maximum per side**

FAILURE TO HEED THESE WARNINGS COULD RESULT IN SEVERE BODILY INJURY.



- **OBSERVE AND FOLLOW ALL RAILROAD SAFETY RULES AND REGULATIONS.**
- **KNOW THE POSITIONS AND FUNCTIONS OF ALL CONTROLS BEFORE ATTEMPTING TO OPERATE VEHICLE.**
- **THIS GUIDE WHEEL EQUIPMENT IS DESIGNED WITH YOUR SAFETY IN MIND. NEVER DISCONNECT AND/OR ATTEMPT TO OVERRIDE SAFETY FEATURES.**

FAILURE TO HEED THESE PRECAUTIONS COULD RESULT IN BODILY INJURY AND/OR PROPERTY DAMAGE.

Note: To help ensure safe operation of this equipment, keep all safety decals clean and legible. Replace safety decals when necessary with new decals, listed in the Parts Section of this manual.

Identification View

1

FIGURE 1-1
SERIES 2654 HY-RAIL® GUIDE WHEEL EQUIPPED VEHICLE



Description

1

The Series 2654 HY-RAIL® guide wheel equipment can be applied to various cab chassis trucks with single or tandem rear axles and dual wheels. The vehicle's G.V.W.R. (gross vehicle weight rating) and/or G.A.W.R. (gross axle weight rating) must comply with the specified limits listed in the Harsco Track Technologies HY-RAIL® Vehicle Specifications Manual. Vehicles should be equipped with bias ply tires. Radial tires are not recommended. For information regarding special applications not listed in the Harsco Track Technologies HY-RAIL® Vehicle Specifications Manual, contact Harsco Track Technologies, Harsco Corporation, Fairmont, Minnesota.

The guide wheel units are raised and lowered hydraulically. Hydraulic power may be supplied from the vehicle system or from an optional power pack. The guide wheel units are mounted onto the vehicle frame. When the guide wheels are in the "highway" position, the weight of the guide wheel units is carried on the vehicle frame, above the springs. Bogie type guide wheel assemblies guide the vehicle during on track operation. The front guide wheel unit carries all of the vehicle front end load while the rear guide wheel unit uses a combination of the rear guide wheel unit suspension and vehicle suspension to carry the rear end load on track.

An axle locking mechanism holds the vehicle front axle and tires above the rail surface to ensure that the tires do not come into contact with the rails while the vehicle is propelling through crossings, switches, etc. A steering lock is used during on track operation. The steering lock holds the vehicle's steering wheel in place to ensure the vehicle's front tires remain straight.

The vehicle's rear inner dual wheels are used for propulsion on the track. On track braking is provided by the vehicle's rear brakes and optional guide wheel unit brakes, if so equipped. Since the guide wheel unit brakes are air over hydraulic, the vehicle on which the guide wheel equipment is mounted should be equipped with air brakes. If not, an electric / air system is available to provide air for the guide wheel unit brakes.

Vehicle Orientation

Front - rear and left - right are determined from the vehicle operator's seat.

Serial Numbers

When this bulletin is received, complete the following record from the serial number tag on the guide wheel units. Always provide these factory serial numbers when calling or writing about the units. The serial number tag is located on the frame assembly of the units.

FIGURE 1-2
FRONT GUIDE WHEEL UNIT SERIAL NUMBER TAG

HTT Harsco Track Technologies a harsco company™		PATENT NUMBER <input type="text"/>
WHEN ORDERING PARTS FOR THIS ACCESSORY ALWAYS GIVE THE FOLLOWING INFORMATION		
Fairmont ™ HY-RAIL® GUIDE WHEEL EQUIPMENT		
SERIAL NUMBER <input type="text"/>	SYMBOL <input type="text"/>	MODEL NUMBER <input type="text"/>
FAIRMONT, MN. 56031 U.S.A.		
52400K		

FIGURE 1-3
REAR GUIDE WHEEL UNIT SERIAL NUMBER TAG

HTT Harsco Track Technologies a harsco company™		PATENT NUMBER <input type="text"/>
WHEN ORDERING PARTS FOR THIS ACCESSORY ALWAYS GIVE THE FOLLOWING INFORMATION		
Fairmont ™ HY-RAIL® GUIDE WHEEL EQUIPMENT		
SERIAL NUMBER <input type="text"/>	SYMBOL <input type="text"/>	MODEL NUMBER <input type="text"/>
FAIRMONT, MN. 56031 U.S.A.		
52400K		

Specifications

1

VEHICLE

See the Harsco Track Technologies HY-RAIL® Vehicle Specifications Manual for vehicle specifications. For information regarding special applications not listed in the Harsco Track Technologies Vehicle Specifications Manual, contact Harsco Track Technologies, Harsco Corporation, Fairmont, Minnesota.

GUIDE WHEEL UNIT

Track Gauge 56-1/2 in (1435 mm)

Guide Wheels

Flange Diameter 14-3/4 in (375 mm)
Tread Diameter 12-1/2 in (318 mm)

Weight

Front Unit 1,600 lbs (726 kg)
Rear Unit 1,500 lbs (680 kg)

Maximum Guide Wheel Unit Load Capacity (with vehicle at curb weight)

Front Unit 14,000 lbs (6,350 kg)
Rear Unit * 13,400 lbs (6,078 kg)

Maximum Load Per Side (with vehicle at curb weight)

Front Unit 7,000 lbs (3,175 kg)
Rear Unit 6,700 lbs (3,039 kg)

* *The vehicle's rear inner dual wheels carry the remaining load capacity. Do not exceed the tire manufacturer's and/or wheel manufacturer's load rating capacity for the rear inner dual wheels when on track.*

**SECTION 2 - OPERATION
TABLE OF CONTENTS**

Speedometer

SPEEDOMETER 2 - 3

Preparing For Operation

VEHICLE 2 - 3
GUIDE WHEEL EQUIPMENT 2 - 4

Misalignment Indicators

MISALIGNMENT INDICATORS..... 2 - 4

Placing Vehicle On Track

PLACING VEHICLE ON TRACK 2 - 5
LOWER REAR GUIDE WHEELS..... 2 - 6
LOWER FRONT GUIDE WHEELS 2 - 8
STEERING LOCKS 2 - 9
RAIL BRAKES 2 - 9

Guide Wheel Load On Track

CHECKING FRONT GUIDE WHEEL LOAD ON TRACK 2 - 10
CHECKING REAR GUIDE WHEEL LOAD ON TRACK..... 2 - 12
CHECKING VEHICLE TIRE CLEARANCE ABOVE RAILS..... 2 - 13

Propelling On Track

PROPELLING ON TRACK..... 2 - 14

Braking On Track

BRAKING ON TRACK 2 - 15

Vehicles Equipped With Crane Or Aerial Lift Device

VEHICLES EQUIPPED WITH CRANE OR AERIAL LIFT DEVICE..... 2 - 16

Removing Vehicle From Track

REMOVING VEHICLE FROM TRACK.....	2 - 17
RAISING FRONT GUIDE WHEELS.....	2 - 18
RAISING REAR GUIDE WHEELS.....	2 - 20

2

Highway Operation

HIGHWAY OPERATION	2 - 21
-------------------------	--------

Towing

TOWING TRAILER / EQUIPMENT WITH VEHICLE ON TRACK	2 - 22
TOWING TRAILER / EQUIPMENT WITH VEHICLE ON ROAD	2 - 25
TOWING DISABLED VEHICLE ON TRACK	2 - 28
TOWING DISABLED VEHICLE ON ROAD	2 - 31

Speedometer



- **WHEN WHEEL/TIRE MODIFICATIONS ARE APPLIED, CHECK AND CHANGE SPEEDOMETER DRIVE RATIO IF NECESSARY. THE SPEEDOMETER DRIVE RATIO WILL INFLUENCE THE OPERATION OF THE VEHICLE'S ANTI-LOCK BRAKE SYSTEMS, ELECTRONICALLY CONTROLLED TRANSMISSION SHIFT TIMING AND SPEEDOMETER DISPLAY OF THE TRUE VEHICLE SPEED. FAILURE TO MAINTAIN CORRECT SPEEDOMETER DRIVE RATIO COULD RESULT IN SEVERE BODILY INJURY.**

2

Some vehicles require special larger diameter wheels and/or wheel spacers to properly space the vehicle tires for on track operation. Use of these wheel modifications may effect the speedometer drive ratio calibration. The speedometer drive ratio will influence the operation of the vehicle's anti-lock brake systems, electronically controlled transmission shift timing and speedometer display of the true vehicle speed. The vehicle speedometer must be re-calibrated when wheel modifications are applied to the vehicle. See the vehicle manufacturer or dealer for speedometer calibration information.

Preparing for Operation

VEHICLE

Be sure the vehicle is in operating condition by checking the following:

- a. Engine oil level.
- b. Radiator fluid level.
- c. Fuel tank level.
- d. Hydraulic reservoir oil level.
- e. Brakes work properly.
- f. Parking brake works properly.
- g. Head, brake and signal lights work properly.
- h. Tires properly inflated to the manufacturer's recommended maximum pressure printed on the sidewall of the tires, or the wheel manufacturer's recommended maximum pressure stamped on the wheel, whichever is lower.
- i. Vehicle wheels: Lug nuts / bolts tightened to the proper torque, inspect vehicle wheels, lug bolts and lug nuts for wear or damage. For vehicle wheel, lug bolt and lug nut inspection information refer to the USER'S GUIDE TO WHEELS AND RIMS produced by THE MAINTENANCE COUNCIL. To obtain this guide, contact:

THE MAINTENANCE COUNCIL
AMERICAN TRUCKING ASSOCIATION
2200 MILL ROAD
ALEXANDRIA, VA. 22314
Phone: (703) 838-1763

- j. Any other normal maintenance requirements.

Preparing for Operation

GUIDE WHEEL EQUIPMENT

Be sure the guide wheel equipment is in operating condition by checking the following:

2

- a. Air and hydraulic hoses and fittings for damage, wear or leaks.
- b. Overall for damaged or worn parts.
- c. Properly lubricated at the recommended operating mileage intervals.
- d. Brakes work properly.
- e. Hydraulic pressure properly adjusted.

Misalignment Indicators



■ **BEFORE OPERATING A VEHICLE WITH NEWLY INSTALLED GUIDE WHEEL EQUIPMENT ON TRACK, VERIFY THAT THE GUIDE WHEEL EQUIPMENT ALIGNMENT PROCEDURE HAS BEEN COMPLETED. CHECK AND CORRECT ALIGNMENT PROMPTLY IF MISALIGNMENT IS INDICATED. MISALIGNMENT OF GUIDE WHEEL EQUIPMENT COULD RESULT IN DERAILMENT OF VEHICLE AND SEVERE BODILY INJURY.**

The following conditions may indicate that minor adjustments to the guide wheel equipment alignment are necessary. If any of these conditions occur during operation, perform the Track Test, see Adjustment Section - Vehicle Track Test and/or complete the Alignment Procedure, see Adjustment - Guide Wheel Equipment Alignment Procedure.

1. Excessive flange or tread wear on any of the rail guide wheels.
2. Vehicle pulls noticeably to the left or the right during on track operation.
3. Vibration felt throughout the vehicle at various speeds during on track operation.

Placing Vehicle On Track



- PLACE VEHICLE AUTOMATIC TRANSMISSION IN "PARK" OR MANUAL TRANSMISSION IN "NEUTRAL". APPLY THE PARKING BRAKE.
- UNDERSTAND EQUIPMENT OPERATION AND BE AWARE OF ALL PINCH POINTS BEFORE OPERATING OR MAKING ADJUSTMENTS TO GUIDE WHEEL EQUIPMENT.
- BEFORE PROPELLING VEHICLE ON THE TRACK, MAKE SURE:
 - FRONT AND REAR GUIDE WHEELS ARE LOWERED AND LOCKED IN RAIL POSITION, AND SECURED WITH LOCK PIN.
 - ALL RAIL GUIDE WHEEL FLANGES ARE ENGAGED ON INSIDE RAIL.
 - AXLE HOOKS ARE ENGAGED UNDER THE VEHICLE FRONT AXLE, HOLDING THE VEHICLE FRONT TIRES A MINIMUM OF 1-1/2" (38 mm) ABOVE THE RAIL.
 - STEERING WHEEL LOCK IS ENGAGED.
 - BRAKE CONTROL VALVE IS IN THE "ON" POSITION AND GUIDE WHEEL BRAKE EQUIPMENT IS FUNCTIONAL.

FAILURE TO HEED THESE WARNINGS COULD RESULT IN DERAILMENT OF VEHICLE AND SEVERE BODILY INJURY.



- WHEN USING VEHICLE MECHANICAL PTO HYDRAULIC PUMP TO LOWER GUIDE WHEEL EQUIPMENT, DO NOT EXCEED HYDRAULIC SYSTEM FLOW OF 8 GPM. EXCESSIVE FLOW COULD DAMAGE HYDRAULIC SYSTEM COMPONENTS
- OBSERVE AND FOLLOW ALL RAILROAD SAFETY RULES AND REGULATIONS.
- IF THE VEHICLE IS EQUIPPED WITH A STROBE LIGHT (BEACON) AND RAILROAD RULES AND REGULATIONS REQUIRE ITS USE, THE STROBE LIGHT (BEACON) MUST BE ILLUMINATED WHEN PLACING THE VEHICLE ON TRACK AND WHEN OPERATING THE VEHICLE ON TRACK.

FAILURE TO HEED THESE PRECAUTIONS COULD RESULT IN BODILY INJURY AND/OR PROPERTY DAMAGE.

Placing Vehicle On Track

LOWERING GUIDE WHEELS

1. Ensure that highway vehicles are not approaching the grade crossing while placing the vehicle on track. Flag the crossing per railroad rules and regulations to ensure safety.
2. At a road crossing, drive the vehicle about 25 feet (7.6 m) past the track. Back the vehicle onto the rails so that the rear vehicle wheels are centered on the rails. On vehicles with dual rear wheels, the inner dual wheels must be centered on the rails. It may be necessary to move the vehicle back and forth several times to get the wheels centered on the rail properly.
3. Place the vehicle automatic transmission in "PARK" or manual transmission in "NEUTRAL". Apply the parking brake.
4. Engage the mechanical PTO hydraulic pump or start the auxiliary hydraulic power source. If the vehicle is equipped with an auxiliary control valve, place the valve in the proper position to direct hydraulic oil flow to the guide wheel equipment.
5. Lower and lock the rear guide wheels first. The rear guide wheels should be lowered first so the front tires of the vehicle can be maneuvered to align the front guide wheels with the rails.

Placing Vehicle On Track

LOWERING REAR GUIDE WHEELS - See Figure 2-1

1. Remove lock pin (1). Button in "T" end of pin must be pressed in to remove the pin.
2. Pull control valve handle (2) up to slightly raise the guide wheels. This will release any pressure on the lock mechanism..
3. Rotate and hold lock handle (3) clockwise to disengage the lock. While holding lock handle (3) in the released position, push control valve handle (2) down to lower the guide wheels.
4. When the guide wheels are fully lowered, release the control valve handle. Make sure the flanges on all four guide wheels are engaged on the inside of the rails.
5. Rotate lock handle (3) back to the engaged position. Install lock pin (1). Button in "T" end of lock pin must be pushed in to install pin.

FIGURE 2-1
LOWERING REAR GUIDE WHEELS

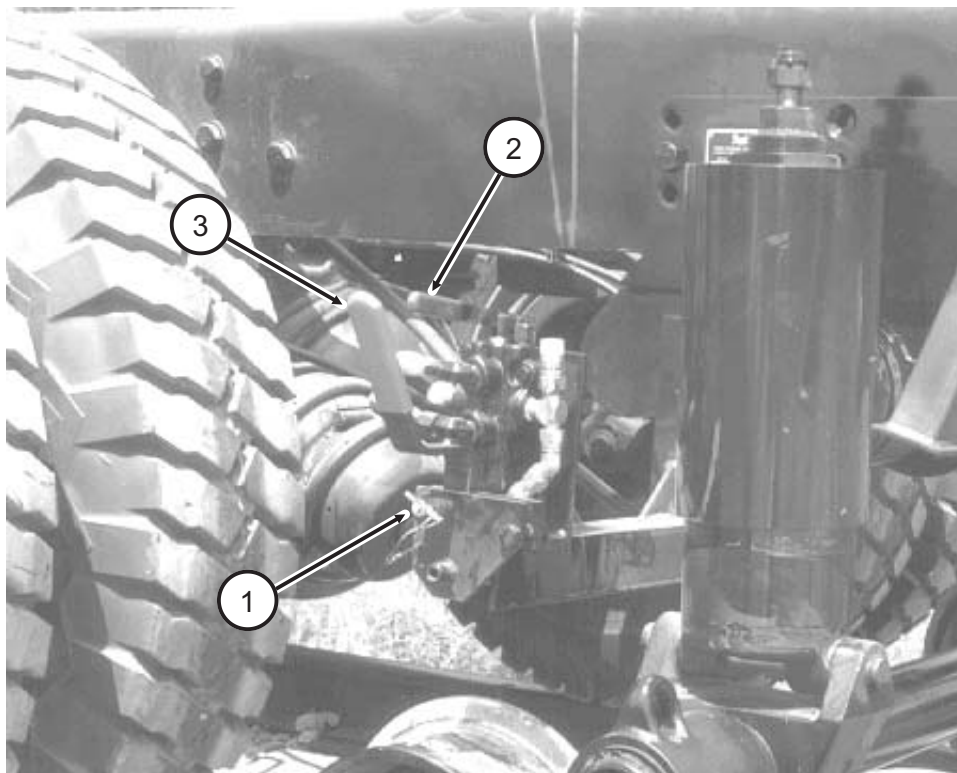

Placing Vehicle On Track

LOWERING FRONT GUIDE WHEELS - See Figure 2-2

2

1. Engage the axle hooks under the front axle. Pull control rod (1) out and lift up so that the collar on the rod can be moved through the large hole in plate (2). Push control rod (1) towards the vehicle until the axle hooks are engaged under the axle. Ensure that both axle hooks are engaged under the vehicle's axle.

Note: On some vehicle applications the axle hooks may be reversed and will engage under the axle from the rear instead of from the front. This will cause the axle hook control rod to engage and disengage the axle hooks in the opposite direction.

2. Remove lock pin (3). Push control valve handle (4) in to slightly raise the guide wheels. This will release any pressure on the mechanical lock mechanism.
3. Push and hold lock handle (5) towards the vehicle. While holding lock handle (5) in the released position, pull control valve handle (4) out to lower the guide wheels.
4. When the guide wheels are fully lowered, release the control valve handle. Make sure the flanges on all four guide wheels are engaged on the inside of the rails.
5. Pull lock handle (5) forward to the locked position. Install lock pin (3).

FIGURE 2-2
LOWERING FRONT GUIDE WHEELS

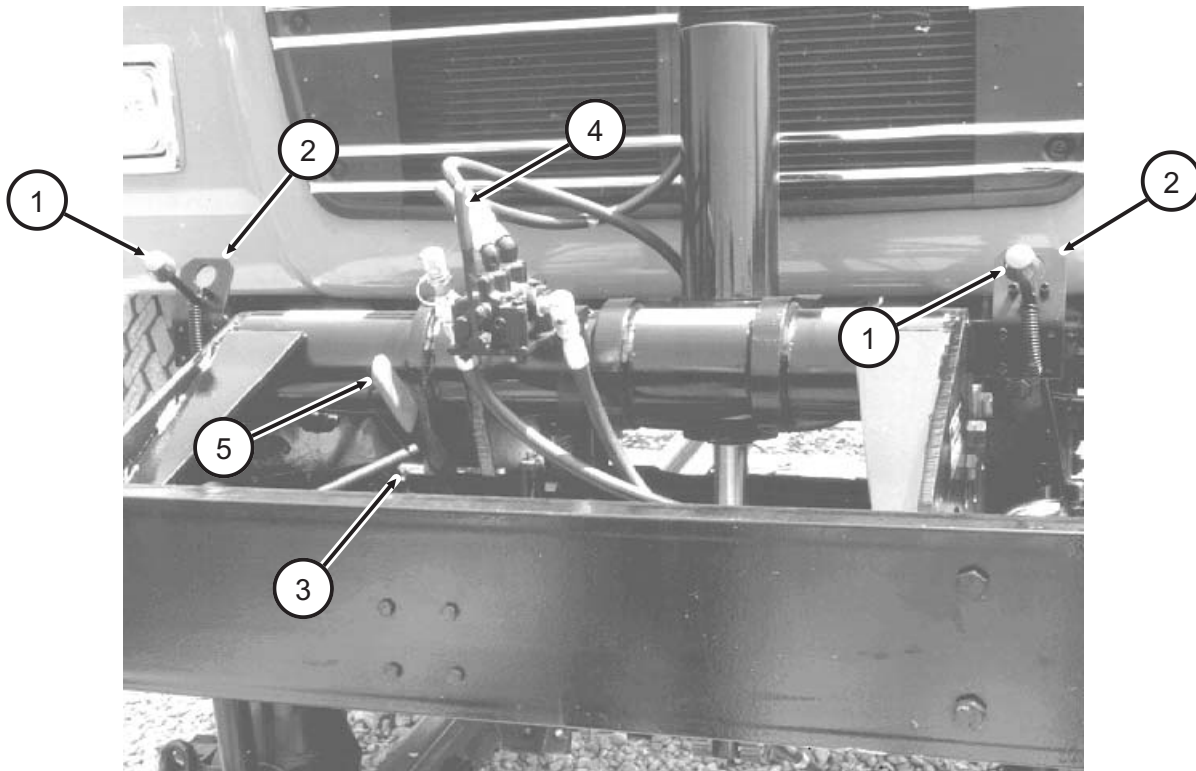

Placing Vehicle On Track

LOWERING GUIDE WHEELS

Stop the auxiliary hydraulic power source or disengage the mechanical PTO hydraulic pump. If the vehicle is equipped with an auxiliary control valve, place the valve in the proper position to shut off hydraulic oil flow to the guide wheel equipment.

STEERING LOCKS - See Figures 2-3 and 2-4

Set the vehicle front wheels straight ahead and secure the steering wheel in that position by engaging the steering lock on the steering column. Steering locks may vary from vehicle to vehicle but will operate similarly.

Note: Do not place your hands or any pressure on the steering wheel after the steering lock is engaged.

FIGURE 2-3
STEERING LOCK DISENGAGED

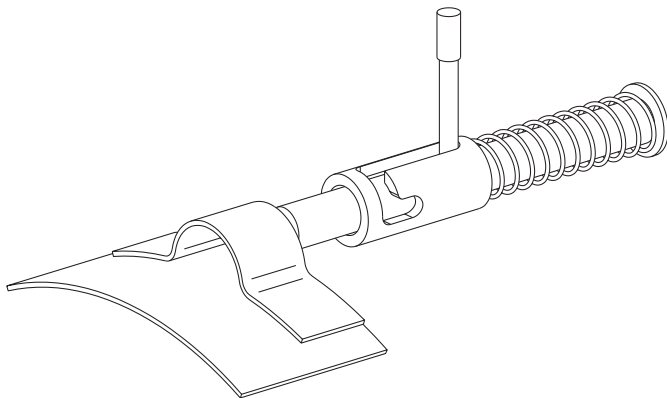

SE99A191A-1

FIGURE 2-4
STEERING LOCK ENGAGED

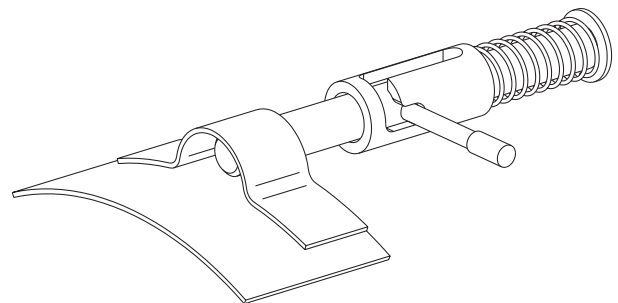

SE99A192A-1

RAIL BRAKES

Move the Rail Wheel Brake control valve to the ON position to activate the guide wheel equipment brakes whenever the vehicle is on track. The vehicle brake pedal will actuate the vehicle brakes and the guide wheel equipment brakes simultaneously.

Guide Wheel Load On Track



2

- **IMPROPER LOADING OF GUIDE WHEEL EQUIPMENT CAN CAUSE DERAILMENT OF VEHICLE.**
 - **ALWAYS CHECK THE GUIDE WHEEL LOAD BEFORE OPERATING THE VEHICLE ON TRACK. NEVER OPERATE THE VEHICLE ON TRACK IF LOAD EXCEEDS THE MAXIMUM RATED LOAD OF THE FRONT AND/OR REAR GUIDE WHEEL UNITS.**
 - **THE MAXIMUM LOAD ON THE FRONT GUIDE WHEEL UNIT IS 14,000 LBS (6,350 kg) OR 7,000 LBS (3,175 kg) MAXIMUM PER SIDE.**
 - **THE MAXIMUM LOAD ON THE REAR GUIDE WHEEL UNIT IS 13,400 LBS (6,078 kg) OR 6,700 LBS (3,039 kg) MAXIMUM PER SIDE.**
 - **REAR GUIDE WHEEL UNIT MUST BE ADJUSTED TO CARRY APPROXIMATELY 50% OF VEHICLE REAR AXLE CURB WEIGHT OR A MINIMUM OF 5,300 LBS (2,404 kg).**
 - **NEVER OPERATE THE VEHICLE ON TRACK IF CLEARANCE BETWEEN VEHICLE FRONT TIRES AND RAIL IS LESS THAN 1-1/2" (38 mm).**
 - **APPLY PARKING BRAKE AND STOP VEHICLE ENGINE BEFORE CHECKING GUIDE WHEEL LOAD AND VEHICLE FRONT TIRE TO RAIL CLEARANCE.**
- FAILURE TO HEED THESE WARNINGS COULD RESULT IN DERAILMENT OF VEHICLE AND/OR SEVERE BODILY INJURY.**

Whenever the vehicle is loaded or additional load is added to the existing vehicle load on track, check the load on both the front and rear guide wheel units. The maximum load on the front guide wheel unit is 14,000 lbs (6,350 kg) or 7,000 lbs (3,175 kg) maximum per side. The maximum load on the rear guide wheel unit is 13,400 lbs (6,078 kg) or 6,700 lbs (3,039 kg) maximum per side.

CHECKING FRONT GUIDE WHEEL LOAD - See Chart 2-5 and Figure 2-6

1. Apply the parking brake. Stop the vehicle's engine.
2. The protrusion of rod (1) on the spring cell is used to determine the load on the front guide wheels. Measure dimension (L) on both spring cells. See Chart 2-5 to convert dimension (L) to the load on the guide wheel.
3. The maximum load on the front guide wheel unit is 14,000 lbs (6,350 kg) or 7,000 lbs (3,175 kg) maximum per side. The front guide wheel unit spring cells are non-adjustable. If the load exceeds the maximum rated load capacity of the front guide wheel unit or the maximum rated load capacity of either side of the guide wheel unit, the load must be redistributed or some of the load removed. Never operate the vehicle on track if the load on the front guide wheel unit exceeds the maximum rated load capacity.

Guide Wheel Load On Track

CHECKING FRONT GUIDE WHEEL LOAD - Continued

CHART 2-5
 FRONT GUIDE WHEEL LOAD

DIMENSION (L)		APPROXIMATE LOAD PER SIDE	
1/4"	(6.4 mm)	1940 lbs	(880 kg)
1/2"	(12.7 mm)	3405 lbs	(1544 kg)
3/4"	(19.0 mm)	4865 lbs	(2206 kg)
1"	(25.4 mm)	6330 lbs	(2871 kg)
* 1-1/4"	(31.8 mm)	7795 lbs	(3535 kg)

* **FRONT GUIDE WHEELS ARE OVERLOADED. REDISTRIBUTE OR REMOVE SOME OF THE LOAD. THE MAXIMUM LOAD ON THE FRONT GUIDE WHEEL UNIT IS 14,000 LBS (6,350 kg) OR 7,000 LBS (3,175 kg) MAXIMUM PER SIDE.**

FIGURE 2-6
 FRONT SPRING CELL

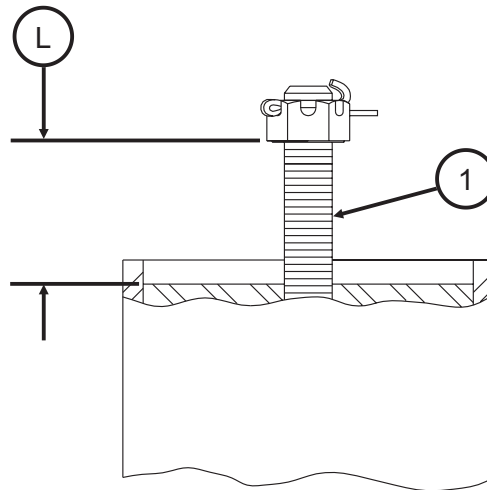

SE90A149A-1

Guide Wheel Load On Track

CHECKING REAR GUIDE WHEEL LOAD - See Chart 2-7 and Figure 2-8

2

1. Apply the parking brake. Stop the vehicle's engine.
2. The protrusion of rod (1) on the spring cell is used to determine the load on the rear guide wheels. Measure dimension (L) on both spring cells. See Chart 2-7 to convert dimension (L) to the load on the guide wheel.
3. The maximum rated load on the rear guide wheel unit is 13,400 lbs (6,078 kg) or 6,700 lbs (3,039 kg) maximum per side. The rear guide wheel unit must also be adjusted to carry approximately 50% of vehicle rear axle curb weight or a minimum of 5,300 lbs (2,404 kg).
4. The rear guide wheel unit spring cells are adjustable. See the Adjustment Section - Guide Wheel Load for the adjustment procedure. If the load exceeds the maximum rated load capacity of the rear guide wheel unit or the maximum rated load capacity of either side of the guide wheel unit, the load must be redistributed or some of the load removed. Never operate the vehicle on track if the load on the rear guide wheel unit exceeds the maximum rated load capacity.

CHART 2-7
REAR GUIDE WHEEL LOAD

DIMENSION (L)		APPROXIMATE LOAD PER SIDE	
1/4"	(6.4 mm)	1200 lbs	(544 kg)
1/2"	(12.7 mm)	1950 lbs	(885 kg)
3/4"	(19.0 mm)	2675 lbs	(1213 kg)
1"	(25.4 mm)	3410 lbs	(1547 kg)
1-1/4"	(31.8 mm)	4140 lbs	(1878 kg)
1-1/2"	(38.1 mm)	4880 lbs	(2214 kg)
1-3/4"	(44.5 mm)	5610 lbs	(2545 kg)
2"	(50.8 mm)	6345 lbs	(2878 kg)
* 2-1/4"	(57.2 mm)	7080 lbs	(3211 kg)

* **REAR GUIDE WHEELS ARE OVERLOADED. REDISTRIBUTE OR REMOVE SOME OF THE LOAD. THE MAXIMUM LOAD ON THE REAR GUIDE WHEEL UNIT IS 13,400 LBS (6,078 kg) OR 6,700 LBS (3,039 kg) MAXIMUM PER SIDE.**

Guide Wheel Load On Track

CHECKING REAR GUIDE WHEEL LOAD - Continued

FIGURE 2-8
REAR SPRING CELL

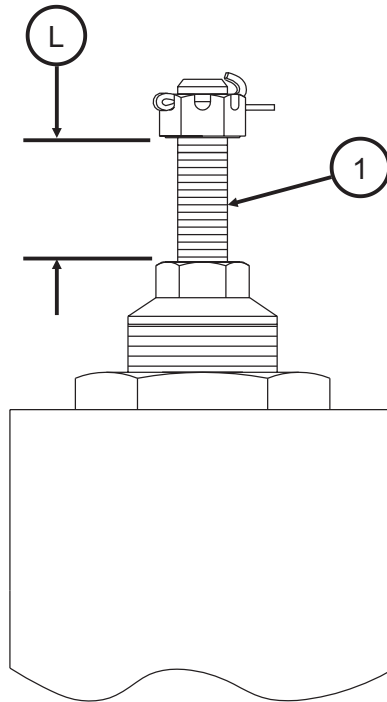

SE90A150A-1

CHECKING VEHICLE FRONT TIRE CLEARANCE ABOVE RAIL

If the vehicle's front tire clearance above the rail is less than 1-1/2" (38 mm) see the Adjustment Section - Vehicle Front Wheel Clearance. Never operate the vehicle on track when the front tire clearance above the rail is less than 1-1/2" (38 mm).

Propelling On Track

2



- **IMPROPER LOADING OF HY-RAIL® EQUIPPED VEHICLE CAN CAUSE DERAILMENT OF VEHICLE.**
- **ALWAYS CHECK GUIDE WHEEL LOAD BEFORE OPERATING THE VEHICLE ON TRACK.**
- **NEVER OPERATE VEHICLE ON TRACK IF LOAD EXCEEDS MAXIMUM RATED LOAD OF FRONT AND/OR REAR GUIDE WHEEL UNITS.**
- **NEVER OPERATE VEHICLE ON TRACK IF CLEARANCE BETWEEN VEHICLE FRONT TIRE AND RAIL IS LESS THAN 1-1/2" (38 mm).**

FAILURE TO HEED THESE WARNINGS COULD RESULT IN DERAILMENT OF VEHICLE AND/OR SEVERE BODILY INJURY.



- **BEFORE OR WHEN PROPELLING ON TRACK:**
 - **OBSERVE AND FOLLOW ALL RAILROAD SAFETY RULES AND REGULATIONS.**
 - **OPERATOR MUST LOOK IN ALL DIRECTIONS FOR PERSONS OR OBJECTS ON OR ADJACENT TO THE TRACK.**
 - **DO NOT ACCELERATE SUDDENLY. TRACTION IS REDUCED ON TRACK, SPINNING VEHICLE TIRES COULD DAMAGE THEM.**
 - **DO NOT EXCEED 25 MPH (40 km/h) WHEN OPERATING VEHICLE ON TRACK. RAILROAD RULES GOVERNING SPEEDS SHOULD BE OBSERVED AT ALL TIMES. REDUCE SPEED WHEN PROPELLING VEHICLE THROUGH SWITCHES, ROAD CROSSINGS, BRANCH LINES AND ANY SPECIAL TRACK WORKS. OPERATING VEHICLE AT UNSAFE SPEEDS COULD RESULT IN DERAILMENT OF THE VEHICLE.**
 - **STEERING LOCK MUST BE ENGAGED AT ALL TIMES WHEN OPERATING VEHICLE ON TRACK.**
 - **IF THE VEHICLE IS EQUIPPED WITH A STROBE LIGHT (BEACON) AND RAILROAD RULES AND REGULATIONS REQUIRE ITS USE, THE STROBE LIGHT (BEACON) MUST BE ILLUMINATED WHEN OPERATING THE VEHICLE ON TRACK.**

FAILURE TO HEED THESE PRECAUTIONS COULD RESULT IN BODILY INJURY AND/OR PROPERTY DAMAGE.

Vehicles equipped with the Series 2654 HY-RAIL® Guide Wheel Equipment use the vehicle propulsion system to propel on track. Do not accelerate suddenly. Traction is reduced on track. Spinning the vehicle tires could damage them.

Braking On Track



- PERSONS WHO OPERATE THE VEHICLE MUST BE FAMILIAR WITH TRACK AND WEATHER CONDITIONS THAT MAY AFFECT STOPPING DISTANCE. BE ALERT TO THESE CONDITIONS AND ALLOW ADEQUATE STOPPING DISTANCE.
- BE PREPARED TO BRAKE AT ALL HIGHWAY CROSSINGS. THIS VEHICLE MAY NOT OPERATE TRACK SIGNAL CIRCUITS, AND ONCOMING VEHICLES OR PEDESTRIANS MAY NOT YIELD THE RIGHT OF WAY.
- RAIL WHEEL BRAKE CONTROL VALVE MUST BE IN THE "ON" POSITION WHENEVER VEHICLE IS ON TRACK.

FAILURE TO HEED THESE PRECAUTIONS COULD RESULT IN BODILY INJURY AND/OR PROPERTY DAMAGE.

The Series 2654 HY-RAIL® Guide Wheel Equipment may be equipped with brakes. If the guide wheel units are equipped with brakes, the vehicle uses a combination of the guide wheel unit brakes and the vehicle's rear axle brake system for braking on track. The guide wheel unit brakes will apply simultaneously when the vehicle brakes are applied. Stopping distance is greater on track than on typical road surfaces. Apply the brakes gradually to avoid sliding the vehicle tires and rail guide wheels.

Vehicles Equipped With Crane Or Aerial Lift Device



2

- WHEN OPERATING CRANE, AERIAL LIFT DEVICE, ETC., WHILE THE VEHICLE'S GUIDE WHEELS ARE ON THE RAILS, DO NOT OVERLOAD THE GUIDE WHEEL EQUIPMENT OR EXCEED THE CAPACITY OF ANY OF THE EQUIPMENT BEING USED.
- THE UNIT SHOULD BE EQUIPPED WITH OUTRIGGERS TO HELP PREVENT ACCIDENTS AND THE POSSIBILITY OF DAMAGE TO THE GUIDE WHEEL EQUIPMENT. WHEN USING THE EQUIPMENT TO TRANSFER ANY LOAD, SET THE OUTRIGGERS ON A STABLE BASE TO PREVENT SETTLING OF THE OUTRIGGERS AND SHIFTING OF THE VEHICLE.
- IF OPERATING CONDITIONS REQUIRE LIFTING A LOAD WITH THE CRANE WHILE ON RAIL, BUT WITHOUT THE OUTRIGGERS BEING USED, THE LOAD APPLIED BY LIFTING WITH THE CRANE MUST NOT OVERLOAD ANY COMPONENT OF THE GUIDE WHEEL EQUIPMENT.
- CAREFULLY READ THE CRANE OR AERIAL LIFT DEVICE OPERATOR'S MANUAL FOR THE SAFE USE AND EFFICIENT OPERATION OF THE EQUIPMENT.

FAILURE TO HEED THESE WARNINGS COULD CAUSE DERAILMENT OF THE VEHICLE RESULTING IN SEVERE BODILY INJURY AND/OR DEATH.

Removing Vehicle From Track



- PLACE VEHICLE AUTOMATIC TRANSMISSION IN "PARK" OR MANUAL TRANSMISSION IN "NEUTRAL". APPLY THE PARKING BRAKE.

- UNDERSTAND EQUIPMENT OPERATION AND BE AWARE OF ALL PINCH POINTS BEFORE OPERATING OR MAKING ADJUSTMENTS TO GUIDE WHEEL EQUIPMENT.

- BEFORE PROPELLING VEHICLE OFF TRACK, MAKE SURE:

- FRONT AND REAR GUIDE WHEELS ARE RAISED, LOCKED IN THE HIGHWAY POSITION, AND LOCKS SECURED WITH THE LOCK PINS.
- AXLE HOOKS ARE FULLY DISENGAGED FROM UNDER VEHICLE FRONT AXLE.
- STEERING WHEEL LOCK IS DISENGAGED.

FAILURE TO HEED THESE WARNINGS COULD RESULT IN SEVERE BODILY INJURY.



- WHEN USING VEHICLE MECHANICAL PTO HYDRAULIC PUMP TO RAISE GUIDE WHEEL EQUIPMENT, DO NOT EXCEED HYDRAULIC SYSTEM FLOW OF 8 GPM. EXCESSIVE FLOW COULD DAMAGE HYDRAULIC SYSTEM COMPONENTS

- OBSERVE AND FOLLOW ALL RAILROAD SAFETY RULES AND REGULATIONS.

- IF THE VEHICLE IS EQUIPPED WITH A STROBE LIGHT (BEACON) AND RAILROAD RULES AND REGULATIONS REQUIRE ITS USE, THE STROBE LIGHT (BEACON) MUST BE ILLUMINATED WHEN OPERATING AND REMOVING THE VEHICLE FROM TRACK.

FAILURE TO HEED THESE PRECAUTIONS COULD RESULT IN BODILY INJURY AND/OR PROPERTY DAMAGE.

Removing Vehicle From Track

1. Ensure that highway vehicles are not approaching the grade crossing while placing the vehicle on track. Flag the crossing per railroad rules and regulations to ensure safety.
2. Approach the crossing and stop with the vehicle front wheels on the crossing.
3. Place the vehicle automatic transmission in "PARK" or manual transmission in "NEUTRAL". Apply the parking brake.
4. Move the Rail Wheel Brake control valve to the OFF position, whenever the vehicle is removed from the track for highway use.
5. Engage the mechanical PTO hydraulic pump or start the auxiliary hydraulic power source. If the vehicle is equipped with an auxiliary control valve, place the valve in the proper position to direct hydraulic oil flow to the guide wheel equipment.

RAISING FRONT GUIDE WHEELS - See Figure 2-9

1. Remove lock pin (3). Pull control valve handle (4) out to slightly lower the guide wheels. This will release any pressure on the mechanical lock mechanism.
2. Push and hold lock handle (5) towards the vehicle. While holding lock handle (5) in the released position, push control valve handle (4) in to raise the guide wheels.
3. When the guide wheels are fully raised, release the control valve handle.
4. Pull lock handle (5) forward to the locked position. Install lock pin (3).
5. Disengage the axle hooks from under the front axle. Lift control rod (1) so that the collar on the rod can be moved through the large hole in plate (2). Pull control rod (1) out and lower it so the collar engages under the roll pins on plate (2). Repeat the procedure to disengage the axle hook on the opposite side of the vehicle. Ensure that both axle hooks are fully disengaged from under the vehicle's axle and that there is at least 3/4 inch (19 mm) of clearance between the axle hooks and the front axle.

Note: On some vehicle applications the axle hooks may be reversed and will engage under the axle from the rear instead of from the front. This will cause the axle hook control rod to engage and disengage the axle hooks in the opposite direction.

Removing Vehicle From Track

RAISING FRONT GUIDE WHEELS

FIGURE 2-9
RAISING FRONT GUIDE WHEELS

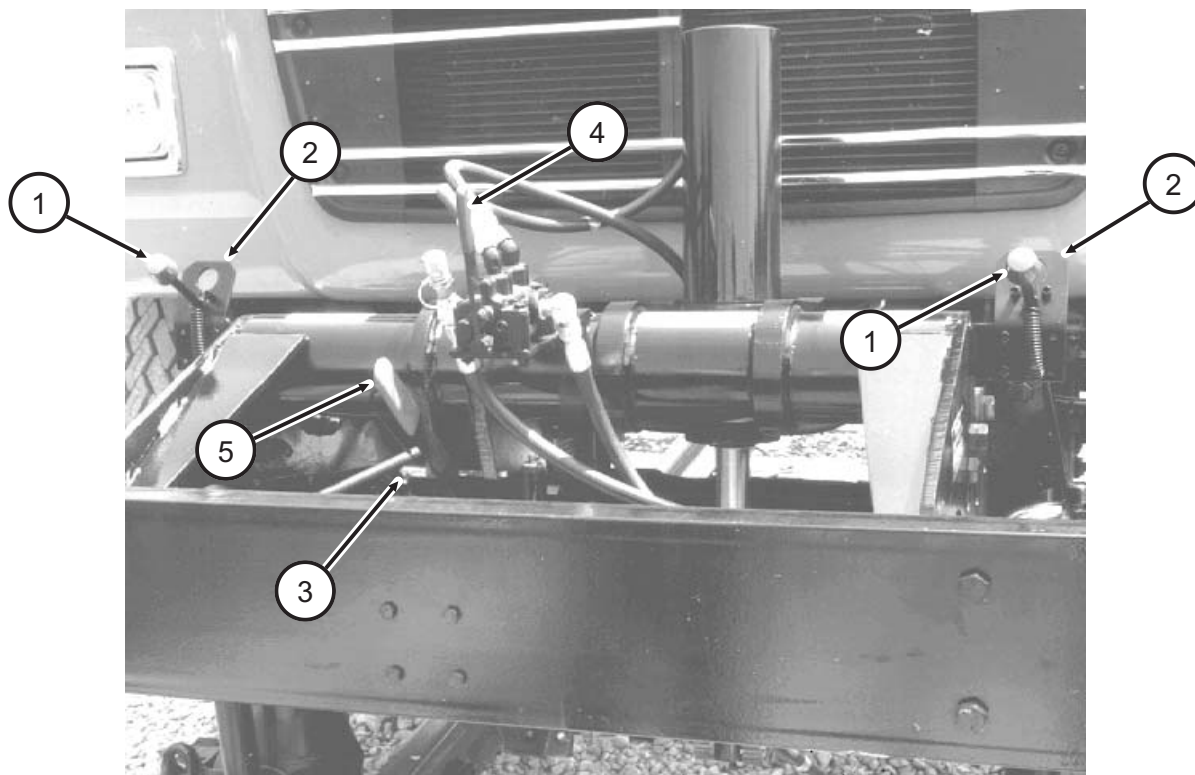

Removing Vehicle From Track

RAISING REAR GUIDE WHEELS - See Figure 2-10

1. Remove lock pin (1). Button in "T" end of pin must be pressed in to remove the pin.
2. Push control valve handle (2) down to slightly lower the guide wheels. This will release any pressure on the lock mechanism..
3. Rotate and hold lock handle (3) clockwise to disengage the lock. While holding lock handle (3) in the released position, pull control valve handle (2) up to raise the guide wheels.
4. When the guide wheels are fully raised, release the control valve handle.
5. Rotate lock handle (3) back to the engaged position. Install lock pin (1). Button in "T" end of lock pin must be pushed in to install pin.

FIGURE 2-10
RAISING REAR GUIDE WHEELS

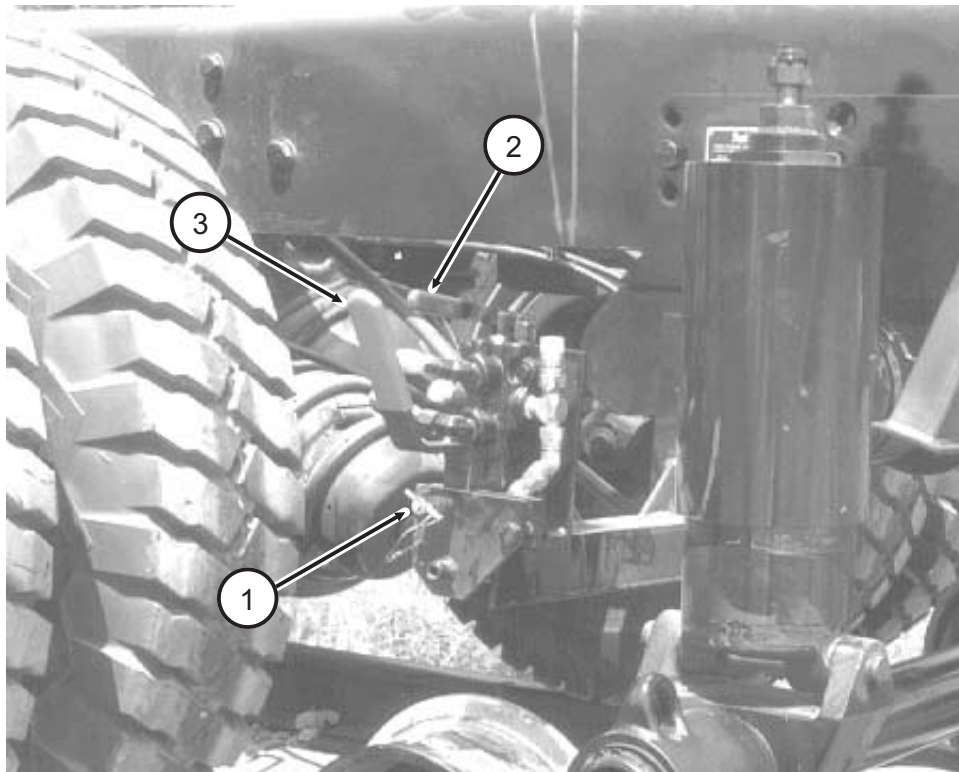

Removing Vehicle From Track

6. Disengage the mechanical PTO hydraulic pump or stop the auxiliary hydraulic power source. If the vehicle is equipped with an auxiliary control valve, place the valve in the proper position to shut off hydraulic oil flow to the guide wheel equipment.
7. See Figures 2-11 and 2-12. Disengage the vehicle steering lock located on the steering column. Steering locks may vary from vehicle to vehicle but will operate similarly.

2

FIGURE 2-11
STEERING LOCK DISENGAGED

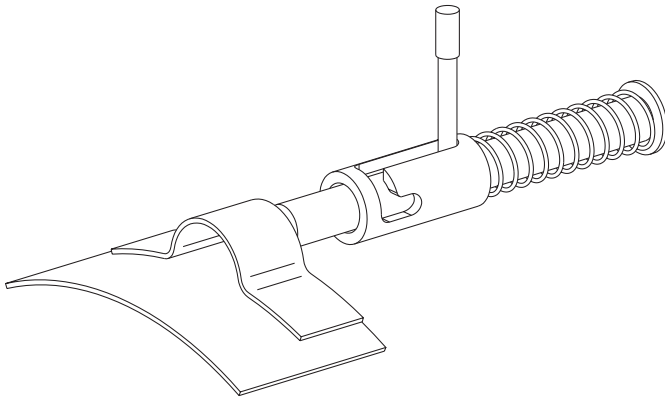

SE99A191A-1

FIGURE 2-12
STEERING LOCK ENGAGED

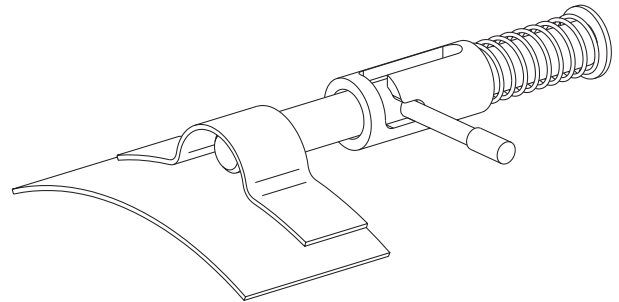

SE99A192A-1

Highway Operation



- **THIS MULTIPURPOSE VEHICLE HAS SPECIAL DESIGN AND EQUIPMENT FEATURES FOR OFF-ROAD USE. IT HANDLES DIFFERENTLY FROM AN ORDINARY PASSENGER CAR IN DRIVING CONDITIONS WHICH MAY OCCUR ON STREETS, HIGHWAYS AND OFF-ROAD. WEIGHT AND LOCATION OF AVAILABLE PAYLOAD MAY ALSO AFFECT THE HANDLING OF THIS VEHICLE. DRIVE WITH CARE AND WEAR SAFETY BELTS AT ALL TIMES. READ VEHICLE OWNER'S MANUAL FOR ADDITIONAL PRECAUTIONS.**

Towing Trailer / Equipment With Vehicle On Track



2

- VEHICLE USED FOR TOWING MUST BE RATED BY VEHICLE MANUFACTURER FOR WEIGHT OF TRAILER / EQUIPMENT TO BE TOWED. DO NOT EXCEED VEHICLE MANUFACTURER'S MAXIMUM RATED TOWING CAPACITY.
- TOWING VEHICLE MUST WEIGH AS MUCH OR MORE THAN TRAILER / EQUIPMENT BEING TOWED.
- VEHICLE USED FOR TOWING MUST HAVE AN ADEQUATE BRAKE SYSTEM TO SAFELY DECELERATE AND STOP TOWING VEHICLE AND TRAILER / EQUIPMENT BEING TOWED.
- TOWING TRAILER / EQUIPMENT LENGTHENS STOPPING DISTANCES. ALLOW ADEQUATE DISTANCE FOR STOPPING. ANTICIPATE STOPS SO YOU CAN BRAKE GRADUALLY.
- STOPPING DISTANCE IS GREATER ON TRACK THAN ON TYPICAL ROAD SURFACES. APPLY BRAKES GRADUALLY TO AVOID SLIDING VEHICLE TIRES AND GUIDE WHEELS.
- TOW TRAILER / EQUIPMENT AT A REASONABLE SPEED (20 MPH MAXIMUM) TAKING INTO ACCOUNT TRACK CONDITIONS, TRACK GRADE, WEATHER, VISIBILITY AND STOPPING DISTANCE TO ASSURE SAFE OPERATION. RAILROAD RULES GOVERNING SPEEDS AND RIGHT OF WAY SHOULD BE OBSERVED AT ALL TIMES.
- TRAILER / EQUIPMENT BEING TOWED MUST BE IN A SAFE, USABLE CONDITION TO BE TOWED.
- MAKE SURE THAT VEHICLE'S:
 - FRONT AND REAR GUIDE WHEEL ARE LOWERED AND LOCKED IN THE RAIL POSITION.
 - ALL GUIDE WHEEL FLANGES ARE ENGAGED ON INSIDE OF RAILS.
 - AXLE HOOKS MUST BE FULLY ENGAGED UNDER VEHICLE FRONT AXLE HOLDING VEHICLE FRONT TIRES A MINIMUM OF 1-1/2" (38 mm) ABOVE RAIL.
 - VEHICLE STEERING WHEEL LOCK ENGAGED WITH FRONT WHEELS STRAIGHT AHEAD.

FAILURE TO HEED THESE WARNINGS COULD RESULT IN SEVERE BODILY INJURY.

Towing Trailer / Equipment With Vehicle On Track



- CAREFULLY AND THOROUGHLY PREPARE VEHICLE FOR TOWING, MAKING SURE TO USE THE RIGHT TOWING EQUIPMENT AND TO ATTACH IT PROPERLY.
- TOWING EQUIPMENT (HITCHES, TOW BARS, ETC.) MUST BE ATTACHED TO VEHICLE FRAME. DO NOT MOUNT OR ATTACH TOWING EQUIPMENT TO VEHICLE'S GUIDE WHEEL EQUIPMENT.
- TOWING EQUIPMENT (HITCHES, TOW BARS, ETC.) MUST HAVE A RATED TOWING CAPACITY EQUAL TO OR GREATER THAN WEIGHT OF TRAILER / EQUIPMENT BEING TOWED.
- USE A RIGID TYPE TOW BAR WITH SAFETY LOCKING COUPLERS. DO NOT USE CHAIN, WIRE ROPE ETC.
- OBSERVE AND FOLLOW ALL RAILROAD SAFETY RULES AND REGULATIONS.
- DO NOT ACCELERATE SUDDENLY. TRACTION IS REDUCED ON RAIL, SPINNING VEHICLE TIRES COULD DAMAGE THEM.
- ALWAYS CHOCK TRAILER WHEELS BEFORE UNHOOKING TRAILER FROM TOWING VEHICLE.

FAILURE TO HEED THESE PRECAUTIONS COULD RESULT IN BODILY INJURY AND/OR PROPERTY DAMAGE.

Towing Trailer / Equipment With Vehicle On Track

2

1. See your vehicle's operators manual for towing information.
2. Use the vehicle manufacturer's recommendations to determine the maximum weight the towing vehicle can tow. Do not exceed vehicle manufacturer's maximum rated towing capacity.
3. The towing vehicle must have an adequate brake system to safely decelerate and stop the towing vehicle and the trailer / equipment being towed. The towing vehicle must weigh as much or more than the trailer / equipment being towed.
4. Make sure that the vehicle's:
 - a. Front and rear guide wheels are lowered and locked in the rail position.
 - b. All guide wheel flanges are engaged on the inside of the rails.
 - c. Axle hooks must be fully engaged under the vehicle front axle holding the vehicle front tires a minimum of 1-1/2" (38 mm) above the rail.
 - d. Vehicle front wheels are set straight ahead and the steering wheel lock is engaged on the steering column.
5. Make sure the towing vehicle and the trailer / equipment are in good working condition (tires, brakes, lights, etc.) and that current maintenance has been performed on the vehicle and trailer / equipment.
6. The towing equipment (hitches, tow bars, etc.) on the towing vehicle must have a rating equal to or greater than the weight of the trailer / equipment being towed.
7. The towing equipment (hitches, tow bars, etc.) must be attached to the towing vehicle frame. Do not mount or attach the towing equipment to the vehicle's guide wheel equipment.
8. Observe and follow all railroad safety rules and regulations.
9. Do not accelerate suddenly. Traction is reduced on rail. Spinning the vehicle tires could damage them.
10. Stopping distance is greater on rail than on typical road surfaces. Apply the vehicle brakes gradually to avoid sliding the vehicle tires and the guide wheels. Towing trailer / equipment lengthens stopping distances. Allow adequate distance for stopping. Anticipate stops so that you can brake gradually.
11. Tow the trailer / equipment on the track at a reasonable speed (20 MPH maximum) taking into account track conditions, track grade, weather, visibility and stopping distance to assure safe operation. Railroad rules and regulations governing speed limits and right of way should be observed at all times.
12. Always chock the trailer wheels before unhooking the trailer from the towing vehicle.

Towing Trailer / Equipment With Vehicle On Road



- VEHICLE USED FOR TOWING MUST BE RATED BY VEHICLE MANUFACTURER FOR WEIGHT OF TRAILER / EQUIPMENT TO BE TOWED. DO NOT EXCEED VEHICLE MANUFACTURER'S MAXIMUM RATED TOWING CAPACITY.
- VEHICLE USED FOR TOWING MUST HAVE AN ADEQUATE BRAKE SYSTEM TO SAFELY DECELERATE AND STOP TOWING VEHICLE AND TRAILER / EQUIPMENT BEING TOWED.
- TOWING TRAILER / EQUIPMENT LENGTHENS STOPPING DISTANCES. ALLOW ADEQUATE DISTANCE FOR STOPPING. ANTICIPATE STOPS SO YOU CAN BRAKE GRADUALLY.
- TOW TRAILER / EQUIPMENT AT A REASONABLE SPEED TAKING INTO ACCOUNT ROAD CONDITIONS, ROAD GRADE, WEATHER, VISIBILITY AND STOPPING DISTANCE TO ASSURE SAFE OPERATION. POSTED SPEED LIMITS SHOULD BE OBSERVED AT ALL TIMES.
- TRAILER / EQUIPMENT BEING TOWED MUST BE IN A SAFE, USABLE CONDITION TO BE TOWED.
- MAKE SURE THAT VEHICLE'S:
 - FRONT AND REAR GUIDE WHEELS ARE RAISED AND LOCKED IN HIGHWAY POSITION.
 - AXLE HOOKS MUST BE FULLY DISENGAGED FROM UNDER VEHICLE FRONT AXLE.
 - VEHICLE STEERING WHEEL LOCK DISENGAGED.

FAILURE TO HEED THESE WARNINGS COULD RESULT IN SEVERE BODILY INJURY.

Towing Trailer / Equipment With Vehicle On Road



2

- THIS MULTIPURPOSE VEHICLE HAS SPECIAL DESIGN AND EQUIPMENT FEATURES FOR OFF-ROAD USE. IT HANDLES DIFFERENTLY FROM AN ORDINARY PASSENGER CAR IN DRIVING CONDITIONS WHICH MAY OCCUR ON STREETS, HIGHWAYS AND OFF-ROAD. WEIGHT AND LOCATION OF AVAILABLE PAYLOAD MAY ALSO AFFECT THE HANDLING OF THIS VEHICLE. DRIVE WITH CARE AND WEAR SAFETY BELTS AT ALL TIMES. READ VEHICLE OWNER'S MANUAL FOR ADDITIONAL PRECAUTIONS.

- OBSERVE AND FOLLOW ALL FEDERAL, STATE AND LOCAL DRIVING RULES AND REGULATIONS.

- STATE LAWS MAY REQUIRE TOWING VEHICLE AND TRAILER / EQUIPMENT BEING TOWED TO BE EQUIPPED WITH SPECIAL SAFETY EQUIPMENT (MIRRORS ON BOTH SIDES OF TOWING VEHICLE, TRAILER BRAKES, TRAILER LIGHTS, ETC.).

- CAREFULLY AND THOROUGHLY PREPARE YOUR VEHICLE FOR TOWING, MAKING SURE TO USE THE RIGHT TOWING EQUIPMENT AND TO ATTACH IT PROPERLY.

- TOWING EQUIPMENT (HITCHES, TOW BARS, ETC.) MUST BE ATTACHED TO VEHICLE FRAME. DO NOT MOUNT OR ATTACH TOWING EQUIPMENT TO VEHICLE'S GUIDE WHEEL EQUIPMENT.

- TOWING EQUIPMENT (HITCH, TOW BAR, ETC.) MUST HAVE A RATED TOWING CAPACITY EQUAL TO OR GREATER THAN WEIGHT OF TRAILER / EQUIPMENT BEING TOWED.

- ALWAYS CHOCK TRAILER WHEELS BEFORE UNHOOKING TRAILER FROM TOWING VEHICLE.

FAILURE TO HEED THESE PRECAUTIONS COULD RESULT IN BODILY INJURY AND/OR PROPERTY DAMAGE.

Towing Trailer / Equipment With Vehicle On Road

1. See your vehicle's operators manual for towing information.
2. Use the vehicle manufacturer's recommendations to determine the maximum weight the towing vehicle can tow. Do not exceed vehicle manufacturer's maximum rated towing capacity.
3. The towing vehicle must have an adequate brake system to safely decelerate and stop the towing vehicle and the trailer / equipment being towed. Towing trailer / equipment lengthens stopping distances. Allow adequate distance for stopping. Anticipate stops so that you can brake gradually.
4. Make sure that the vehicle's:
 - a. Front and rear guide wheels are raised and locked in the highway position.
 - b. Axle hooks must be fully disengaged from under the vehicle front axle.
 - c. Vehicle steering wheel lock is disengaged on the steering column.
5. Make sure the towing vehicle and the trailer / equipment are in good working condition (tires, brakes, lights, etc.) and that current maintenance has been performed on the vehicle and trailer / equipment.
6. The towing equipment (hitches, tow bars, etc.) on the towing vehicle must have a rating equal to or greater than the weight of the trailer / equipment being towed.
7. The towing equipment (hitches, tow bars, etc.) must be attached to the towing vehicle frame. Do not mount or attach the towing equipment to the vehicle's guide wheel equipment.
8. Observe and follow all federal, state and local driving rules, regulations and laws.
9. State laws may require the towing vehicle and/or the trailer / equipment being towed to be equipped with special safety equipment (mirrors on both sides of the towing vehicle, trailer brakes, trailer lights, etc.).
10. Tow the trailer / equipment on the road at a reasonable speed taking into account road conditions, road grade, weather, visibility and stopping distance to assure safe operation. Always observe posted speed limits.
11. Always chock the trailer wheels before unhooking the trailer from the towing vehicle.

Towing Disabled Vehicle On Track



2

- TOWING VEHICLE / MACHINE MUST WEIGH AS MUCH OR MORE THAN DISABLED VEHICLE BEING TOWED.
- VEHICLE / MACHINE USED FOR TOWING MUST HAVE AN ADEQUATE BRAKE SYSTEM TO SAFELY DECELERATE AND STOP TOWING VEHICLE / MACHINE AND DISABLED VEHICLE BEING TOWED.
- TOWING DISABLED VEHICLE LENGTHENS STOPPING DISTANCES. ALLOW ADEQUATE DISTANCE FOR STOPPING. ANTICIPATE STOPS SO YOU CAN BRAKE GRADUALLY.
- TOW DISABLED VEHICLE AT A REASONABLE SPEED (10 MPH MAXIMUM) TAKING INTO ACCOUNT TRACK CONDITIONS, TRACK GRADE, WEATHER, VISIBILITY AND STOPPING DISTANCE TO ASSURE SAFE OPERATION. RAILROAD RULES GOVERNING SPEED LIMITS AND RIGHT OF WAY SHOULD BE OBSERVED AT ALL TIMES.
- STOPPING DISTANCE IS GREATER ON TRACK THAN ON TYPICAL ROAD SURFACES. APPLY BRAKES GRADUALLY TO AVOID SLIDING TOWING VEHICLE / MACHINE WHEELS.
- MAKE SURE THAT DISABLED VEHICLE'S:
 - FRONT AND REAR GUIDE WHEELS ARE LOWERED AND LOCKED IN RAIL POSITION.
 - ALL GUIDE WHEEL FLANGES ARE ENGAGED ON INSIDE OF RAILS.
 - AXLE HOOKS MUST BE FULLY ENGAGED UNDER VEHICLE FRONT AXLE HOLDING VEHICLE FRONT TIRES A MINIMUM OF 1-1/2" (38 mm) ABOVE RAIL.
 - VEHICLE STEERING WHEEL LOCK ENGAGED WITH FRONT WHEELS STRAIGHT AHEAD.

FAILURE TO HEED THESE WARNINGS COULD RESULT IN SEVERE BODILY INJURY.

Towing Disabled Vehicle On Track



- TOW BAR MUST BE ATTACHED TO DISABLED VEHICLE'S FRAME. DO NOT MOUNT OR ATTACH TOW BAR TO DISABLED VEHICLE'S GUIDE WHEEL EQUIPMENT.
- TOW BAR MUST HAVE A RATED TOWING CAPACITY EQUAL TO OR GREATER THAN WEIGHT OF DISABLED VEHICLE BEING TOWED.
- USE A RIGID TYPE TOW BAR WITH SAFETY LOCKING COUPLERS. DO NOT USE CHAIN, WIRE ROPE ETC.
- OBSERVE AND FOLLOW ALL RAILROAD SAFETY RULES AND REGULATIONS.
- DO NOT ACCELERATE SUDDENLY. TRACTION IS REDUCED ON RAIL, SPINNING TOWING VEHICLE / MACHINE WHEELS COULD DAMAGE THEM.
- TOW DISABLED VEHICLE TO NEAREST ROAD CROSSING AND REMOVE FROM TRACK.

FAILURE TO HEED THESE PRECAUTIONS COULD RESULT IN BODILY INJURY AND/OR PROPERTY DAMAGE.

Towing Disabled Vehicle On Track

2

1. See your vehicle's operators manual for towing information.
2. The towing vehicle / machine must have an adequate brake system to safely decelerate and stop the towing vehicle / machine and the disabled vehicle being towed. The towing vehicle / machine must weigh as much or more than the disabled vehicle towed.
3. Make sure that the disabled vehicle's:
 - a. Front and rear guide wheels are lowered and locked in the rail position.
 - b. All guide wheel flanges are engaged on the inside of the rails.
 - c. Axle hooks must be fully engaged under the vehicle front axle holding the vehicle front tires a minimum of 1-1/2" (38 mm) above the rail.
 - d. Vehicle front wheels are set straight ahead and the steering wheel lock is engaged on the steering column.
4. Make sure the towing vehicle / machine is in good working condition (tires, brakes, lights, etc.) and that current maintenance has been performed on the vehicle / machine.
5. The towing equipment (hitches, tow bars, etc.) on the towing vehicle / machine must have a rating equal to or greater than the weight of the disabled vehicle being towed.
6. The tow bar must be mounted or attached to the disabled vehicle's frame. Do not mount or attach the tow bar to the disabled vehicle's guide wheel equipment. Use a rigid type tow bar with safety locking couplers.
7. Observe and follow all railroad safety rules and regulations.
8. Do not accelerate suddenly. Traction is reduced on rail. Spinning the towing vehicle tires / machine wheels could damage them.
9. Stopping distance is greater on rail than on typical road surfaces. Apply the towing vehicle / machine brakes gradually to avoid sliding the vehicle tires / machine wheels. Towing disabled vehicle lengthens stopping distances. Allow adequate distance for stopping. Anticipate stops so that you can brake gradually.
10. Tow the disabled vehicle on the track at a reasonable speed (10 MPH maximum) taking into account track conditions, track grade, weather, visibility and stopping distance to assure safe operation. Railroad rules and regulations governing speed limits and right of way should be observed at all times.
11. Tow the disabled vehicle to the nearest road crossing and remove the vehicle from the track.

Towing Disabled Vehicle On Road



- TOW DISABLED VEHICLE PER VEHICLE MANUFACTURER'S TOWING SPECIFICATIONS LISTED IN YOUR VEHICLE'S OPERATORS MANUAL.
- VEHICLE USED FOR TOWING MUST HAVE AN ADEQUATE BRAKE SYSTEM TO SAFELY DECELERATE AND STOP TOWING VEHICLE AND DISABLED VEHICLE BEING TOWED.
- TOW DISABLED VEHICLE AT A REASONABLE SPEED TAKING INTO ACCOUNT ROAD CONDITIONS, ROAD GRADE, WEATHER, VISIBILITY AND STOPPING DISTANCE TO ASSURE SAFE OPERATION. POSTED SPEED LIMITS SHOULD BE OBSERVED AT ALL TIMES.
- MAKE SURE DISABLED VEHICLE'S:
 - FRONT AND REAR GUIDE WHEELS ARE RAISED AND LOCKED IN HIGHWAY POSITION.
 - AXLE HOOKS MUST BE FULLY DISENGAGED FROM UNDER VEHICLE FRONT AXLE.
 - VEHICLE STEERING WHEEL LOCK DISENGAGED.

FAILURE TO HEED THESE WARNINGS COULD RESULT IN SEVERE BODILY INJURY.



- TOWING EQUIPMENT (TOW TRUCK, TOW BARS, ETC.) MUST BE ATTACHED TO DISABLED VEHICLE'S FRAME. DO NOT MOUNT OR ATTACH TOWING EQUIPMENT TO DISABLED VEHICLE'S GUIDE WHEEL EQUIPMENT.
- TOWING EQUIPMENT (TOW TRUCK, TOW BARS, ETC.) MUST HAVE A RATED TOWING CAPACITY EQUAL TO OR GREATER THAN WEIGHT OF DISABLED VEHICLE BEING TOWED.
- OBSERVE AND FOLLOW ALL FEDERAL, STATE AND LOCAL DRIVING RULES AND REGULATIONS.
- STATE LAWS MAY REQUIRE TOWING VEHICLE AND DISABLED VEHICLE TO BE EQUIPPED WITH SPECIAL SAFETY EQUIPMENT (LIGHTS, ETC.).

FAILURE TO HEED THESE PRECAUTIONS COULD RESULT IN BODILY INJURY AND/OR PROPERTY DAMAGE.

Towing Disabled Vehicle On Road

1. See your vehicle's operators manual for towing information.
2. The towing vehicle must have an adequate brake system to safely decelerate and stop the towing vehicle and the disabled vehicle being towed.
3. Make sure that the disabled vehicle's:
 - a. Front and rear guide wheels are raised and locked in the highway position.
 - b. Axle hooks must be fully disengaged from under the vehicle front axle.
 - c. Vehicle steering wheel lock is disengaged on the steering column.
4. Make sure the towing vehicle is in good working condition (tires, brakes, lights, etc.) and that current maintenance has been performed on the vehicle.
5. The towing equipment (tow truck, tow bars, etc.) on the towing vehicle must have a rating equal to or greater than the weight of the disabled vehicle being towed.
6. The towing equipment (tow truck, tow bars, etc.) must be mounted or attached to the disabled vehicle's frame. Do not mount or attach the towing equipment to the disabled vehicle's guide wheel equipment.
7. Observe and follow all federal, state and local driving rules, regulations and laws.
8. State laws may require the towing vehicle and disabled vehicle being towed to be equipped with special safety equipment (lights, etc.).
9. Tow the disabled vehicle on the road at a reasonable speed taking into account road conditions, road grade, weather, visibility and stopping distance to assure safe operation. Always observe posted speed limits.

**SECTION 3 - ADJUSTMENTS
TABLE OF CONTENTS**

Guide Wheel Equipment Alignment Procedure

VEHICLE CHECK 3 - 2
PLACING VEHICLE ON TRACK 3 - 3
GUIDE WHEEL TRACK GAUGE 3 - 4
 Checking Guide Wheel Track Gauge A Toe-In / Toe-Out 3 - 4
 Adjusting Track Gauge 3 - 4
 Adjusting Toe-In / Toe-Out 3 - 4
GUIDE WHEEL LOAD ON TRACK 3 - 6
 Front Guide Wheel Load On Track 3 - 6
 Rear Guide Wheel Load On Track 3 - 8
 Adjusting Rear Guide Wheel Load 3 - 9
STRING LINING SET-UP 3 - 11
GUIDE WHEEL ALIGNMENT 3 - 12
VEHICLE TRACK TEST 3 - 14



Adjustments

VEHICLE FRONT TIRE CLEARANCE - RAIL POSITION 3 - 16
AXLE HOOK CLEARANCE - HIGHWAY POSITION 3 - 18
FRONT GUIDE WHEEL UNIT LOCK ADJUSTMENT 3 - 20
REAR GUIDE WHEEL UNIT LOCK ADJUSTMENT 3 - 22
RAIL SWEEP CLEARANCE 3 - 24
BRAKE SHOE CLEARANCE 3 - 25
FRONT GUIDE WHEEL UNIT HYDRAULIC PRESSURE 3 - 26
 Checking Control Valve Relief Pressure 3 - 26
 Adjusting Control Valve Relief Pressure 3 - 26
REAR GUIDE WHEEL UNIT HYDRAULIC PRESSURE 3 - 28
 Checking Control Valve Relief Pressure 3 - 28
 Adjusting Control Valve Relief Pressure 3 - 28
FLOW DIVIDER VALVE HYDRAULIC PRESSURE 3 - 30
 Checking Flow Divider Valve Relief Pressure 3 - 30
 Adjusting Flow Divider Valve Relief Pressure 3 - 30

Guide Wheel Equipment Alignment Procedure



3

- **APPLY THE VEHICLE PARKING BRAKE AND STOP THE ENGINE WHEN PERFORMING MAINTENANCE, MAKING ADJUSTMENTS, WORKING UNDER VEHICLE OR GUIDE WHEEL EQUIPMENT OR WHENEVER UNINTENDED MOVEMENT OF THE VEHICLE COULD OCCUR.**
- **ENGINE MUST BE RUNNING TO OPERATE MECHANICAL PTO HYDRAULIC PUMP TO RAISE / LOWER THE GUIDE WHEELS. BEFORE PERFORMING ANY ADJUSTMENTS TO GUIDE WHEEL EQUIPMENT OR VEHICLE, ALWAYS PLACE AUTOMATIC TRANSMISSION IN "PARK" OR MANUAL TRANSMISSION IN "NEUTRAL". APPLY THE PARKING BRAKE**
- **UNDERSTAND EQUIPMENT OPERATION AND BE AWARE OF ALL PINCH POINTS BEFORE OPERATING OR MAKING ADJUSTMENTS TO THE GUIDE WHEEL EQUIPMENT.**

FAILURE TO HEED THESE WARNINGS COULD RESULT IN SEVERE BODILY INJURY.

The Guide Wheel Alignment Procedure must be completed when the guide wheel equipment is applied to the vehicle, or when any of the misalignment indicators occur. See Operation - Misalignment Indicators.

VEHICLE CHECK

1. The vehicle must be at curb weight with permanent attachments: spare tire, tool box less tools, utility box, crane, aerial lift boom, etc. and without: passengers, baggage, load, etc.
2. Weigh the entire vehicle and record this weight. Weigh both the front and rear axles of the vehicle separately and record these weights. These weights will be used when calculating the guide wheel load.
3. Permanent attachments to the vehicle such as a tool box, utility box, crane, aerial lift boom, etc. which could cause uneven loading on the guide wheels should be compensated for, by adjusting the vehicle suspension by adding leaf springs, coil springs, torsion bars, etc.
4. Tires must be inflated to the tire manufacturer's recommended maximum pressure printed on the sidewalls of the tires or wheel manufacturer's recommended maximum pressure, stamped on the wheel, whichever is lower.
5. Visually inspect the entire vehicle, especially the guide wheel equipment, for loose or missing bolts, and bent or damaged components. Tighten, repair, or replace as necessary.

Guide Wheel Equipment Alignment Procedure

VEHICLE CHECK

6. Verify that the vehicle the guide wheel equipment is to be mounted to is equipped correctly (springs, tires, wheels, etc.). See the Harsco Track Technologies HY-RAIL® Vehicle Specifications Manual.
7. Check the following measurements on the vehicle that the guide wheel equipment is to be mounted on before applying the guide wheel equipment to the vehicle.
 - a. Frame must be square. Diagonal measurements of the frame should be equal within 1/8 inch (3.2 mm).
 - b. Wheelbase (as measured on each side) must be equal within 1/16 inch (1.8 mm).
 - c. Vehicle axles must be square with the frame within 1/64 inch per foot (.4 mm per 304 mm). Harsco Track Technologies, Harsco Corporation recommends that this be checked by a reputable alignment shop.
8. Follow the mounting instructions on the application drawings which are supplied with each Guide Wheel Equipment Group.
9. After mounting the guide wheel equipment to the vehicle, have the caster, camber, and toe-in checked on the vehicle front wheels. If necessary, adjust to vehicle manufacturer's recommendations.
10. Have the headlight aim checked and adjusted, if necessary.

PLACING VEHICLE ON TRACK

1. Place the vehicle on straight, level, tangent track or an alignment rack constructed for guide wheel equipment alignment. If track or an alignment rack is not available, use 4 x 4 inch lumber on a level floor to simulate track. Space the lumber so it measures 56-1/2 inches (1.435 m) between the inside edges.
2. Place the vehicle automatic transmission in "Park" or manual transmission in "Neutral". Apply the parking brake. Lower and lock the guide wheels in the rail position. See Operation - Placing Vehicle On Track.
3. Set the vehicle front wheels straight ahead. Secure the steering wheel using the steering lock. Stop the engine.

Guide Wheel Equipment Alignment Procedure

GUIDE WHEEL TRACK GAUGE - See Figure 3-1

Checking Guide Wheel Track Gauge And Toe-In / Toe-Out

3

1. Measure the track gauge of the front and rear sets of guide wheels on the front and rear guide wheel units. Measure from the back of the left rear wheel flange, directly below the center line of the wheel spindle, to the same point on the right rear wheel flange. Record this dimension (A). Measure from the back of the left front wheel flange, directly below the center line of the wheel spindle, to the same point on the right front wheel flange. Record this dimension (B).
2. Add dimensions (A) and (B) together. Divide the answer (C) by 2 to get the average track gauge of the guide wheel unit. Example: $A + B = C \div 2 = \text{Track Gauge}$.
3. The track gauge must be 53-3/8 to 53-1/2 inches (1356 mm to 1359 mm). Dimensions (A) and (B) must also be equal or within 1/16 inch (1.6 mm). If not, see Adjustment.

Adjusting Track Gauge

1. Unlock and raise the guide wheels. Let the guide wheels rest on the rail. 1/16 inch and 1/8 inch spacers (1) are used on the inside and outside of the swivel bearings (2). Determine the size and number of spacers that need to be moved to obtain the correct track gauge. The same size and number of spacers should be moved on both ends of the axle tube (3).
2. Remove the retaining ring (4). Remove the swivel bearings (2). Move the desired spacers (1) to the inside or outside of the swivel bearing. Replace the swivel bearing (2) on the axle tube (3) with any extra spacers on the outside of the swivel bearing. Secure the swivel bearing with the retaining ring (4).
3. Lower and lock the guide wheels in the rail position. Recheck the track gauge. Repeat the procedure until the track gauge is correct.

Adjusting Toe-In / Toe-Out

1. After adjusting the track gauge, recheck dimensions (A) and (B). Dimensions (A) and (B) must also be equal or within 1/16 inch (1.6 mm). If not, it will be necessary to adjust the toe-in / toe-out.
2. Unlock and raise the guide wheels. Let the guide wheels rest on the rail. Loosen jam nuts (5) and (6) on tie rod (7). Jam nut (5) has left hand threads. Adjust tie rod (7) until dimensions (A) and (B) are equal or within 1/16 inch (1.6 mm). Tighten jam nuts (5) and (6).
3. Lower and lock the guide wheels in the rail position. Recheck the toe-in / toe-out. Repeat the procedure until the toe-in / toe-out is correct.

Guide Wheel Equipment Alignment Procedure

GUIDE WHEEL TRACK GAUGE

FIGURE 3-1
GUIDE WHEEL TRACK GAUGE - REAR UNIT ILLUSTRATED

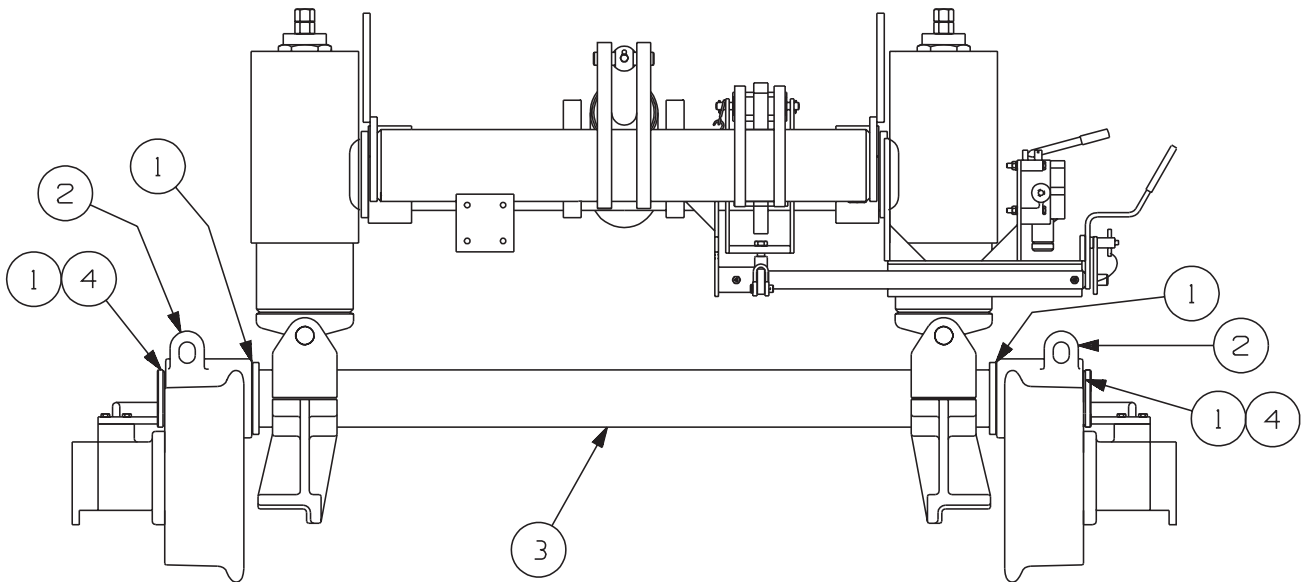
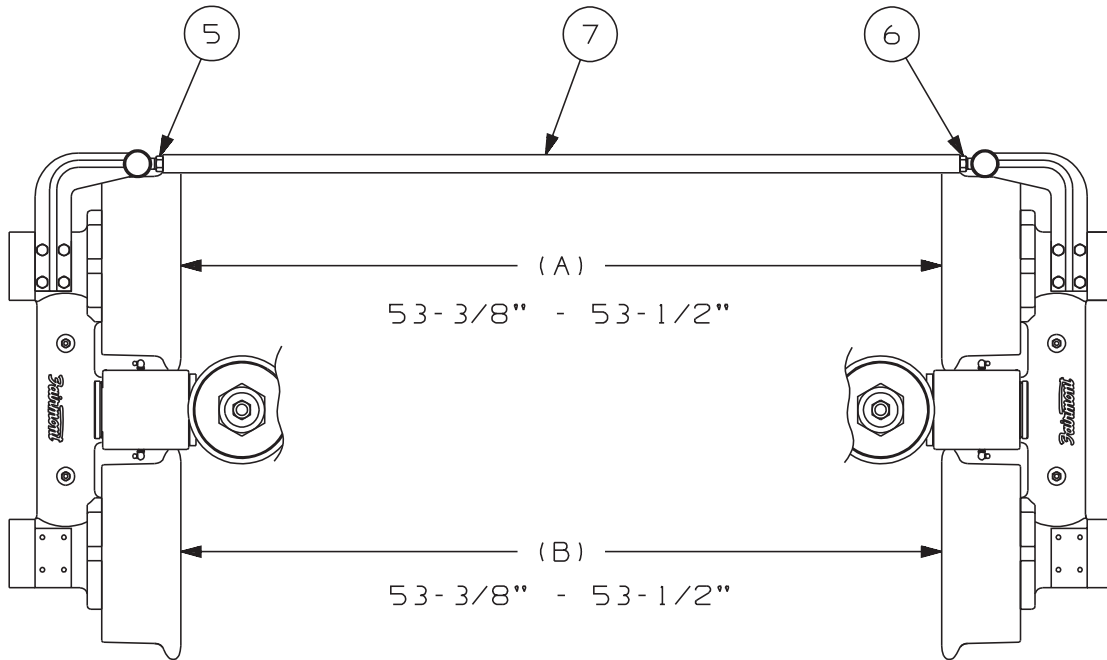

Guide Wheel Equipment Alignment Procedure

GUIDE WHEEL LOAD

Front Guide Wheel Load On Track - See Chart 3-2 and Figure 3-3

3

1. The front guide wheel unit is equipped with two non-adjustable spring cells. Whenever the vehicle is loaded or additional load is added to the existing vehicle load on track, check the load on the front guide wheels. The maximum load on the front guide wheel unit is 14,000 lbs (6,350 kg) or 7,000 LBS (3,175 kg) maximum per side of the guide wheel unit.
2. The protrusion of rod (1) on the spring cell is used to determine the load on the front guide wheels. Measure dimension (L) on both spring cells. See Chart 3-2 to convert dimension (L) to the load on the guide wheel.

CHART 3-2
FRONT GUIDE WHEEL LOAD

DIMENSION (L)		APPROXIMATE LOAD PER SIDE	
1/4"	(6.4 mm)	1940 lbs	(880 kg)
1/2"	(12.7 mm)	3405 lbs	(1544 kg)
3/4"	(19.0 mm)	4865 lbs	(2206 kg)
1"	(25.4 mm)	6330 lbs	(2871 kg)
* 1-1/4"	(31.8 mm)	7795 lbs	(3535 kg)

* **FRONT GUIDE WHEELS ARE OVERLOADED. REDISTRIBUTE OR REMOVE SOME OF THE LOAD. THE MAXIMUM LOAD ON THE FRONT GUIDE WHEEL UNIT IS 14,000 LBS (6,350 kg) OR 7,000 LBS (3,175 kg) MAXIMUM PER SIDE.**

FIGURE 3-3
FRONT SPRING CELL

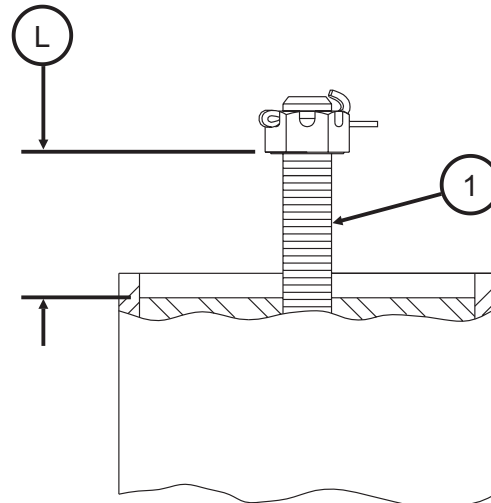

SE90A149A-1

Guide Wheel Equipment Alignment Procedure

GUIDE WHEEL LOAD

Rear Guide Wheel Load On Track - See Figure 3-4 and Chart 3-5

3

1. The rear guide wheel unit is equipped with two adjustable spring cells. The rear guide wheel unit is initially adjusted to carry approximately 50% of the vehicle's rear axle curb weight or a minimum of 5,300 lbs (2,404 kg). The remainder of the weight is carried by the inner dual wheels when the vehicle is on "rail". Whenever the vehicle is loaded or additional load is added to the existing vehicle load on track, check the load on the rear guide wheels. The maximum rated load on the rear guide wheel unit is 13,400 lbs (6,700 kg) or 6,700 lbs (3,039 kg) maximum per side of the guide wheel unit.
2. See Figure 3-4. The protrusion of rod (1) on the spring cell is used to determine the load on the rear guide wheels. Measure dimension (L) on both spring cells. See Chart 3-5 to convert dimension (L) to the load on the guide wheel.

FIGURE 3-4
REAR SPRING CELL

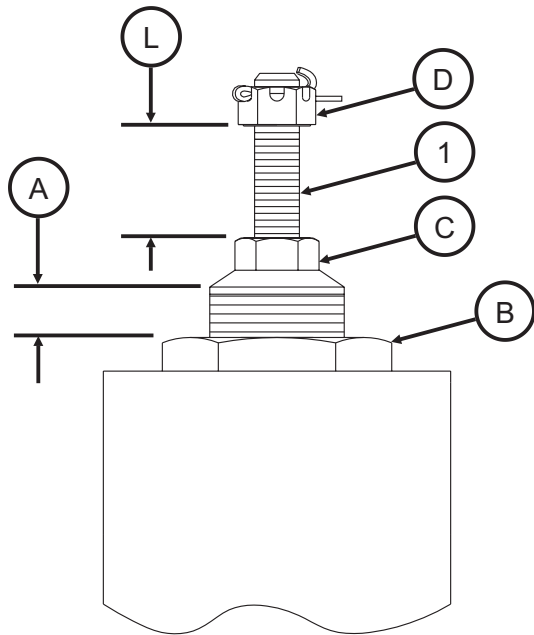

SE90A150A-1

CHART 3-5
REAR GUIDE WHEEL LOAD

DIMENSION (L)		APPROXIMATE LOAD PER SIDE	
1/4"	(6.4 mm)	1200 lbs	(544 kg)
1/2"	(12.7 mm)	1950 lbs	(885 kg)
3/4"	(19.0 mm)	2675 lbs	(1213 kg)
1"	(25.4 mm)	3410 lbs	(1547 kg)
1-1/4"	(31.8 mm)	4140 lbs	(1878 kg)
1-1/2"	(38.1 mm)	4880 lbs	(2214 kg)
1-3/4"	(44.5 mm)	5610 lbs	(2545 kg)
2"	(50.8 mm)	6345 lbs	(2878 kg)
* 2-1/4"	(57.2 mm)	7080 lbs	(3211 kg)

- * **REAR GUIDE WHEELS ARE OVERLOADED. REDISTRIBUTE OR REMOVE SOME OF THE LOAD. THE MAXIMUM LOAD ON THE REAR GUIDE WHEEL UNIT IS 13,400 LBS (6,078 kg) OR 6,700 LBS (3,039 kg) MAXIMUM PER SIDE.**

Note: Permanent attachments to the vehicle such as a tool box, utility box, crane, aerial lift boom, etc. which could cause uneven loading on the rear guide wheels should be compensated for by modifying the vehicle suspension by adding leaf springs, coil springs, torsion bars, etc. Do not adjust the rear guide wheel unit spring cells to compensate for permanent attachments.

Guide Wheel Equipment Alignment Procedure

GUIDE WHEEL LOAD

Adjusting Rear Guide Wheel Load - See Figure 3-4 and Chart 3-5

1. The recommended rear guide wheel unit load setting is approximately 50% of the vehicle rear axle weight or 5,300 lbs (2,404 kg) minimum.
2. To calculate the load setting for each rear spring cell, use the following formula:
$$\text{Vehicle Rear Axle Weight} \times 25 \% (0.25) = \text{Spring Cell Load}$$
3. Convert the calculated spring cell load into dimension (L). See Rear Guide Wheel Load Chart 3-5. If the calculated spring cell load (dimension L) is less than 3/4 inch (19 mm), the spring cell (dimension L) must be set to a minimum of 3/4 inch (19 mm).
4. Unlock and raise the rear guide wheels. Let the guide wheels rest on the rails.
5. Dimension (A), the length of the large threaded stud extending from the top of lock nut (B) to the top of the threads on adjusting nut (C), is preset at the factory to 3/4 inch (19 mm). This allows approximately equal adjustment up or down. If dimension (A) is not initially set to 3/4 inch (19 mm) on both spring cells, loosen lock nut (B). Turn adjusting nut (C) until dimension (A) is set to 3/4 inch (19 mm) on both spring cells. Re-tighten lock nut (B).
6. Lower and lock the rear guide wheels in the "rail" position.
7. Measure dimension (L), the distance from the top of adjusting nut (C) to the bottom of castle nut (D). See Rear Guide Wheel Load Chart 3-5 to convert dimension (L) to the load. The spring cell must be set to the calculated load dimension (L) or minimum load dimension (L), see Step 3.
8. To adjust the spring cell load, unlock and raise the rear guide wheels. Let the guide wheels rest on the rails. Loosen lock nut (B). Turn adjusting nut (C) clockwise to increase the load on the guide wheels or counter-clockwise to decrease the load on the guide wheels.
9. Lower and lock the rear guide wheels in the "rail" position. Re-measure dimension (L). See Rear Guide Wheel Load Chart 3-5 to convert dimension (L) to the load on the guide wheels.
10. Repeat Steps 8 and 9 until dimension (L) corresponds to the calculated load or minimum load on the spring cell, see Step 3. Tighten lock nut (B). Both spring cells must be set to the same dimension (A) within 1/8 inch (3.2 mm).
11. If the spring cell cannot be adjusted to the calculated load or the minimum load, the rear guide wheel unit must be repositioned in a different set of mounting holes.

Guide Wheel Equipment Alignment Procedure

FIGURE 3-6
GUIDE WHEEL EQUIPMENT ALIGNMENT

3

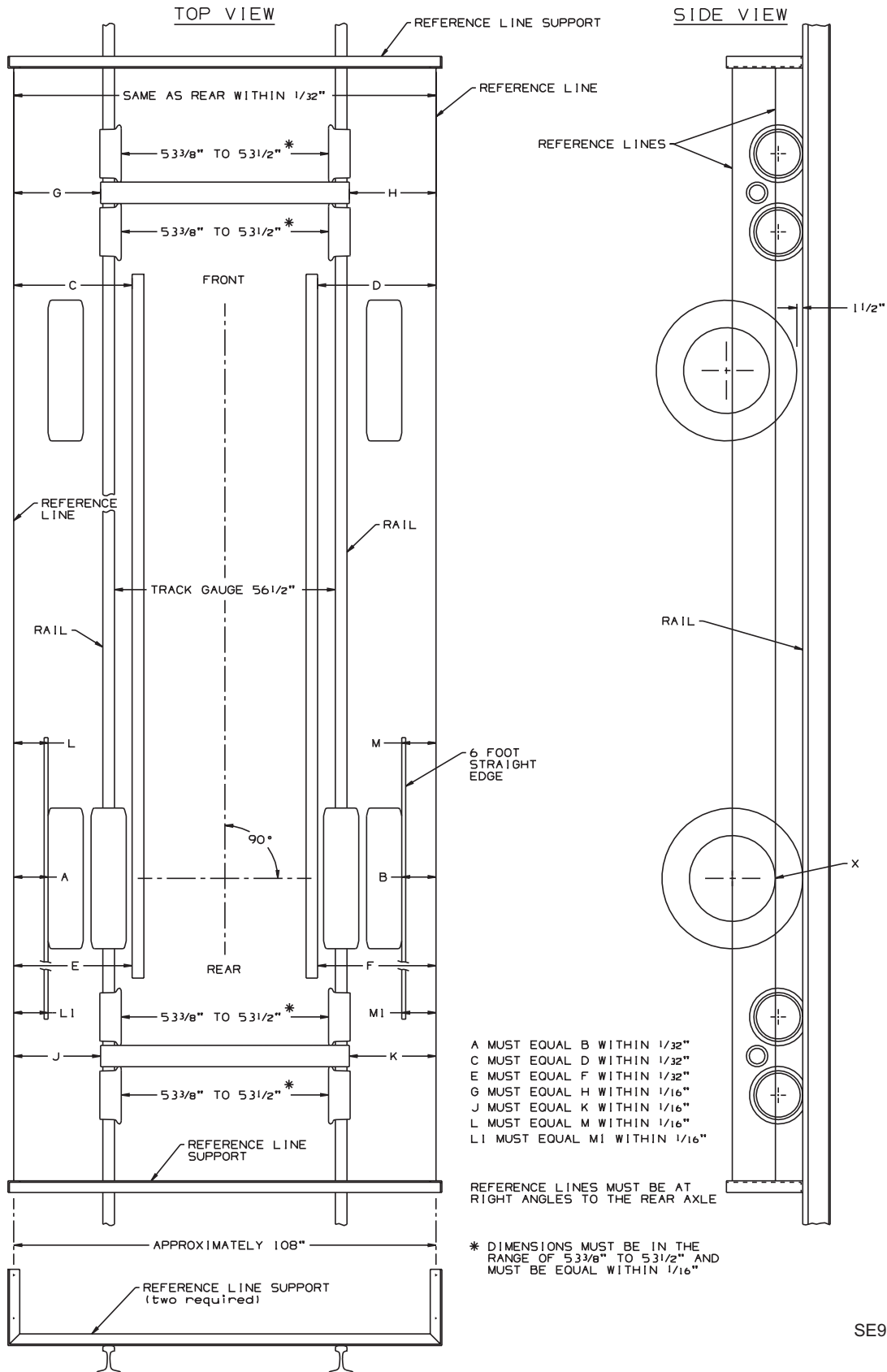

Guide Wheel Equipment Alignment Procedure

STRING LINING SET-UP - See Figure 3-6

1. The string lining procedure is only a guide to check and make alignment adjustments to the guide wheel equipment. String lining the vehicle and guide wheel equipment will not guarantee that the guide wheel equipped vehicle will track properly. Harsco Track Technologies recommends that all HY-RAIL® equipped vehicles be track tested. The vehicle should be at its normal operating load for track testing. The vehicle should be track tested when:
 - a. The guide wheel equipment is installed on the vehicle.
 - b. Any adjustments are made to the guide wheel equipment.
 - c. The load on the vehicle is changed.
 - d. Periodically to ensure that the vehicle is tracking properly.
2. Lower and lock the front and rear guide wheel units in the "rail" position. See Operation - Placing Vehicle On Track.
3. Establish parallel reference lines on each side of the vehicle as shown in Figure 3-6. Parallel reference lines can be established by building two supports or brackets. These can be built out of scrap angle iron or other material. The supports must be high enough so the top reference line is through the center of the rear axle. The supports need to be a few inches longer than the width of the vehicle. Wires or cords stretched between the front and rear supports will be the reference lines. The wires or cords should be spaced approximately 108 inches (2.74 m) apart. The distance between the wires or cords must be equal or within 1/32 inch (.8 mm) at each support.
4. Clamp the supports to the rail in front of and behind the vehicle. The supports should be at right angles to the rail. Stretch the wires or cords between the supports, so the lower reference line is level with the bottom edge of the rear vehicle wheel rim(s) (point X) and the upper reference line is through the center of the rear axle(s). The reference lines must be level.
5. Shift the supports on the rail until dimension A equals (=) B and dimension C equals (=) D or within 1/32 inch (.8 mm). Measurements A and B should be taken from the edge of the rear vehicle rim(s) directly below the axle (point X) to the reference lines. Measurements C and D are taken from the front of the vehicle frame. When shifting the supports, keep them at right angles to the rail so the reference lines stay level and parallel to each other.
6. Hold a six (6) foot straight edge against the outer edge of the rear, outside tires with the straight edge centered on the tires. Record dimensions L, L1, M and M1 to the reference line. Rotate the rear tires 180 degrees and record a second set of dimensions at L, L1, M and M1. Average the two dimensions taken at L, L1, M and M1.

Example: [L (first dimension) + L (second dimension)] ÷ 2 = L (average dimension)

Guide Wheel Equipment Alignment Procedure

STRING LINING SET-UP - See Figure 3-6

7. Shift the supports on the rail until dimension L (average) equals (=) M (average) and dimension L1 (average) equals (=) M1 (average) or are within 1/16 inch (1.6 mm). When shifting the supports, keep them at right angles to the rail so the reference lines stay level and parallel to each other. The reference lines will be parallel only when the rear axle is straight.
9. After the reference lines have been established, measurements can be taken from these lines to the guide wheels to help ensure correct alignment.

GUIDE WHEEL ALIGNMENT - See Figures 3-6 and 3-7

Checking Guide Wheel Alignment

1. Take measurements G, H, J and K. Measure from the outer edge of the axle tubes (2) to the reference lines. Check that dimension G equals (=) H and J equals (=) K or are within 1/16 inch (1.6 mm). If not, see Adjustment.

Adjusting Guide Wheel Alignment

1. Unlock and raise the front and / or rear guide wheels front the rail position. Let the guide wheels rest on the rail.
2. Loosen the bolts that secure axle clamps (1). Shift the axle tube (2) until dimension G equals (=) H and / or J equals (=) K or are within 1/16 inch (1.6 mm). Tighten the bolts to secure the axle tube (2) in the axle clamps (1).
3. Lower and lock the guide wheels in the rail position. Re-check dimensions G and H, and J and K.
4. Repeat the adjustment procedure until dimension G equals (=) H and / or J equals (=) K or are within 1/16 inch (1.6 mm).

Guide Wheel Equipment Alignment Procedure

GUIDE WHEEL ALIGNMENT

FIGURE 3-7
GUIDE WHEEL ALIGNMENT - REAR UNIT ILLUSTRATED

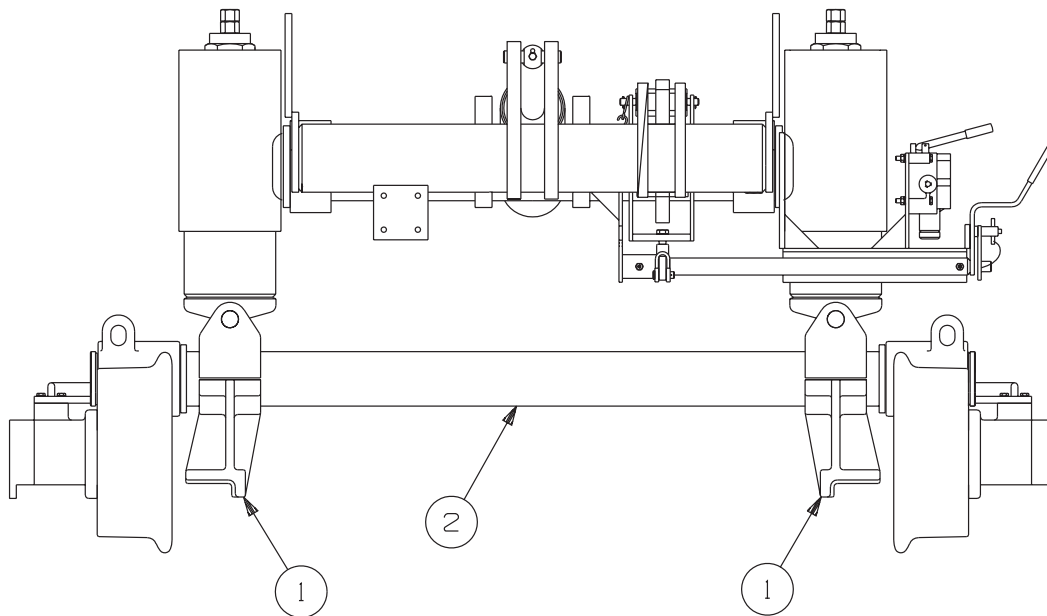

SE02A162A-1

Guide Wheel Equipment Alignment Procedure

VEHICLE TRACK TEST

3



■ **CHECK AND CORRECT ALIGNMENT PROMPTLY IF MISALIGNMENT IS INDICATED. MISALIGNMENT OF GUIDE WHEEL EQUIPMENT COULD RESULT IN DERAILMENT OF THE VEHICLE AND SEVERE BODILY INJURY.**

1. Harsco Track Technologies recommends that all HY-RAIL® equipped vehicles be track tested. The vehicle should be at its normal operating load for track testing. The vehicle should be track tested when:
 - a. The guide wheel equipment is installed on the vehicle.
 - b. Any adjustments are made to the guide wheel equipment.
 - c. The load on the vehicle is changed.
 - d. Periodically to ensure that the vehicle is tracking properly.
2. The vehicle must be placed on straight, level, tangent track. See Operation Section - Placing Vehicle On Track.
3. Apply spray paint to the flanges and treads of all guide wheels.
4. Lower and lock both guide wheel units in the "rail" position.
5. Operate the vehicle for a short distance at a normal operating speed.
6. The paint should wear evenly around the flanges and treads of all guide wheels. If the paint is worn evenly on all guide wheels, the vehicle and guide wheel equipment is properly aligned.
7. If the paint wore off the right front guide wheel flanges and not off the left front guide wheel flanges, the guide wheel unit is "flanging right".
 - a. Unlock and raise the front guide wheels from the "rail" position. Let the guide wheels rest on the rail. Loosen the bolts that secure the axle clamps and slightly shift the axle tube assembly to the left. Re-tighten the bolts that secure the axle clamps.
 - b. Repaint the flanges and treads on all guide wheels. Lower and lock the guide wheel unit in the "rail" Position. Operate the vehicle for a short distance at a normal operating speed. If the paint is worn evenly on all guide wheels, the vehicle and guide wheel equipment is properly aligned.
 - c. If the paint continues to wear off the right front guide wheel flange and not off the left front guide wheel flange, repeat Steps a. & b. If the guide wheel unit is adjusted to the limit of the axle tube assembly, go to Step 9.

Guide Wheel Equipment Alignment Procedure

VEHICLE TRACK TEST

8. If the paint wore off the left front guide wheel flange and not off the right front guide wheel flange, the guide wheel unit is "flanging left".
 - a. Unlock and lower the front of the vehicle from the "rail" position. Let the guide wheels rest on the rail. Loosen the bolts that secure the axle clamps and slightly shift the axle tube assembly to the right. Re-tighten the bolts that secure the axle clamps.
 - b. Repaint the flanges and treads on all guide wheels. Lower and lock the guide wheels in the "rail" Position. Operate the vehicle for a short distance at a normal operating speed. If the paint is worn evenly on all guide wheels, the vehicle and guide wheel equipment is properly aligned.
 - c. If the paint continues to wear off the left front guide wheel flange and not off the right front guide wheel flange, repeat Steps a. & b. If the guide wheel unit is adjusted to the limit of the axle tube assembly, go to Step 9.
9. Note which guide wheels, flange and/or tread the paint is worn on.
 - a. Repaint the flanges and treads on all guide wheels.
 - b. Operate the vehicle in reverse for a short distance at a normal operating speed.
 - c. Note which guide wheels, flange and/or tread the paint is worn on.

If the paint wore off the right front flanges when traveling forward and then off the left rear flanges when traveling in reverse or off the left front flanges when traveling forward and then off the right rear flanges when traveling in reverse, the vehicle is probably not aligned properly. Have the frame checked for proper alignment. See Vehicle Check.
10. If the vehicle continues to track improperly, repeat the String Lining and Guide Wheel Alignment Procedure.

Adjustments

VEHICLE FRONT TIRE CLEARANCE - RAIL POSITION

The vehicle's front tire clearance should be checked whenever the vehicle is placed on rail or whenever the load on the vehicle is changed significantly.

3

Checking Vehicle Front Tire Clearance - Rail Position - See Figure 3-8

1. Place the vehicle on straight, level, tangent track. Place the vehicle automatic transmission in "Park" or manual transmission in "Neutral". Apply the parking brake. Lower and lock both guide wheel units in the "rail" position. See Operation Section - Placing Vehicle On Track.
2. When the front guide wheels are lowered and locked in the "rail" position, the axle hooks will raise the vehicle's front tires above the rails. This is necessary to ensure clearance when the vehicle passes through switches, turnouts, crossings, frogs, etc. As the vehicle is loaded, the front tire clearance will decrease. The front tires must always clear the top of the rails by a minimum of 1-1/2 inches (38 mm) whenever the vehicle is on track. If not, see Adjustment.

Adjustment - See Figure 3-8

1. Unlock and raise the front guide wheels to lower the front of the vehicle to the ground. Loosen and remove the two flange nuts and cap screws (1). Reposition the lower part (2) of the two piece axle hook to a different pair of holes in the upper part (3) of the hook assembly. Reinstall and tighten the two flange nuts and cap screws (1). Repeat this procedure to adjust the other axle hook. Both axle hooks must be adjusted to maintain the minimum vehicle front tire to rail clearance for both front tires.
2. Lower and lock the front guide wheels in the "rail" position. Recheck the vehicle front tire clearance. If necessary, repeat the adjustment procedure until the minimum of 1-1/2 inches (38 mm) of clearance is obtained.
3. If the front axle hooks cannot be adjusted to obtain the 1-1/2 inch (38 mm) minimum clearance, the guide wheel unit must be repositioned in a different set of mounting holes or different axle hooks must be applied to the vehicle. For axle hook replacement, contact Harsco Track Technologies, Harsco Corporation, Fairmont, Minnesota.

Adjustments

VEHICLE FRONT TIRE CLEARANCE - RAIL POSITION

FIGURE 3-8
VEHICLE FRONT TIRE CLEARANCE

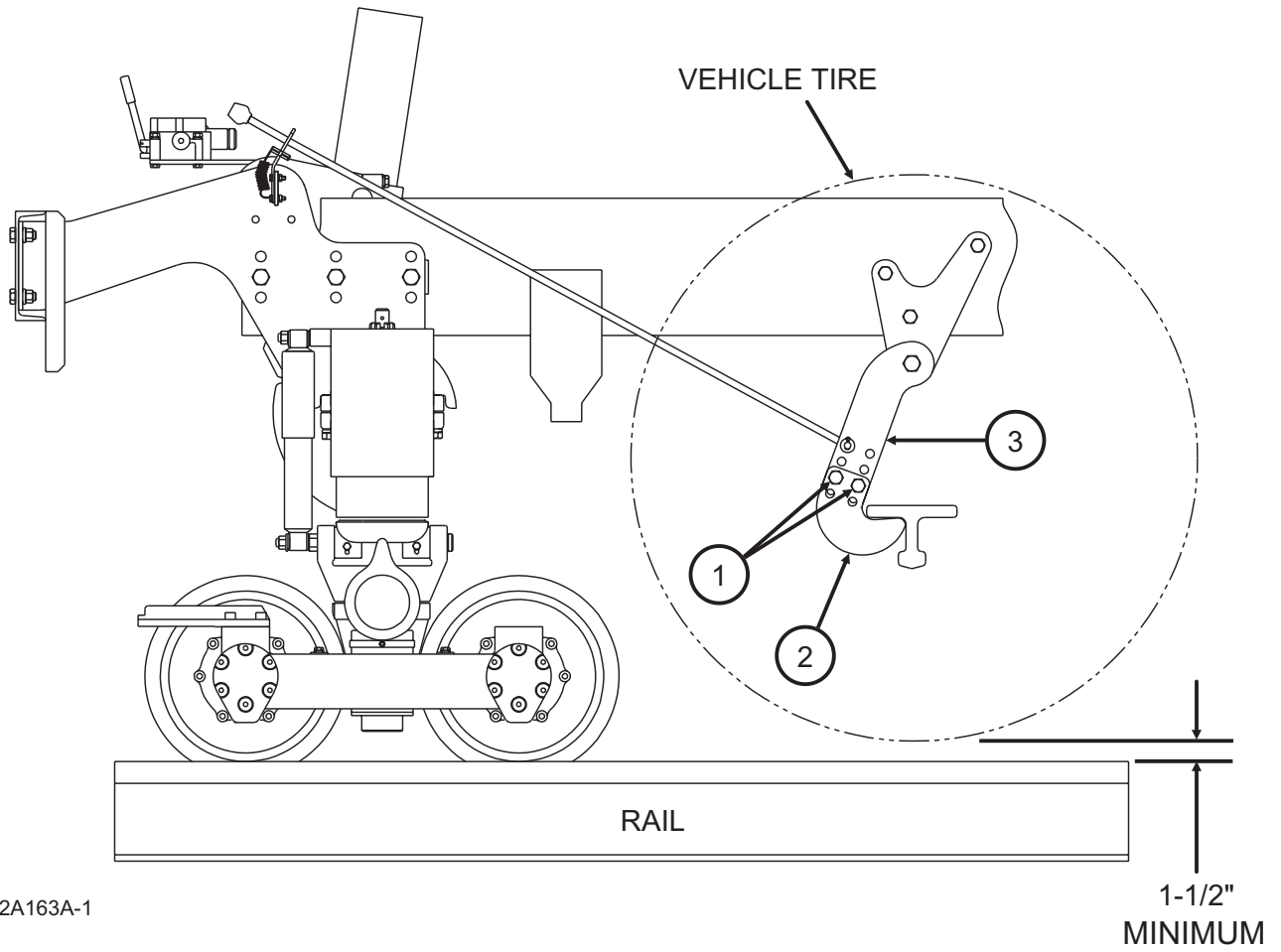

SE02A163A-1

Adjustments

AXLE HOOK CLEARANCE - HIGHWAY POSITION

The axle hook clearance should be checked whenever adjustments are made to the guide wheel unit or whenever the load on the vehicle is changed significantly.

3

Park the vehicle on solid level ground. The vehicle must be loaded with its normal operating load. Place the vehicle automatic transmission in "Park" or manual transmission in "Neutral". Apply the parking brake. Stop the engine.

Note: On some vehicle applications the axle hooks may be reversed and will engage under the axle from the rear instead of from the front as illustrated. This will cause the axle hook control rod to engage and disengage the axle hooks in the opposite direction.

Checking Axle Hook Clearance - Highway Position - See Figure 3-9

1. Measure the distance from the "toe" of both axle hooks (1) to the axle (2). The minimum clearance between the axle hook "toe" and the axle is 3/4 inch (19 mm).
2. Both axle hooks must be adjusted to obtain equal clearance from the axle. If the axle hook clearance is incorrect, see Adjustment.

Adjustment - See Figure 3-9

1. To adjust the axle hooks, position the axle hook control rod (3) so the axle hook is at least 3/4 inch (19 mm) away from the axle. Loosen set screw (4) on collar (5). Slide collar (5) tight against plate (6). Tighten set screw (4).
2. Repeat this procedure to adjust the axle hook clearance for the other axle hook.

Adjustments

AXLE HOOK CLEARANCE - HIGHWAY POSITION

FIGURE 3-9
AXLE HOOK CLEARANCE

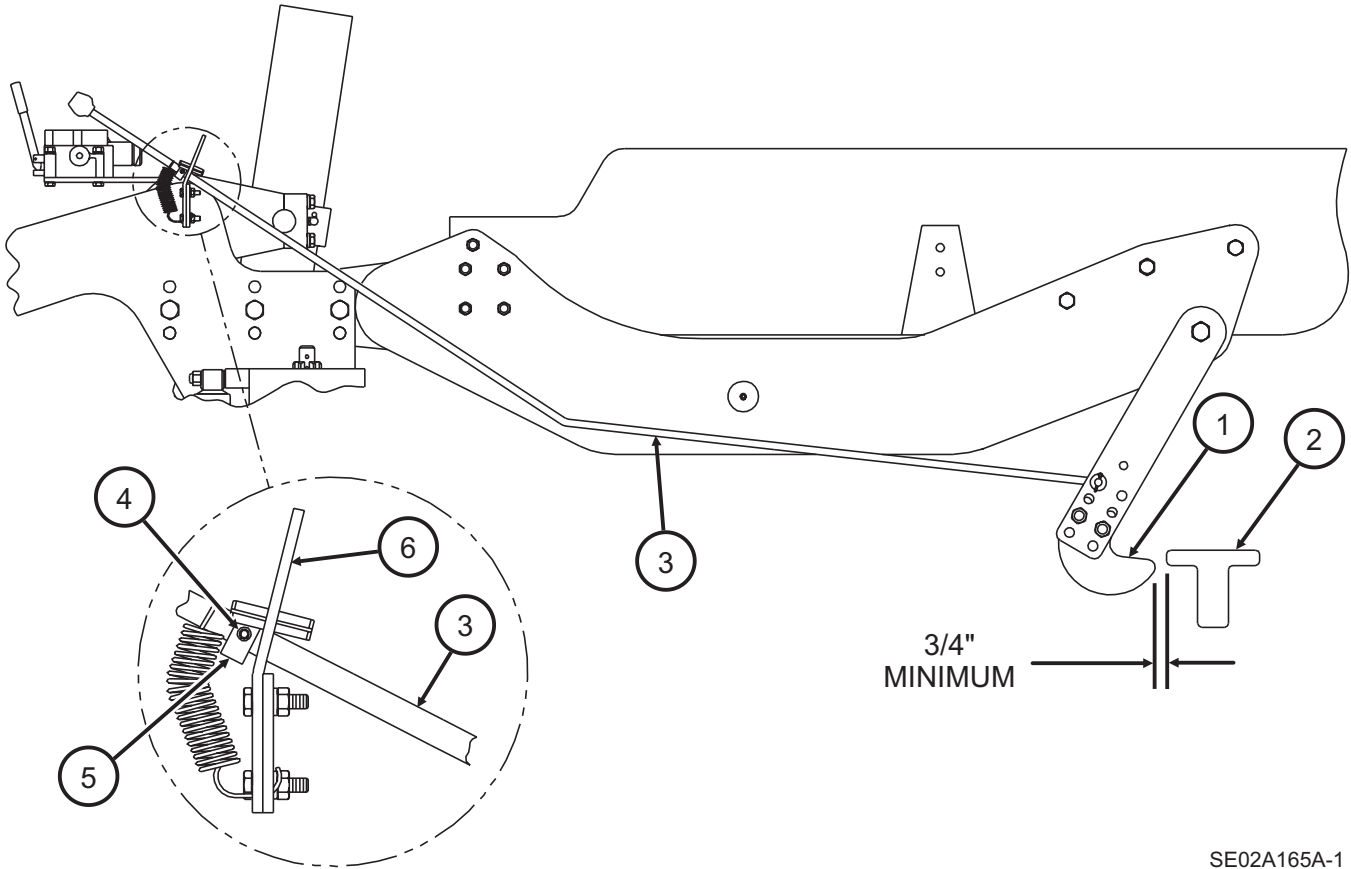

SE02A165A-1

Adjustments

FRONT GUIDE WHEEL UNIT LOCK ADJUSTMENT - See Figure 3-10

3

1. The vehicle must be on level track. Place the vehicle automatic transmission in "Park" or manual transmission in "Neutral". Apply the parking brake. Lower and lock the guide wheels in the "rail" position. See Operation Section - Placing Vehicle On Track.
2. Both the front guide wheel unit spring cell suspension tubes must be perpendicular ($90^\circ \pm 1^\circ$) to the rail when the vehicle is on rail. Proper adjustment of the spring cell tubes will allow the spring cell suspension to operate correctly.
3. Place a bubble level against the front or rear of the spring cell suspension. If the spring cell suspension tubes are not perpendicular ($90^\circ \pm 1^\circ$) to the rail, the stop set screws and lock will need to be adjusted.
4. Determine the approximate amount of adjustment required. Unlock and raise the guide wheels from the rail. Let the guide wheels rest on the rails.
5. Turn adjusting screws (1) clockwise or counter-clockwise as needed. Adjust both set screws equally so they both bear against the lock surface (2). Lower and lock the guide wheels on the rail.
6. Using the bubble level, re-check to see if the spring cell suspension tube is perpendicular to the rail (90 degrees). If necessary, repeat Steps 4 and 5 until the guide wheel unit spring cell suspension tubes are perpendicular ($90^\circ \pm 1^\circ$) to the rail.
7. After adjusting the spring cell tube to perpendicular, check the lock arm engagement. The lock arm (3) should engage into the lock plate (4) easily but without more than 1/16 inch clearance.
8. If the lock arm (3) will not engage into the lock plate (4), material can be ground off the lock arm until it will engage into the lock plate.
9. If the lock arm (3) engages the lock plate (4) but there is more than 1/16 inch clearance between the lock arm and the lock plate, a spacer will need to be welded on the lock arm to reduce the clearance to 1/16 inch or less.
10. After checking and adjusting the lock in the rail position, raise and lock the guide wheels in the highway position. The lock arm (3) should engage into the lock plate (4) easily but without more than 1/16 inch clearance.
11. If necessary, adjust set screws (5), remove material or weld a spacer on lock arm (3) so it engages into the lock plate (4) easily but without more than 1/16 inch clearance. Adjust set screws (5) equally so they both bear against the lock surface (6).

Adjustments

FIGURE 3-10
FRONT GUIDE WHEEL UNIT LOCK ADJUSTMENT

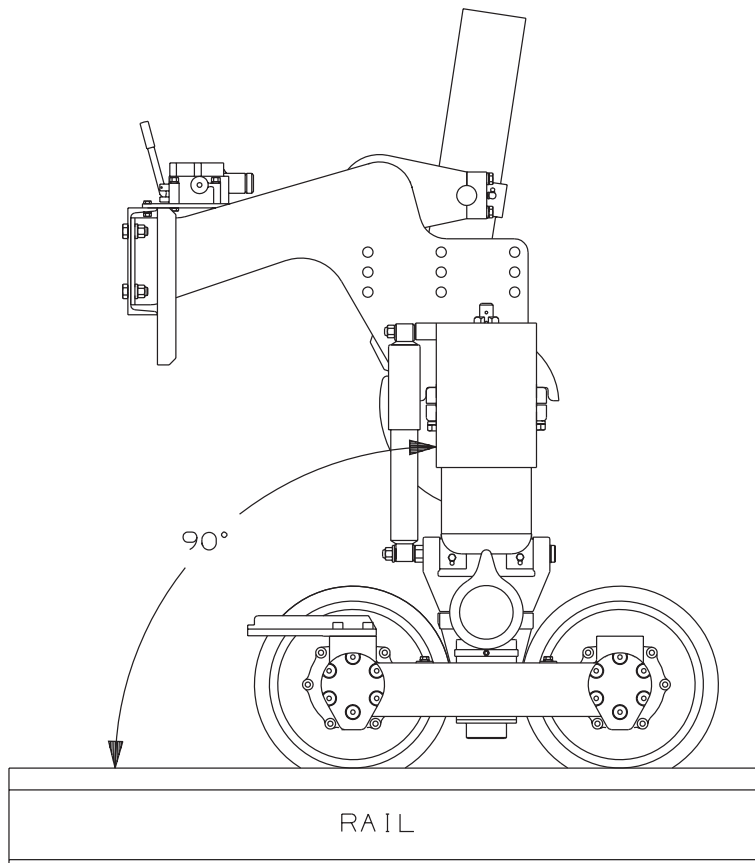
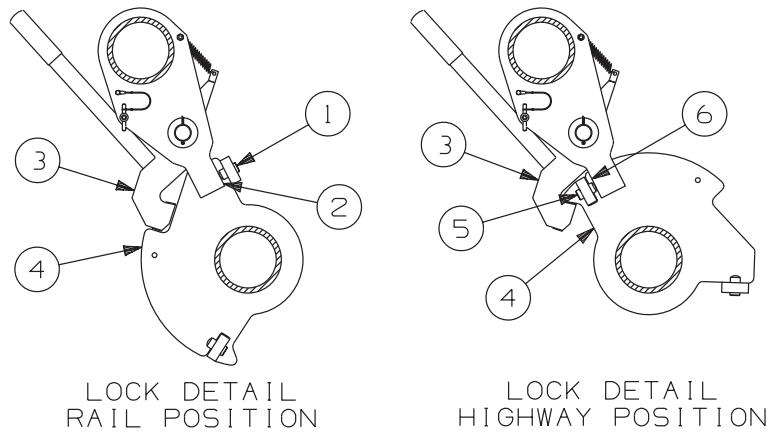

Adjustments

REAR GUIDE WHEEL UNIT LOCK ADJUSTMENT - See Figure 3-11

3

1. The vehicle must be on level track. Place the vehicle automatic transmission in "Park" or manual transmission in "Neutral". Apply the parking brake. Lower and lock the guide wheels in the "rail" position. See Operation Section - Placing Vehicle On Track.
2. Both the rear guide wheel unit spring cell suspension tubes must be perpendicular ($90^\circ \pm 1^\circ$) to the rail when the vehicle is on rail. Proper adjustment of the spring cell tubes will allow the spring cell suspension to operate correctly.
3. Place a bubble level against the front or rear of the spring cell suspension. If the spring cell suspension tubes are not perpendicular ($90^\circ \pm 1^\circ$) to the rail, the stop set screws and lock will need to be adjusted.
4. Determine the approximate amount of adjustment required. Unlock and raise the guide wheels from the rail. Let the guide wheels rest on the rails.
5. Turn adjusting screws (1) clockwise or counter-clockwise as needed. Adjust both set screws equally so they both bear against the lock surface (2). Lower and lock the guide wheels on the rail.
6. Using the bubble level, re-check to see if the spring cell suspension tube is perpendicular to the rail (90 degrees). If necessary, repeat Steps 4 and 5 until the guide wheel unit spring cell suspension tubes are perpendicular ($90^\circ \pm 1^\circ$) to the rail.
7. After adjusting the spring cell tube to perpendicular, check the lock arm engagement. The lock arm (3) should engage into the lock plate (4) easily but without more than 1/16 inch clearance.
8. If the lock arm (3) will not engage into the lock plate (4), material can be ground off the lock arm until it will engage into the lock plate.
9. If the lock arm (3) engages the lock plate (4) but there is more than 1/16 inch clearance between the lock arm and the lock plate, a spacer will need to be welded on the lock arm to reduce the clearance to 1/16 inch or less.
10. After checking and adjusting the lock in the rail position, raise and lock the guide wheels in the highway position. The lock arm (3) should engage into the lock plate (4) easily but without more than 1/16 inch clearance.
11. If necessary, adjust set screws (5), remove material or weld a spacer on lock arm (3) so it engages into the lock plate (4) easily but without more than 1/16 inch clearance. Adjust set screws (5) equally so they both bear against the lock surface (6).

Adjustments

FIGURE 3-11
REAR GUIDE WHEEL UNIT LOCK ADJUSTMENT

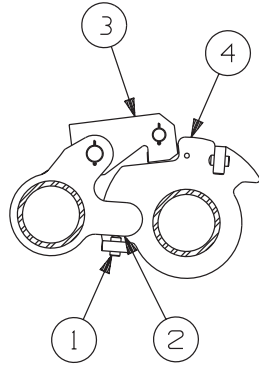

LOCK DETAIL
RAIL POSITION

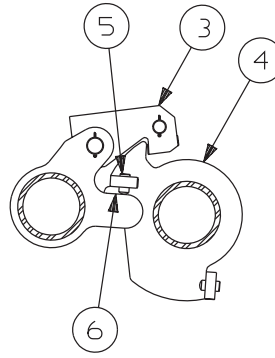

LOCK DETAIL
HIGHWAY POSITION

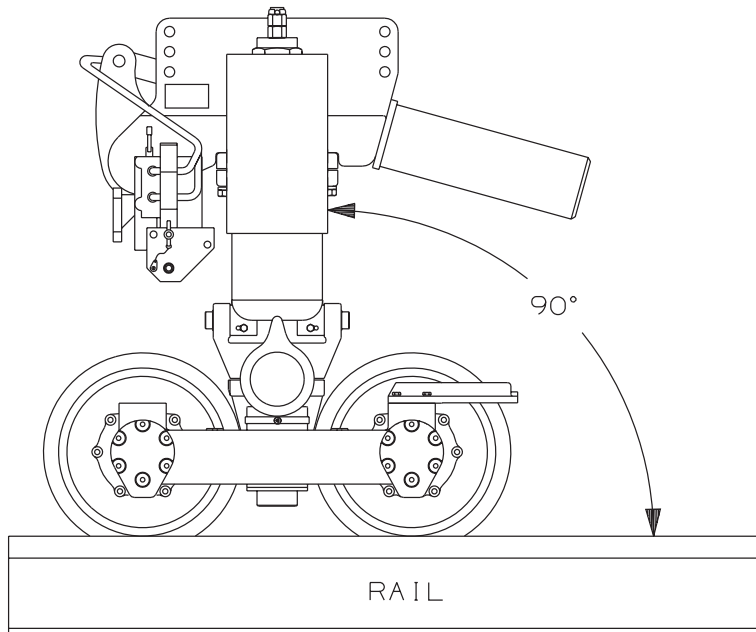

SE02A167A-1

Adjustments

RAIL SWEEP CLEARANCE

Checking Rail Sweep Clearance - See Figure 3-12

3

The guide wheel units may be equipped with rail sweeps.

1. Place the vehicle on straight, level track. Place the vehicle automatic transmission in "Park" or manual transmission in "Neutral". Apply the parking brake. Lower and lock the front and rear guide wheels in the "rail" position.
2. The rubber rail sweeps should clear the top of the rail by 1/8 inch (3.2 mm). If not, see Adjustment.

Adjustment - See Figure 3-12

1. Loosen the two hex nuts on cap screws (2). Slide the rubber sweep (1) down until it clears the top of the rail by 1/8 inch (3.2 mm). Re-tighten the two hex nuts and cap screws (2).
2. Repeat this procedure to adjust the rail sweep clearance on the other guide wheels.
3. When the rubber sweep (1) is worn so it cannot be adjusted, replace the rubber sweep.

FIGURE 3-12
RAIL SWEEP CLEARANCE

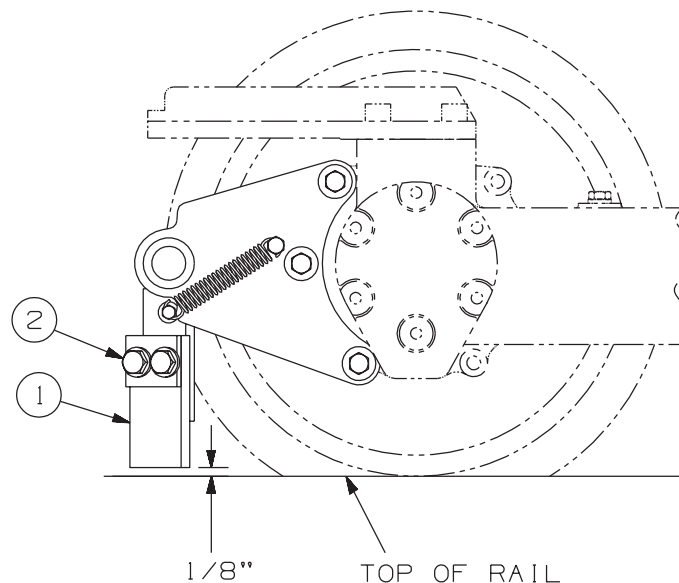

SE140142A-4

Adjustments

BRAKE SHOE CLEARANCE

See the Maintenance Section - Brake Shoe Replacement And Adjustment.

Adjustments

FRONT GUIDE WHEEL UNIT HYDRAULIC PRESSURE

Note: Hydraulic pressure settings are preset at the factory and should not be changed unless an operation malfunction indicates an incorrect pressure setting. It is very important that any pressure gauge being used is accurate and sized properly. Hydraulic pressure checks and adjustments must be with the pump at no flow. An incorrectly adjusted pressure setting could cause system damage.

3

Checking Control Valve Relief Pressure - See Figure 3-13

1. Attach the provided pressure gauge (099137K) to test port (1) on the front guide wheel unit control valve.
2. Start the vehicle engine. Place the vehicle automatic transmission in "Park" or manual transmission in "Neutral". Apply the parking brake. Engage the mechanical PTO hydraulic pump or start the auxiliary hydraulic power source. If the vehicle is equipped with an auxiliary control valve, place the valve in the proper position to direct hydraulic oil flow to the guide wheel equipment.
3. Do not release the guide wheel unit locking mechanism. Push the control valve handle (2) towards the control valve to bottom out the hydraulic cylinder against the locking mechanism. Hold the control valve handle in this position while reading the hydraulic pressure on the gauge. Release the control valve handle.
4. If the hydraulic pressure indicated is 2200 PSI (152 bar), the control valve relief pressure is set correctly. Disengage the mechanical PTO hydraulic pump or stop the auxiliary hydraulic power source. Remove the pressure gauge from test port (1).
5. If the pressure indicated is not 2200 PSI (152 bar), go to Adjustment.

Adjusting Control Valve Relief Pressure - See Figure 3-13

1. Remove the relief valve cap (3) from the control valve to expose the adjusting screw.
2. Do not release the guide wheel unit locking mechanism. Push control valve handle (2) towards the control valve to bottom out the hydraulic cylinder against the locking mechanism. Hold the control valve handle in this position while adjusting and reading the hydraulic pressure on the gauge.
3. Turn the adjusting screw clockwise to increase the pressure or counter-clockwise to decrease the pressure. Stop when the pressure gauge remains steady at a constant pressure of 2200 PSI (152 bar). Release the control valve handle.
4. Disengage the mechanical PTO hydraulic pump or stop the auxiliary hydraulic power source. Remove the pressure gauge from test port (1). Install the relief valve cap (3).
5. If a constant pressure of 2200 PSI (152 bar) cannot be obtained at the control valve, the flow divider valve may have to be adjusted. See Flow Divider Valve Hydraulic Pressure.

Adjustments

FRONT GUIDE WHEEL UNIT HYDRAULIC PRESSURE

FIGURE 3-13
FRONT GUIDE WHEEL UNIT HYDRAULIC
PRESSURE ADJUSTMENT

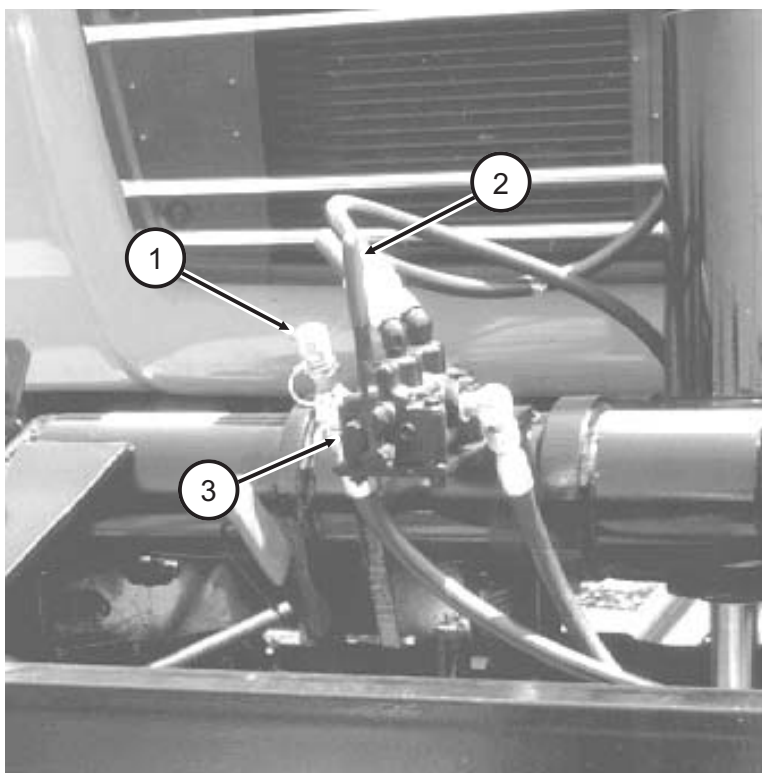

02-159

Adjustments

REAR GUIDE WHEEL UNIT HYDRAULIC PRESSURE

Checking Control Valve Relief Pressure - See Figure 3-14

3

1. Attach the provided pressure gauge (099137K) to test port (1) on the rear guide wheel unit control valve.
2. Start the vehicle engine. Place the vehicle automatic transmission in "Park" or manual transmission in "Neutral". Apply the parking brake. Engage the mechanical PTO hydraulic pump or start the auxiliary hydraulic power source. If the vehicle is equipped with an auxiliary control valve, place the valve in the proper position to direct hydraulic oil flow to the guide wheel equipment.
3. Do not release the guide wheel unit locking mechanism. Push control valve handle (2) towards the control valve to bottom out the hydraulic cylinder against the locking mechanism. Hold the control valve handle in this position while reading the hydraulic pressure on the gauge. Release the control valve handle.
4. If the hydraulic pressure indicated is 1800 PSI (124 bar), the control valve relief pressure is set correctly. Disengage the mechanical PTO hydraulic pump or stop the auxiliary hydraulic power source. Remove the pressure gauge from test port (1).
5. If the pressure indicated is not 1800 PSI (124 bar), go to Adjustment.

Adjusting Control Valve Relief Pressure - See Figure 3-14

1. Remove the relief valve cap (3) from the control valve to expose the adjusting screw.
2. Do not release the guide wheel unit locking mechanism. Push the control valve handle (2) towards the control valve to bottom out the hydraulic cylinder against the locking mechanism. Hold the control valve handle in this position while adjusting and reading the hydraulic pressure on the gauge.
3. Turn the adjusting screw clockwise to increase the pressure or counter-clockwise to decrease the pressure. Stop when the pressure gauge remains steady at a constant pressure of 1800 PSI (124 bar). Release the control valve handle.
4. Disengage the mechanical PTO hydraulic pump or stop the auxiliary hydraulic power source. Remove the pressure gauge from test port (1). Install the relief valve cap (3).
5. If a constant pressure of 1800 PSI (124 bar) can not be obtained at the control valve, the flow divider valve may have to be adjusted. See Flow Divider Valve Hydraulic Pressure.

Adjustments

REAR GUIDE WHEEL UNIT HYDRAULIC PRESSURE

FIGURE 3-14
FRONT GUIDE WHEEL UNIT HYDRAULIC
PRESSURE ADJUSTMENT

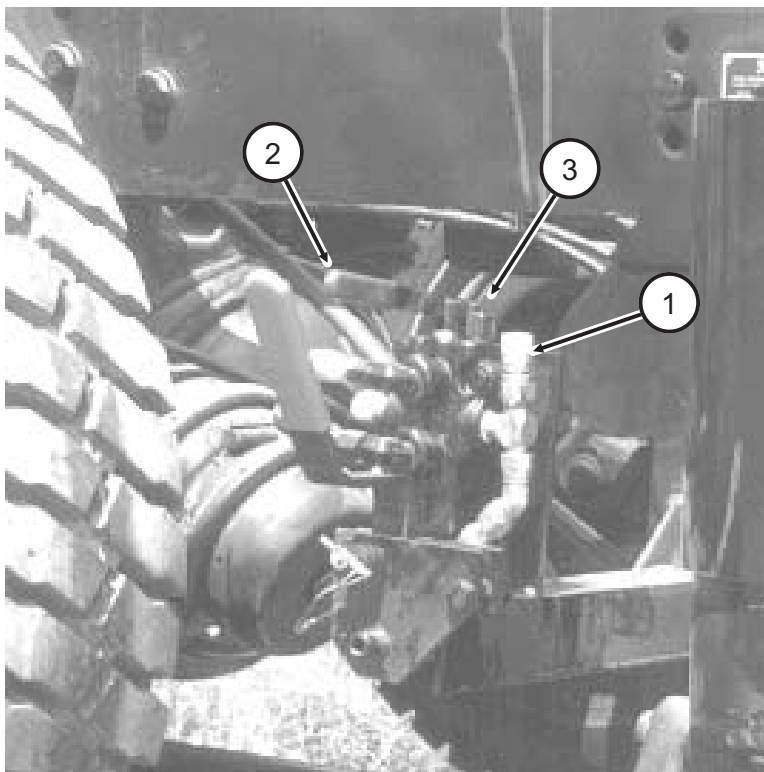

02-160

Adjustments

FLOW DIVIDER VALVE HYDRAULIC PRESSURE

Note: The flow divider valve is preset from the factory to 2500 PSI (172 bar).

3

Checking Flow Divider Valve Relief Pressure - See Figure 3-13

1. Attach the provided pressure gauge (099137K) to the test port (1) on the front guide wheel unit control valve.
2. Remove the relief valve cap (3) from the control valve, to expose the adjusting screw.
3. Start the vehicle engine. Place the vehicle automatic transmission in "Park" or manual transmission in "Neutral". Apply the parking brake. Engage the mechanical PTO hydraulic pump or start the auxiliary hydraulic power source. If the vehicle is equipped with an auxiliary control valve, place the valve in the proper position to direct hydraulic oil flow to the guide wheel equipment.
4. Do not release the guide wheel unit locking mechanism. Push the control valve handle (2) towards the control valve to bottom out the hydraulic cylinder against the locking mechanism. Hold the control valve handle in this position while reading the hydraulic pressure on the gauge.
5. While holding the control valve handle, turn the adjusting screw clockwise to increase the pressure. Stop when the pressure gauge remains steady at a constant pressure. This steady pressure is the relief setting of the flow divider valve.

If the hydraulic pressure indicated is 2500 PSI (172 bar) and remained steady, the flow divider valve relief pressure is set correctly.

If the hydraulic pressure indicated is not 2500 PSI (172 bar), the flow divider valve relief pressure will have to be adjusted. See Adjusting Flow Divider Valve Relief Pressure.

6. While holding the control valve handle, turn the adjusting screw of the control valve counter-clockwise to decrease the pressure. Stop when the pressure gauge remains steady at a constant pressure of 2200 PSI (152 bar). Release the control valve handle.
7. Disengage the mechanical PTO hydraulic pump or stop the auxiliary hydraulic power source. Remove the pressure gauge from the test port (1). Install the relief valve cap (3).

Adjusting Flow Divider Valve Relief Pressure



- **DEPRESSURIZE HYDRAULIC SYSTEM BEFORE ATTEMPTING TO ADJUST THE FLOW DIVIDER VALVE. COMPONENTS AND OIL UNDER PRESSURE COULD CAUSE SEVERE BODILY INJURY.**

Adjustments

FLOW DIVIDER VALVE HYDRAULIC PRESSURE

Adjusting Flow Divider Valve Relief Pressure - See Chart 3-15 and Figure 3-16

8. Disengage the mechanical PTO hydraulic pump or stop the auxiliary hydraulic power source. Stop the vehicle engine. Depressurize the vehicle hydraulic system.
9. Disassemble the flow divider valve by removing the relief cap (1), o-ring (2), relief spring (3), shims (4) and spring guide (5). The relief ball (6), relief seat (7), back-up washer (8) and o-ring (9) in the flow divider valve do not have to be removed.
10. Add or remove different thicknesses of shims (4) between the relief spring (3) and relief guide (5) to obtain the correct pressure setting of 2500 PSI (172 bar). See Chart 3-15 for approximate pressure change in relationship to shim thickness. Re-assemble the flow divider valve in reverse order.

CHART 3-15
SHIM / PRESSURE CHART

SHIM THICKNESS	APPROXIMATE PRESSURE CHANGE
.010 in.	75 PSI
.021 in.	175 PSI
.042 in.	425 PSI

11. Repeat Steps 3 - 10 until the correct flow divider valve relief pressure setting is obtained.
12. If the flow divider valve relief pressure can not be adjusted to 2500 PSI (172.4 bar), the problem may be with the hydraulic pump.

FIGURE 3-16
FLOW DIVIDER VALVE

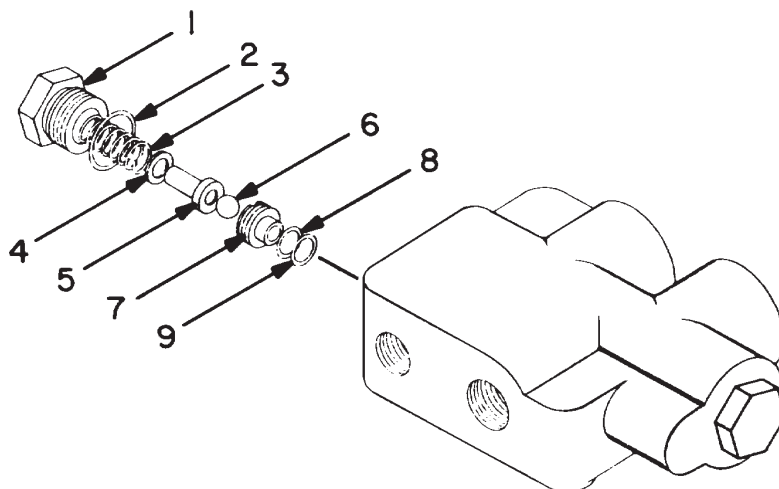

**SECTION 4 - MAINTENANCE
TABLE OF CONTENTS**

Maintenance Schedule

MAINTENANCE SCHEDULE..... 4 - 2

Waste Disposal

WASTE DISPOSAL 4 - 3

Guide Wheel Equipment Lubrication

FRONT GUIDE WHEEL UNIT LUBRICATION 4 - 4
REAR GUIDE WHEEL UNIT LUBRICATION..... 4 - 5
RE-PACKING GUIDE WHEEL BEARINGS..... 4 - 6

Guide Wheels

ALLOWABLE WEAR 4 - 8
FLANGE AND TREAD RUN OUT 4 - 9

Hoses And Fittings

INSPECTION, MAINTENANCE, REPLACEMENT AND INSTALLATION..... 4 - 10
HOSE BAND 4 - 10

Vehicle Wheels

WHEEL REPLACEMENT..... 4 - 11
TIRE REPLACEMENT 4 - 11

Bolt Torque Requirements

BOLT TORQUE REQUIREMENTS 4 - 11

Brake Shoe Replacement And Adjustment

DISASSEMBLY 4 - 12
CLEANING AND INSPECTION 4 - 14
ASSEMBLY 4 - 14
ADJUSTMENT 4 - 16

Maintenance Schedule



■ **APPLY THE VEHICLE PARKING BRAKE AND STOP THE ENGINE WHEN PERFORMING MAINTENANCE, MAKING ADJUSTMENTS, WORKING UNDER VEHICLE OR GUIDE WHEEL EQUIPMENT OR WHENEVER UNINTENDED MOVEMENT OF THE VEHICLE COULD OCCUR.**

■ **RE-TORQUE VEHICLE WHEEL LUG NUTS AND GUIDE WHEEL LUG NUTS AFTER THE FIRST 50 MILES OF OPERATION. THEREAFTER TORQUE WHEEL LUG NUTS ACCORDING TO VEHICLE MANUFACTURER'S WHEEL TORQUE SPECIFICATIONS.**

FAILURE TO HEED THESE WARNINGS COULD RESULT IN SEVERE BODILY INJURY.

DAILY:

4

1. Inspect the front and rear guide wheel units for damaged, worn or missing parts.
2. Check the mechanical locks and lock pins for ease of operation.
3. Check the hydraulic reservoir to ensure that the oil level is full. If low, fill to the proper level with the correct fluid.
4. When the vehicle is operated on the track, listen for unusual noises. Unusual noises may indicate incorrectly lowered guide wheels, damaged or missing parts, or insufficient lubrication. Pay attention to the quality of the ride. Check the guide wheel equipment alignment if the vehicle crowds one side of the track instead of floating from side to side. See Adjustments - Guide Wheel Equipment Alignment Procedure.

WEEKLY:

1. Check the guide wheel equipment alignment. See Adjustment Section, Guide Wheel Equipment Alignment Procedure - Vehicle Track Test.
2. Inspect the guide wheel tread and flanges for wear or damage. See Maintenance - Guide Wheel Allowable Wear.
3. Spin each guide wheel by hand, checking for ease of rotation. If the guide wheel does not rotate easily, the guide wheel bearings may be lacking lubrication or may be damaged. Inspect, re-pack or replace the bearings if necessary.
4. Inspect the vehicle wheels, studs, lug nuts and tires for wear, damage, cuts etc.

Maintenance Schedule

WEEKLY:

5. Check the vehicle tires for correct inflation pressure. Operate at the tire manufacturer's recommended maximum pressure printed on the sidewalls of the tires, or the wheel manufacturer's recommended maximum pressure stamped on the wheel, whichever is lower.
6. Check all bolts for tightness. See Appendices - Appendix A, Bolt Torque Requirement Chart.

At 50 Vehicle Miles (80 Vehicle km):

Torque the vehicle wheel lug nuts and guide wheel lug nuts to the recommended specifications. Thereafter refer to the vehicle manufacturer's wheel torque specifications.

Every 2,000 Track Miles (3200 km):

Lubricate the guide wheel unit locations provided with grease fittings. See Guide Wheel Equipment Lubrication.

At 10,000 Track Miles (16000 km):

Re-pack and adjust the guide wheel bearings. See Re-packing Guide Wheel Bearings.

Waste Disposal

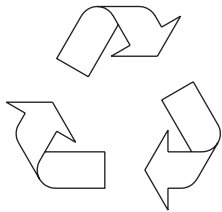

Dispose of waste properly. Improper disposal of waste can threaten the environment. The operation and maintenance of Harsco Track Technologies equipment may involve the use of such items as hydraulic oil, engine oil, fuel, coolant, brake fluid, filters, batteries, etc.

Use leak proof containers when draining fluids. Do not pour waste onto the ground, down a drain, or into any water source. Inquire on the proper way to recycle or dispose of waste according to applicable Federal, State and/or local regulations.

Guide Wheel Equipment Lubrication

Lubricate the guide wheel equipment every 2000 track miles (maximum) or each time the vehicle is serviced.

FRONT GUIDE WHEEL UNIT LUBRICATION - See Figure 4-1

1. Apply the parking brake. Stop the engine. Turn the ignition switch off.
2. Lubricate grease fittings (A) using Mobil Special Moly, or equivalent.
3. Re-pack the guide wheel bearings (B) every 10,000 track miles (maximum) or at least once every two years (minimum), whichever occurs first. See Re-packing Guide Wheel Bearings.

FIGURE 4-1
FRONT GUIDE WHEEL UNIT LUBRICATION

4

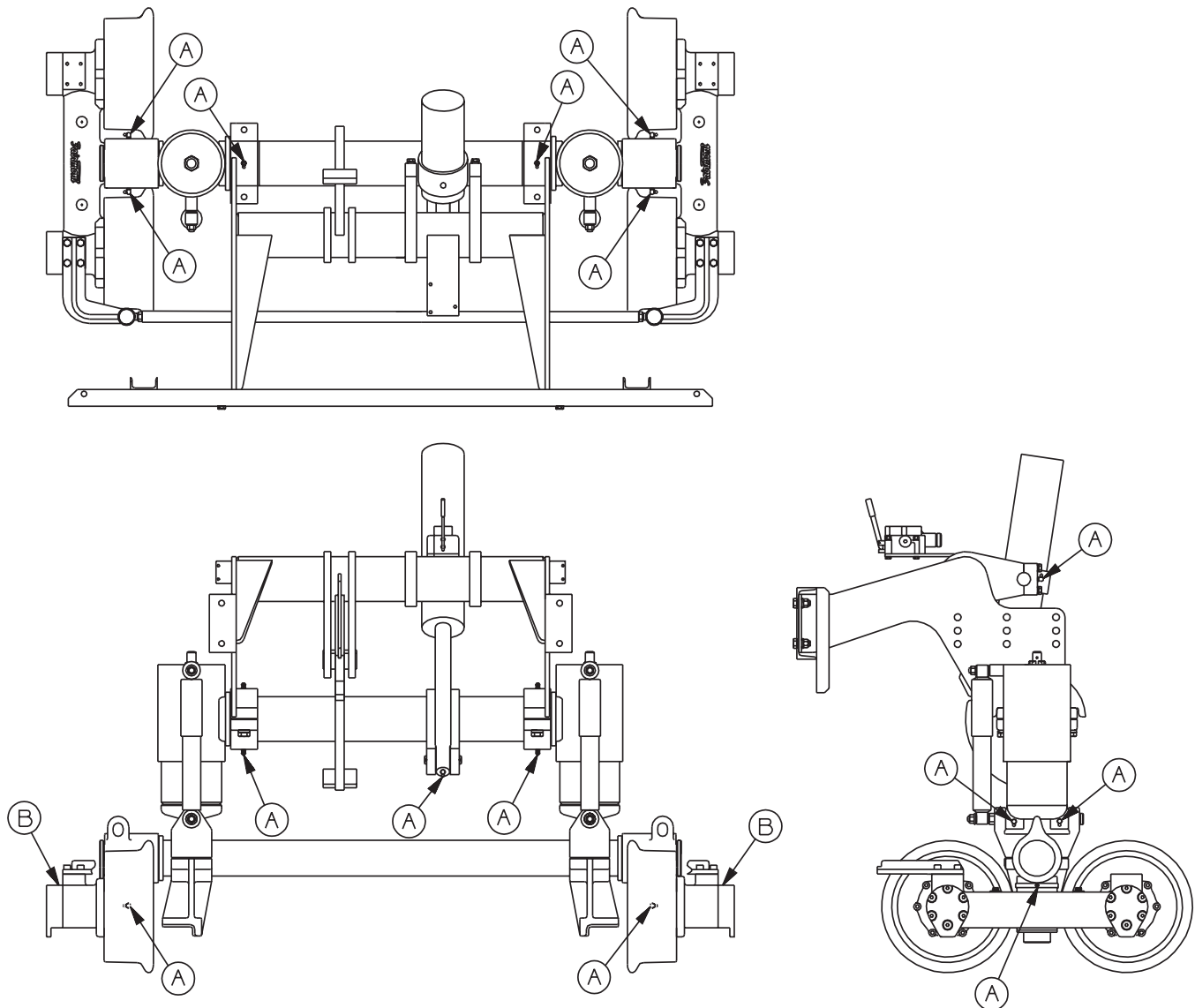

Guide Wheel Equipment Lubrication

REAR GUIDE WHEEL UNIT LUBRICATION - See Figure 4-2

1. Apply the parking brake. Stop the engine. Turn the ignition switch off.
2. Lubricate grease fittings (A) using Mobil Special Moly, or equivalent.
3. Re-pack the guide wheel bearings (B) every 10,000 track miles (maximum) or at least once every two years (minimum), whichever occurs first. See Re-packing Guide Wheel Bearings.

FIGURE 4-2
REAR GUIDE WHEEL UNIT LUBRICATION

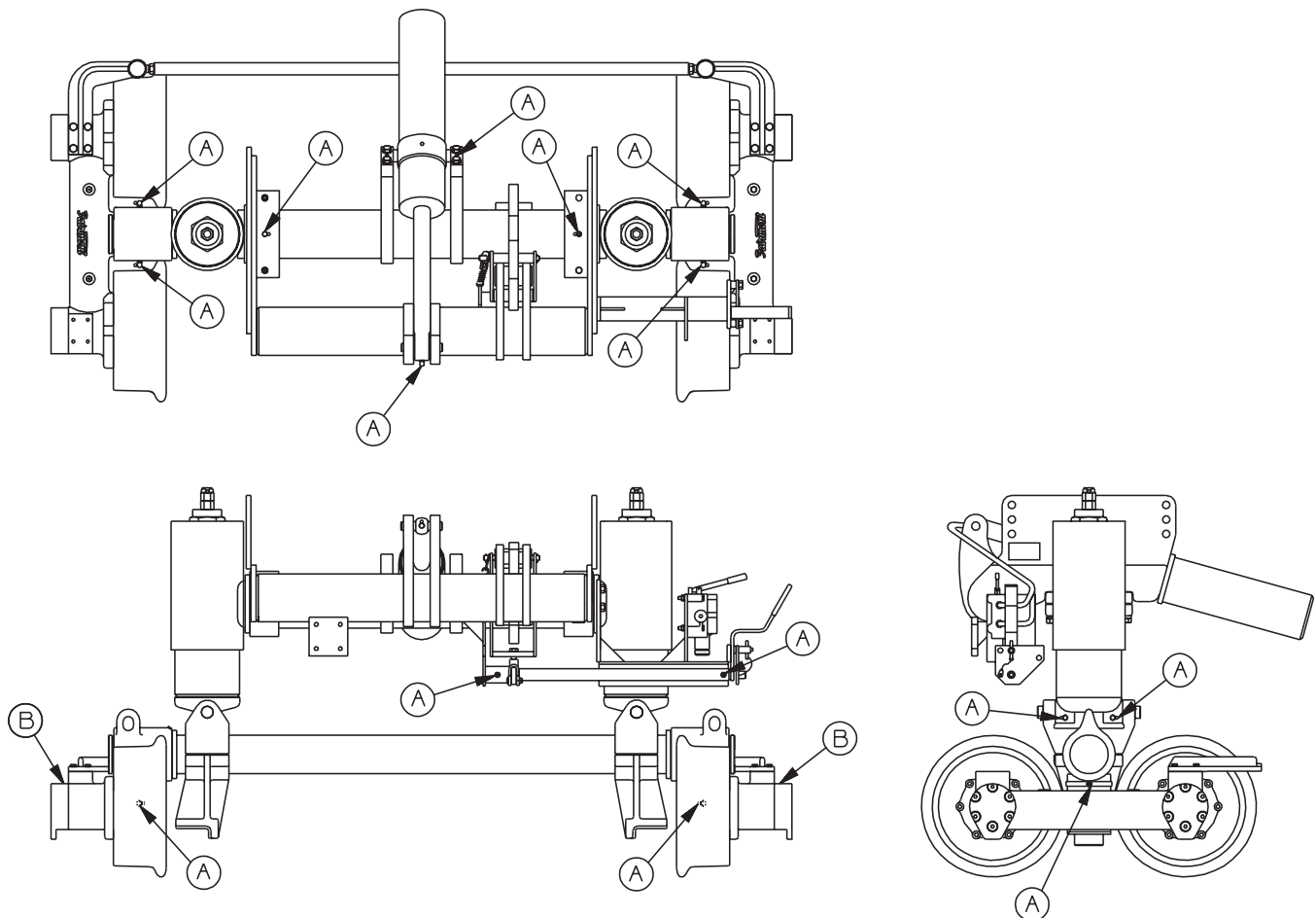

Guide Wheel Equipment Lubrication

RE-PACKING GUIDE WHEEL BEARINGS - See Figure 4-3

Re-pack the guide wheel bearings every 10,000 track miles (maximum) or at least once every two years (minimum), whichever occurs first.

1. Apply the parking brake. Raise and lock the front and rear guide wheel units in the "highway" position. Stop the vehicle engine. Shut off the ignition switch.
2. Remove the six 5/16 x 2 inch hex head cap screws (1) and 5/16 inch lock washers (2). Remove the hub cap (3) and gasket (4) from wheel arm (5).
3. Remove the 3/8 x 2-1/2 inch cotter pin (6), 1-1/2 inch castle nut (7) and spindle washer (8).
4. Pull the guide wheel (10) and spindle (11) from the wheel arm (5). Remove the outer bearing cone (9) and grease seal (13) from the wheel arm (5). Remove the inner bearing cone (12) from spindle (11).
5. Clean all components of old grease and dirt.
6. Inspect the spindle, bearing cones and cups for nicks, gouges and wear. If any of these are evident, replace the component.
7. Measure the guide wheel wear. See Maintenance - Guide Wheels, Allowable Wear.
8. Coat the spindle surface, grease seal surface, both bearing cup surfaces, pack both bearing cones and fill the wheel arm cavity 1/2 full (50 %) using Mobil HP grease, or equivalent.
9. Install the inner bearing cone (12) on spindle (11). Install a new grease seal (13) into the wheel arm.
10. Slide the guide wheel (10) and spindle (11) into the wheel arm (5). Install the outer bearing cone (9), spindle washer (8) and 1-1/2 inch castle nut (7) onto spindle (11).
11. Torque the castle nut (7) to approximately 20 ft lbs. Then loosen the castle nut. This is especially important if new bearing cups have been installed.
12. Torque the castle nut (7) to 7 ft lbs (zero clearance). Then back the castle nut off 1/2 to 1 flat of the nut (.001 - .010 inch clearance). Secure the castle nut using a new cotter pin (6).
13. Install hub cap (3) and a new gasket (4) onto the wheel arm (5). Secure hub cap (3) with the six 5/16 x 2 inch hex head cap screw (1) and 5/16 inch lock washers (2).

Guide Wheel Equipment Lubrication

RE-PACKING GUIDE WHEEL BEARINGS

FIGURE 4-3
RE-PACKING GUIDE WHEEL BEARINGS

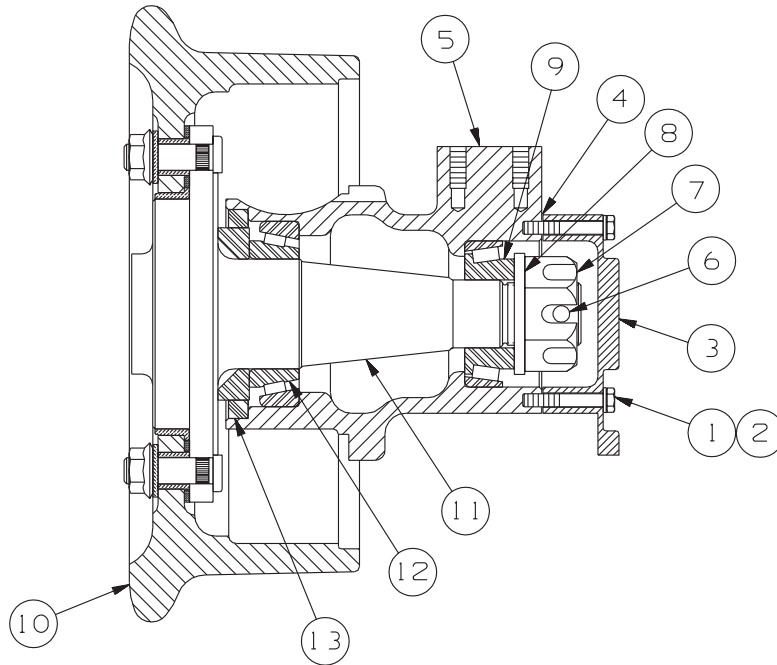

SE140177A-5

Guide Wheels

ALLOWABLE WEAR - See Figure 4-4



■ REPLACE ANY GUIDE WHEEL IMMEDIATELY WHICH SHOWS DAMAGE AND/OR HAS WORN MORE THAN THE ALLOWABLE LIMITS. FAILURE TO COMPLY COULD RESULT IN DERAILMENT OF THE VEHICLE, AND SEVERE BODILY INJURY.

1. Tools needed: Harsco Track Technologies wheel caliper (M019889), or equivalent.
2. Measure the guide wheel flange at Position "A" with the wheel caliper. The minimum allowable flange dimension at Position "A" is 7/8 inch (22.2 mm).

If the guide wheel flange dimension is less than the allowable limit, replace the guide wheel immediately.

4

3. Measure the guide wheel tread at Position "B" with the wheel caliper. The minimum allowable tread dimension at Position "B" is 19/32 inch (15.1 mm).

If the guide wheel tread dimension is less than the allowable limit, replace the guide wheel immediately.

4. The entire guide wheel must not have any gouges or cracks. If any of these are evident, replace the guide wheel immediately.

FIGURE 4-4
ALLOWABLE GUIDE WHEEL WEAR

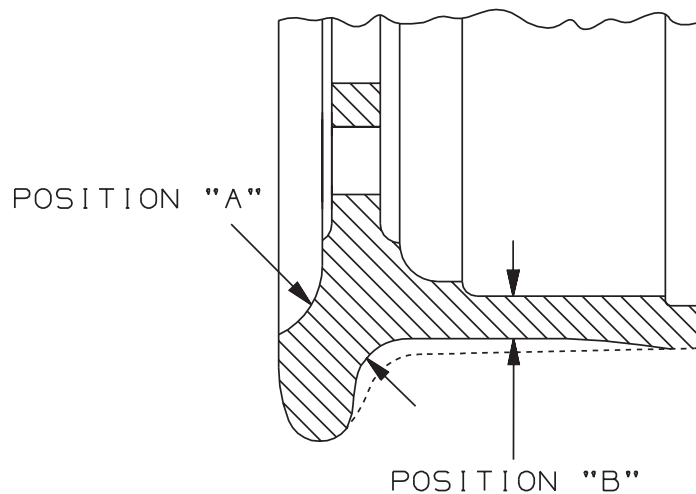

Guide Wheels

FLANGE AND TREAD RUN OUT

Guide wheels which run correctly on the tread and flange will vibrate and can cause a rough ride. Flange and tread run out should be checked whenever the guide wheel is removed from the spindle and re-installed or whenever a new guide wheel is applied to the unit.

Flange Run Out

1. Clamp a dial indicator on the wheel arm so that the plunger on the indicator is against the rail side of the guide wheel flange.
2. Rotate the guide wheel one complete revolution. The indicated flange run out should be less than .030 inch. If the flange run out is less than .030 inch, check the tread run out. If the flange run out is greater than .030 inch:
 - a. Check the guide wheel bearings. Adjust or replace the bearings.
 - b. Remove the guide wheel. Check for foreign material, damaged or missing insulation washers between the hub and the guide wheel. Replace the guide wheel. Torque the guide wheel lug nuts to 75 ft. lbs.
 - c. Remove the guide wheel. Relocate the guide wheel in a different position on the hub. Torque the guide wheel lug nuts to 75 ft. lbs.

Tread Run Out

1. Clamp a dial indicator on the wheel arm so that the plunger on the indicator is against the tread on the guide.
2. Rotate the guide wheel one complete revolution. The indicated tread run out should be less than .010 inch. If the tread run out is less than .010 inch, the guide wheel tread run out is acceptable. If the tread run out is greater than .010 inch:
 - a. Check the guide wheel bearings. Adjust or replace the bearings.
 - b. Remove the guide wheel. Check for foreign material, damaged or missing insulation washers between the hub and the guide wheel. Replace the guide wheel. Torque the guide wheel lug nuts to 75 ft. lbs.
 - c. Remove the guide wheel. Relocate the guide wheel in a different position on the hub. Torque the guide wheel lug nuts to 75 ft. Lbs.
3. If the flange or tread run out is not within the acceptable limits, replace the guide wheel.

Hoses and Fittings



- ALL HOSES AND FITTINGS ON THIS EQUIPMENT MUST COMPLY WITH SAE STANDARD J1273 RECOMMENDED PRACTICE FOR SELECTION, INSTALLATION AND MAINTENANCE OF HOSE AND HOSE ASSEMBLIES. FAILURE TO COMPLY TO THIS STANDARD COULD RESULT IN SEVERE BODILY INJURY.

INSPECTION, MAINTENANCE, REPLACEMENT AND INSTALLATION

The inspection, maintenance, replacement and installation of hydraulic hose assemblies and fittings on this equipment must conform with SAE Standard J1273. See Appendices Section - Appendix B.

HOSE BAND - See Figure 4-5

4

All Harsco Track Technologies original and replacement hose assemblies manufactured for this equipment at the Harsco Track Technologies, Harsco Corporation Fairmont, Minnesota plant facility are supplied with a hose band displaying the date of manufacture and the Harsco Track Technologies part number. See Figure 4-5 for explanation of the hose band. The hose assembly illustrated in the example was manufactured in February 2001 and is Harsco Track Technologies part number 188662.

FIGURE 4-5
HOSE BAND

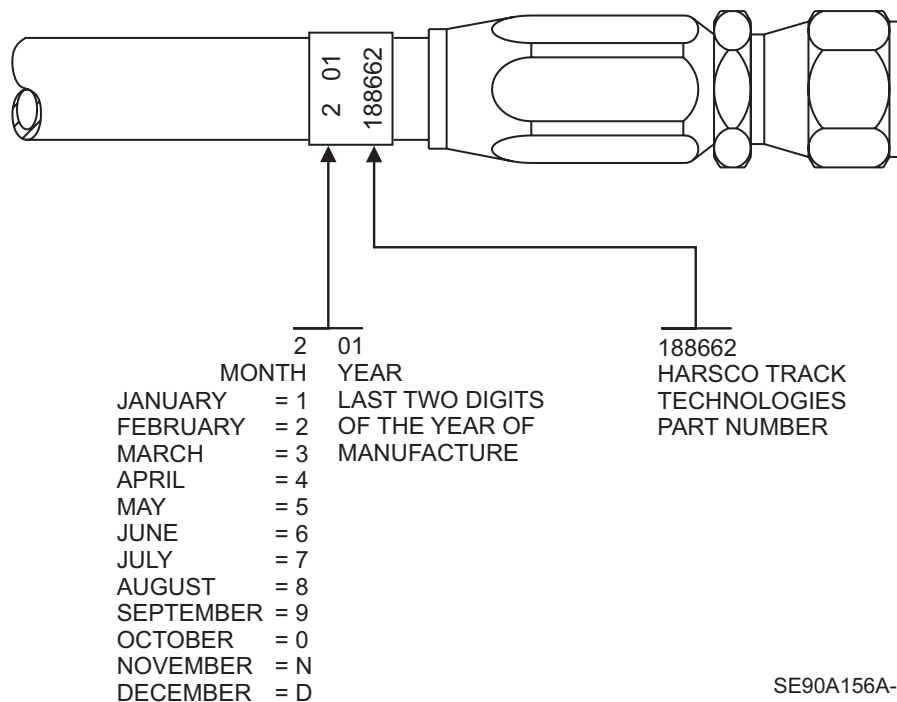

Vehicle Wheels

WHEEL REPLACEMENT



- **USE REPLACEMENT WHEELS AS RECOMMENDED IN THE HARSCO TRACK TECHNOLOGIES HY-RAIL® VEHICLE SPECIFICATIONS MANUAL. FAILURE TO COMPLY COULD RESULT IN BODILY INJURY AND/OR PROPERTY DAMAGE.**

Use replacement wheel rim(s) as recommended in the Harsco Track Technologies HY-RAIL® Vehicle Specifications Manual to ensure correct vehicle wheel spacing and accurate guide wheel load. The wheels and tires should be static balanced or balanced after installation on the vehicle for best results. Torque vehicle wheel lug nuts to recommended specifications.

TIRE REPLACEMENT



- **USE REPLACEMENT TIRES WITH THE SAME ROLLING RADIUS, TREAD WIDTH, PLY RATING, AND LOAD RATING AS RECOMMENDED IN THE HARSCO TRACK TECHNOLOGIES HY-RAIL® VEHICLE SPECIFICATIONS MANUAL. FAILURE TO COMPLY COULD RESULT IN BODILY INJURY AND/OR PROPERTY DAMAGE.**

4

Bias ply tires are the recommended tire for use on vehicles equipped with guide wheel equipment. Radial tires may influence vehicle tracking. Performance of vehicles equipped with radial tires is the responsibility of the end user.

Replacement tires must have the same rolling radius, tread width, ply rating, and load rating as recommended in the Harsco Track Technologies HY-RAIL® Vehicle Specifications Manual. Using tires of equal diameter will help keep the speedometer reading and the guide wheel load accurate. Tires must have a minimum 6-1/2 inches of tread width.

Inflate tires to the tire manufacturer's recommended maximum pressure printed on the sidewall of the tire or to the wheel manufacturer's recommended maximum pressure stamped on the wheel, whichever is lower. The wheels and tires should be static balanced or balanced after installation on the vehicle for best results. Torque vehicle wheel lug nuts to recommended specifications.

Bolt Torque Requirements



- **CHECK ALL BOLTS AND NUTS PERIODICALLY. KEEP BOLTS AND NUTS TIGHTENED TO THE TORQUE SPECIFIED IN APPENDICES SECTION - APPENDIX A. IF BOLT REPLACEMENT BECOMES NECESSARY, REPLACE WORN BOLT WITH EQUAL S.A.E. GRADE NUMBER BOLT. FAILURE TO COMPLY COULD RESULT IN BODILY INJURY, AND/OR PROPERTY DAMAGE.**

See Appendices Section - Appendix A, for bolt torque requirements table and grade identification markings used by manufacturers.

Brake Shoe Replacement And Adjustment

FIGURE 4-6
TYPICAL BRAKE WITH AUTOMATIC ADJUSTER PARTS

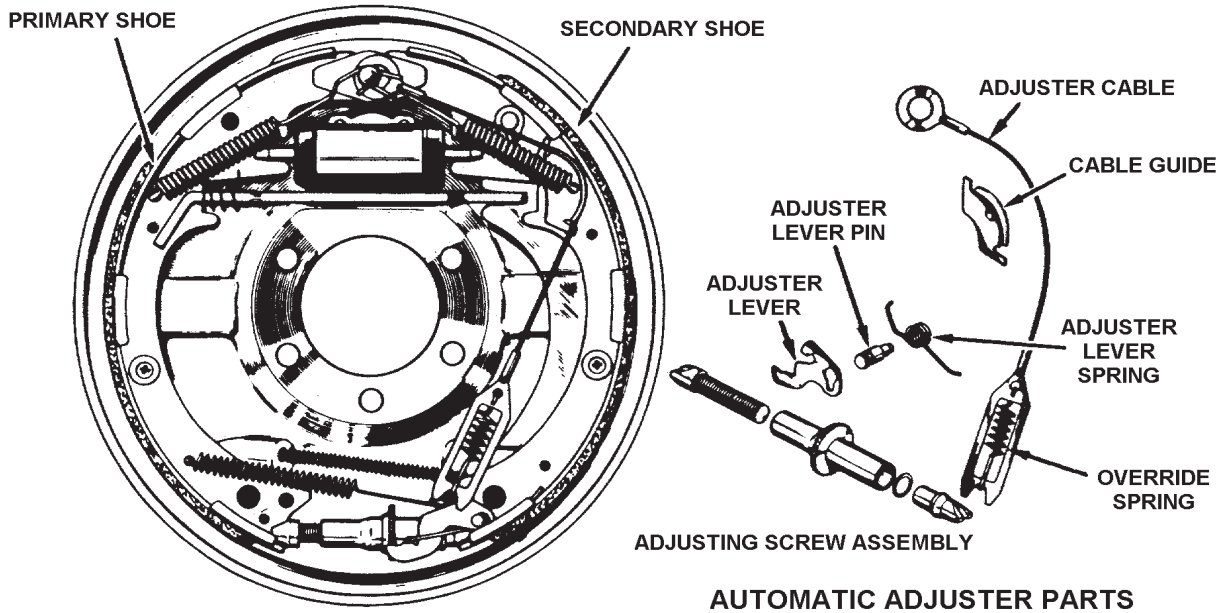

SE86A105A-1

DISASSEMBLY

1. Remove the guide wheel from the spindle. See Figure 4-7. If brake shoes interfere with the wheel removal, hold the adjusting lever away from the star wheel with a screw driver and use a brake adjusting tool to back the brake adjuster off.
2. After removing the guide wheel, note the position and placement of the brake components so they can be reinstalled in the correct positions. Pay special attention to the primary and secondary brake shoe placement.

FIGURE 4-7
STAR WHEEL ADJUSTMENT

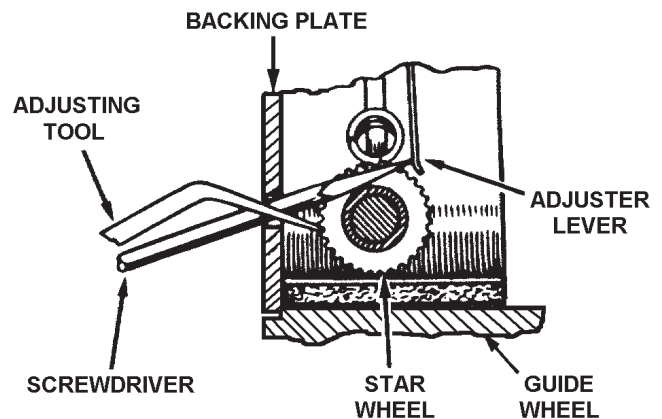

Brake Shoe Replacement And Adjustment

DISASSEMBLY

3. See Figure 4-8. Install a wheel cylinder clamp to hold the brake pistons in place.
4. See Figure 4-9. Using brake spring tools, remove the brake shoe return springs and brake shoe return springs.
5. Remove the automatic adjuster spring, cable, cable guide, adjuster lever, lever pin and lever spring.
6. See Figure 4-10. Remove the brake shoes, adjusting screw assembly and shoe to shoe spring as an assembly. Overlap the anchor end of the shoes to reduce the spring tension. Remove the shoe to shoe spring and adjusting screw assembly.

FIGURE 4-8
WHEEL CYLINDER CLAMP

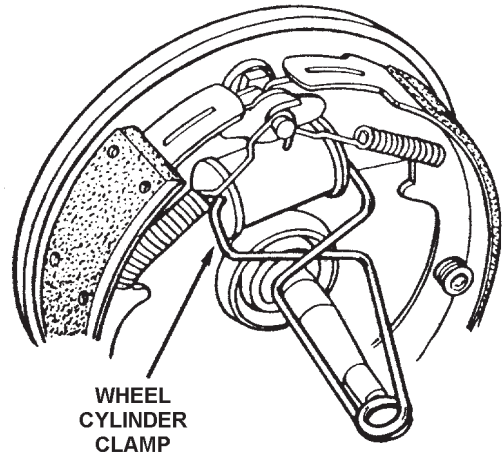

SE86A105A-2

4

FIGURE 4-9
REMOVING SHOE RETURN SPRINGS

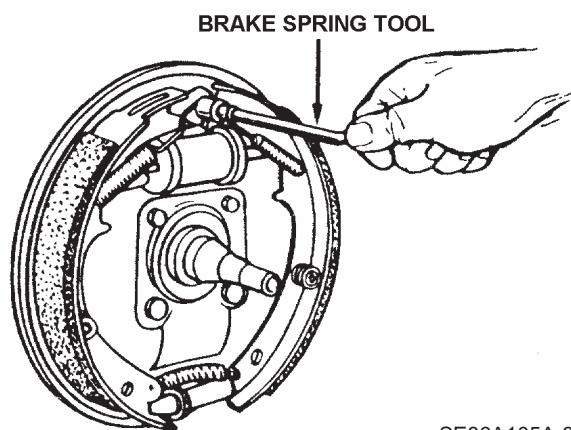

SE86A105A-3

FIGURE 4-10
REMOVING / INSTALLING SHOES

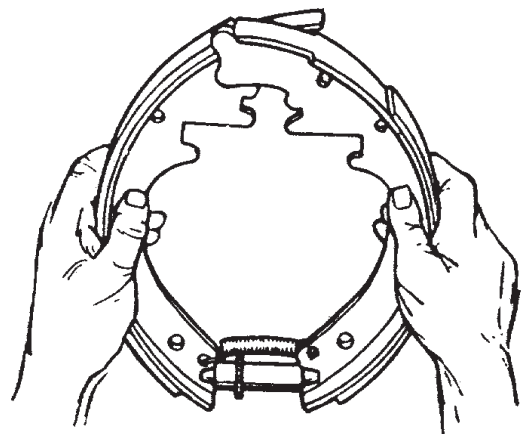

SE86A105A-4

Brake Shoe Replacement And Adjustment

CLEANING AND INSPECTION

1. Clean the backing plate. Be sure that the shoe support points are smooth and free of rough edges.
2. Clean the adjusting screw threads. Check for thread damage. Make sure that the star wheel turns freely on the adjusting screw.
3. Check the springs for loss of tension or damage. Check all other parts for wear or damage. Replace weak springs and any worn or damaged parts.

ASSEMBLY

4

1. Apply a light coat of high temperature lubricant to the shoe support points on the backing plate and to the adjusting screw threads.
2. See Figure 4-11. If the new secondary brake shoes do not have an adjuster lever pin installed, install a new one. Drive or press the new adjuster lever pin in the small hole near the lower end of the secondary brake shoe web. Install the pins on the side of the brake shoe web that is facing outward when the shoes are installed on the unit. Be sure the pin is fully seated.
3. See Figure 4-10. Assemble the brake shoes, adjusting screw assembly and shoe to shoe spring. Make sure the primary and secondary brake shoes are correctly assembled. Place this assembly on the backing plate and secure with the brake shoe retainer springs and clips.

FIGURE 4-12
ADJUSTER PINS IN SHOES

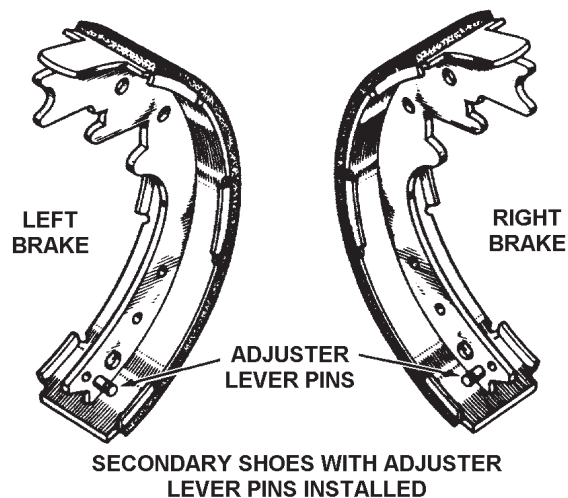

Brake Shoe Replacement And Adjustment

ASSEMBLY

4. Position the brake shoe guide plate and the eye loop end of the adjuster cable on the anchor pin. Install the primary brake shoe return spring.
5. Install the adjuster cable guide on the secondary brake shoe web. Install the secondary brake shoe return spring.
6. Make sure the brake cylinder shoe links properly engage the brake shoe webs. Remove the wheel cylinder clamp.
7. Install the adjuster lever and adjuster lever spring on the adjuster lever pin in the secondary brake shoe. Place the adjuster cable over the cable guide and attach the override spring end to the adjuster lever. Make sure that the override spring is installed with the open end of the hook facing outward. Pull the adjuster cable several times to check the automatic adjuster action.

Brake Shoe Replacement And Adjustment

ADJUSTMENT

1. See Figures 4-13 and 4-14. If a brake shoe gauge is available, set the gauge to the inside diameter of the guide wheel. Position the other side of the brake shoe gauge over the brake shoes. Expand the brake shoes by manually turning the star wheel until the gauge just slides over the brake shoe linings. Rotate the gauge around the lining surface to ensure proper clearance.
2. Install the guide wheel on the spindle. Torque the wheel lug nuts to 75 ft. lbs.
3. If a brake shoe gauge is not available, the preliminary adjustment can be made with an adjuster tool through the access slot in the backing plate.
4. Install the guide wheel on the spindle. Torque the guide wheel lug nuts to 75 ft. lbs.
5. Remove the dust plug from the access slot in the backing plate. Insert the adjusting tool in the access slot. Turn the star wheel until a drag is felt while turning the guide wheel.
6. See Figure 4-7. Hold the adjusting lever away from the star wheel with a screw driver and use the brake adjusting tool to back the brake adjuster off until the guide wheel turns freely. Replace the dust plug in the access slot.
7. To make final adjustments to the brake shoes, place the vehicle on track. See Operation - Placing Vehicle On Track. Operate the vehicle slowly with a number of alternating forward and reverse stops. These stops will activate the automatic adjusters and position the brake shoes properly.

FIGURE 4-13
CHECKING BRAKE GAUGE

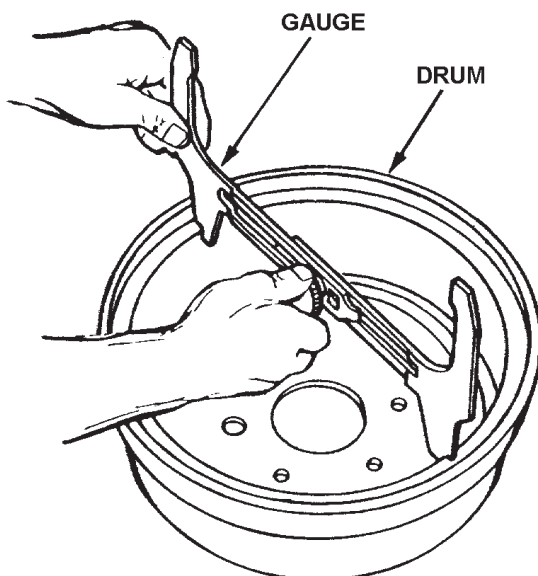

SE86A105A-7

FIGURE 4-14
PRELIMINARY SHOE ADJUSTMENT

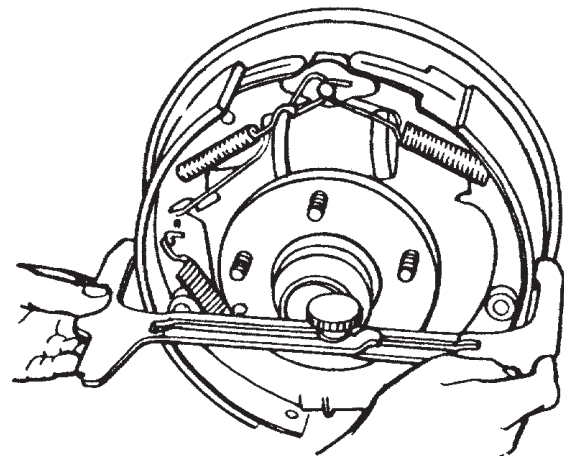

SE86A105A-8

**SECTION 5 - TROUBLESHOOTING
TABLE OF CONTENTS**

Troubleshooting Guide Wheel Equipment

TROUBLESHOOTING CHART 5 - 2

Troubleshooting Guide Wheel Equipment

5

PROBLEM	PROBABLE CAUSE	POSSIBLE REMEDY
Hydraulic pump not delivering oil.	<p>Mechanical PTO not engaged or control valve not shifted to direct oil flow to guide wheel equipment.</p> <p>Hydraulic reservoir oil level low.</p> <p>Oil restricted to pump intake.</p> <p>Components bent, broken, worn, etc.</p>	<p>Engage mechanical PTO. Shift control valve to direct oil flow to guide wheel equipment.</p> <p>Fill reservoir to full level with recommended hydraulic oil.</p> <p>Check all strainers and filters for dirt and sludge. Clean and replace if necessary.</p> <p>Replace components.</p>
Guide wheel units do not lower or raise.	<p>Locks engaged.</p> <p>Hydraulic pump not operating.</p> <p>Hydraulic reservoir oil level low.</p> <p>Components bent, broken, worn, etc.</p>	<p>Disengage Locks. See Operation Section - Placing Vehicle On Track or Removing Vehicle From Track.</p> <p>Start hydraulic pump.</p> <p>Fill reservoir to full level with recommended hydraulic oil.</p> <p>Replace components.</p>
Guide wheel units are difficult to lower or raise.	<p>Vehicle over-loaded.</p> <p>Guide wheel load adjusted incorrectly.</p> <p>Control valve relief pressure set incorrectly.</p> <p>Components bent, broken, worn, etc.</p>	<p>Remove excess load from vehicle.</p> <p>Check guide wheel load. See Adjustments - Guide Wheel Load.</p> <p>Check control valve relief pressure. See Adjustments - Hydraulic Pressure Adjustments.</p> <p>Replace components.</p>

Troubleshooting Guide Wheel Equipment

PROBLEM	PROBABLE CAUSE	POSSIBLE REMEDY
<p>Lock pins cannot be inserted when guide wheel unit is in "rail" or "highway" position.</p>	<p>Foreign material in locking mechanism.</p> <p>Locking mechanism adjusted incorrectly.</p> <p>Components bent, broken, worn, etc.</p>	<p>Clean foreign material from mock mechanism.</p> <p>See Adjustments - Guide Wheel Unit Lock Adjustment.</p> <p>Replace components.</p>
<p>Vehicle front tires clear rail less than 1-1/2" (38 mm) when vehicle is on track and loaded.</p>	<p>Vehicle overloaded.</p> <p>Axle Hooks not lifting front axle high enough.</p> <p>Front guide wheel unit not positioned in proper holes of mounting brackets.</p>	<p>Redistribute or remove some of the load.</p> <p>See Adjustments - Vehicle Front Tire Clearance - Rail Position.</p> <p>Mount front guide wheel unit in correct mounting holes. See application drawings supplied with guide wheel equipment group.</p>
<p>Vehicle derails.</p>	<p>Guide wheel units, vehicle rear axle, etc. not aligned with vehicle frame.</p>	<p>Check alignment. See Adjustments - Guide Wheel Equipment Alignment Procedure.</p>
<p>Vehicle pulls noticeably to the left or right when on track.</p>	<p>Vehicle loaded heavy on one side.</p> <p>Guide wheel units, vehicle rear axle, etc. not aligned with vehicle frame.</p> <p>Incorrect or worn vehicle rear tire.</p>	<p>Move load to center of vehicle.</p> <p>Check alignment. See Adjustments - Guide Wheel Equipment Alignment Procedure.</p> <p>Check for correct rear tire. Replace if necessary. Replace worn rear tire.</p>

Troubleshooting Guide Wheel Equipment

PROBLEM	PROBABLE CAUSE	POSSIBLE REMEDY
Vehicle pulls noticeably to the left or right when on track. - Continued	Vehicle rear tires under inflated. Guide wheel brake shoes dragging.	Check pressure. Inflate if low. Do not exceed tire manufacturer's recommended maximum pressure printed on the sidewalls, or wheel manufacturer's recommended maximum pressure stamped on the wheel, whichever is lower. Re-adjust brake shoes. See Adjustments - Brake Shoe Replacement and Adjustment.
Vibration felt in the vehicle when traveling on track.	Guide wheel units mounting fasteners loose. Guide wheel bearings worn. Guide wheels worn. Guide wheels have excessive run out. Guide wheel swivel bearings worn. Vehicle rear rim bent. Vehicle rear tires out of balance.	Tighten all bolts to recommended torque. Replace bearings, wheel or axle. Check guide wheel wear. See Maintenance - Guide Wheels, Allowable Wear. Check guide wheel flange and tread run out. See Maintenance - Guide Wheel Flange and Tread Run Out. Check. Repair or replace. Replace. See - Vehicle Applications. Balance tires.

5

Troubleshooting Guide Wheel Equipment

PROBLEM	PROBABLE CAUSE	POSSIBLE REMEDY
<p>Vehicle load on spring cells exceeds guide wheel unit maximum rated load.</p>	<p>Vehicle overloaded.</p> <p>Vehicle rear tires under inflated.</p> <p>Rear guide wheel unit not adjusted to carry approximately 50% of vehicle rear axle curb weight or 5,300 lbs (2,404 kg) minimum.</p>	<p>Redistribute or remove some of the load.</p> <p>Check pressure. Inflate if low. Do not exceed tire manufacturer's recommended maximum pressure printed on the sidewalls, or wheel manufacturer's recommended maximum pressure stamped on the wheel, whichever is lower.</p> <p>Check and adjust. See Adjustments - Guide Wheel Load.</p>
<p>Vibration felt in the vehicle when traveling on highway.</p>	<p>Guide wheel units mounting fasteners loose.</p> <p>Guide wheels are not locked in "highway" position.</p> <p>Vehicle rim bent.</p> <p>Vehicle tires out of balance.</p>	<p>Tighten all bolts to recommended torque.</p> <p>STOP IMMEDIATELY. Make sure both guide wheel units are locked in "highway" position.</p> <p>Replace. See - Vehicle Applications.</p> <p>Balance tires.</p>

SECTION 6 - APPENDICES
TABLE OF CONTENTS

Appendix A - Conversion Tables

BOLT TORQUE REQUIREMENTS - STANDARD TYPE FASTENERS 6 - 2
BOLT TORQUE REQUIREMENTS - SERRATED TYPE FLANGE FASTENERS . . . 6 - 3
BOLT TORQUE REQUIREMENTS - METRIC TYPE FASTENERS 6 - 4
INCH TO MILLIMETERS 6 - 6
FEET TO METERS 6 - 6
POUNDS TO KILOGRAMS 6 - 7
POUNDS PER SQUARE INCH TO BAR 6 - 7
POUNDS PER SQUARE INCH TO KILOPASCALS 6 - 7
FAHRENHEIT TO CELSIUS (Centigrade). 6 - 8
MILES PER HOUR TO KILOMETERS PER HOUR 6 - 9
GALLONS TO LITERS. 6 - 9

Appendix B - SAE J1273

SAE J1273 - NOVEMBER 1991
SELECTION, INSTALLATION AND MAINTENANCE
OF HOSE AND HOSE ASSEMBLIES 6 - 10

Appendix A

**FIGURE 6-1
STANDARD BOLT TORQUE REQUIREMENTS TABLE
STANDARD TYPE FASTENERS**

The torque values listed below are for standard-type fasteners only. The torque values listed are based on wet (lubricated) and dry conditions. The torque values for 1/4 and 5/16 inch size fasteners are listed in in-lbs torque only. The torque values for all other size fasteners are listed in ft-lbs torque with metric equivalents in parentheses. Use lower grade torque values if bolt and nut have different SAE grades. Manufacturer's SAE grade markings may vary.

STANDARD MARKINGS AND TORQUE SPECIFICATIONS

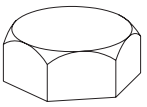
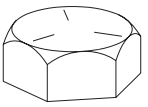
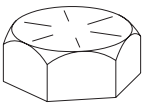
SAE Grade	1 or 2				5				8			
Fastener Standard SAE Grade Markings												
Fastener Body Size Inch Thrd	Wet Torque in-lb		Dry Torque in-lb		Wet Torque in-lb		Dry Torque in-lb		Wet Torque in-lb		Dry Torque in-lb	
1/4 - 20	49		65		75		100		107		142	
1/4 - 28	56		74		86		114		122		162	
5/16 - 18	103		137		157		208		220		293	
5/16 - 24	113		150		173		230		244		325	
Fastener Body Size Inch Thrd	Wet Torque ft-lb (kg-m)		Dry Torque ft-lb (kg-m)		Wet Torque ft-lb (kg-m)		Dry Torque ft-lb (kg-m)		Wet Torque ft-lb (kg-m)		Dry Torque ft-lb (kg-m)	
3/8 - 16	15	(2.1)	20	(2.8)	23	(3.2)	31	(4.2)	32	(4.4)	43	(5.9)
3/8 - 24	17	(2.4)	23	(3.1)	26	(3.6)	35	(4.8)	37	(5.1)	49	(6.8)
7/16 - 14	24	(3.3)	32	(4.4)	37	(5.1)	49	(6.8)	52	(7.2)	69	(9.6)
7/16 - 20	27	(3.7)	36	(5.0)	42	(5.8)	56	(7.7)	58	(8.0)	77	(10.7)
1/2 - 13	39	(5.4)	52	(7.2)	57	(7.9)	76	(10.5)	80	(11.0)	106	(14.7)
1/2 - 20	41	(5.7)	55	(7.5)	64	(8.9)	85	(11.8)	90	(12.4)	120	(16.5)
9/16 - 12	53	(7.3)	71	(9.7)	82	(11.3)	109	(15.1)	115	(15.9)	153	(21.1)
9/16 - 18	59	(8.2)	78	(10.8)	91	(12.6)	121	(16.7)	129	(17.8)	172	(23.7)
5/8 - 11	73	(10.0)	97	(13.4)	113	(15.6)	150	(20.8)	160	(22.1)	213	(29.4)
5/8 - 18	83	(11.5)	110	(15.2)	128	(17.7)	170	(23.5)	180	(24.9)	239	(33.1)
3/4 - 10	129	(17.8)	172	(23.7)	200	(27.7)	266	(36.8)	282	(39.0)	375	(51.8)
3/4 - 16	144	(19.9)	192	(26.5)	223	(30.8)	297	(41.0)	315	(43.6)	419	(57.9)
7/8 - 9	124	(17.1)	165	(22.8)	323	(44.7)	430	(59.4)	454	(62.8)	604	(83.5)
7/8 - 14	138	(19.1)	184	(25.4)	355	(49.1)	472	(65.3)	501	(69.3)	666	(92.1)
1 - 8	188	(26.0)	250	(34.6)	483	(66.8)	642	(88.9)	681	(94.2)	906	(125.2)
1 - 14	210	(29.0)	279	(38.6)	541	(74.8)	720	(99.5)	764	(106.0)	1,016	(140.5)
1-1/8 - 7	266	(36.8)	354	(48.9)	596	(82.4)	793	(109.6)	966	(134.0)	1,285	(177.6)
1-1/8 - 12	297	(41.1)	395	(54.6)	668	(92.4)	888	(122.8)	1,083	(150.0)	1,440	(199.1)
1-1/4 - 7	375	(51.9)	499	(69.0)	841	(116.0)	1,119	(154.6)	1,363	(189.0)	1,813	(250.6)
1-1/4 - 12	415	(57.4)	552	(76.3)	930	(129.0)	1,237	(171.0)	1,509	(209.0)	2,007	(277.5)
1-3/8 - 6	492	(68.0)	654	(90.5)	1,102	(152.0)	1,466	(202.6)	1,787	(247.0)	2,377	(328.6)
1-3/8 - 12	560	(77.4)	745	(103.0)	1,255	(174.0)	1,670	(230.8)	2,034	(281.0)	2,705	(374.0)
1-1/2 - 6	653	(90.3)	868	(120.1)	1,463	(202.0)	1,946	(269.0)	2,371	(328.0)	3,153	(436.0)
1-1/2 - 12	734	(102.0)	976	(135.0)	1,645	(228.0)	2,188	(302.5)	2,668	(369.0)	3,548	(490.6)

Appendix A

**FIGURE 6-2
STANDARD BOLT TORQUE REQUIREMENTS TABLE
SERRATED TYPE FLANGE FASTENERS**

The torque values listed below are for serrated-type flange fasteners only. The torque values listed are based on wet (lubricated) and dry conditions. The torque values for all size fasteners are listed in ft-lbs torque with metric equivalents in parentheses. Use lower grade torque values if bolt and nut have different SAE grades. Manufacturer's SAE grade markings may vary.

STANDARD MARKINGS AND TORQUE SPECIFICATIONS

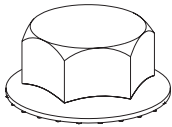
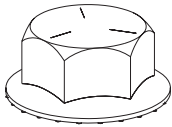
SAE Grade	1 or 2				5			
Fastener Standard SAE Grade Markings								
Fastener Body Size Inch Thrd	Torque				Torque			
	Wet ft-lb	(kg-m)	Dry ft-lb	(kg-m)	Wet ft-lb	(kg-m)	Dry ft-lb	(kg-m)
1/4 - 20	8	(1.1)	11	(1.5)	11	(1.5)	15	(2.1)
1/4 - 28	9	(1.2)	12	(1.7)	12	(1.7)	16	(2.2)
5/16 - 18	13	(1.8)	17	(2.4)	20	(2.8)	27	(3.7)
5/16 - 24	13	(1.8)	17	(2.4)	32	(4.4)	43	(5.9)
3/8 - 16	23	(3.2)	31	(4.3)	40	(5.5)	53	(7.3)
3/8 - 24	25	(3.5)	33	(4.6)	43	(5.9)	57	(7.9)
7/16 - 14	38	(5.3)	51	(7.1)	55	(7.6)	73	(10.1)
7/16 - 20	40	(5.5)	53	(7.5)	60	(8.3)	80	(11.1)
1/2 - 13	60	(8.3)	80	(11.1)	95	(13.1)	127	(17.6)
1/2 - 20	65	(9.0)	87	(12.0)	100	(13.8)	133	(18.4)
9/16 - 12	78	(10.8)	104	(14.4)	140	(19.4)	187	(25.9)
9/16 - 18	85	(11.8)	113	(15.6)	150	(20.7)	200	(27.7)
5/8 - 11	125	(17.3)	167	(23.1)	190	(26.3)	253	(35.0)
5/8 - 18	135	(18.7)	180	(24.9)	220	(30.4)	293	(40.5)
3/4 - 10	225	(31.1)	300	(41.2)	350	(48.4)	467	(64.6)
3/4 - 16	250	(34.6)	333	(46.1)	400	(55.3)	533	(73.7)
7/8 - 9	350	(48.4)	467	(64.6)	550	(76.1)	733	(101.4)
7/8 - 14	375	(51.9)	500	(69.2)	600	(83.0)	800	(110.6)
1 - 8	480	(66.4)	640	(88.5)	750	(103.7)	1,000	(138.3)
1 - 14	500	(69.2)	666	(92.1)	800	(110.6)	1,066	(147.4)

Appendix A

**FIGURE 6-3
BOLT TORQUE REQUIREMENTS TABLE
METRIC TYPE FASTENERS**

Do not use these values if a different torque value or tightening procedure is given for a specific application. Torque values listed are for general use only. Check tightness of fasteners periodically. Fasteners should be replaced with the same or higher property class. If higher property class fasteners are used, these should only be tightened to the strength of the original. Make sure fastener's threads are clean and that thread engagement is properly started. This will help prevent them from failing when tightening.

* Lubricated means coated with a lubricant such as engine oil, or fasteners with phosphate and oil coatings. Dry means plain or zinc plated without any lubrication.

Property Class and Head Markings	<p>4.8</p>				<p>8.8 9.8</p>			
Property Class and Head Markings	<p>5</p>				<p>10</p>			
Size	Class 4.8				Class 8.8 or 9.8			
	* Lubricated		* Dry		* Lubricated		* Dry	
	N - m	lb - ft	N - m	lb - ft	N - m	lb - ft	N - m	lb - ft
M 6	4.8	3.5	6	4.5	9	6.5	11	8.5
M 8	12	8.5	15	11	22	16	28	20
M10	23	17	29	21	43	32	55	40
M12	40	29	50	37	75	55	95	70
M14	63	47	80	60	120	88	150	110
M16	100	73	125	92	190	140	240	175
M18	135	100	175	125	260	195	330	250
M20	190	140	240	180	375	275	475	350
M22	260	190	330	250	510	375	650	475
M24	330	250	425	310	650	475	825	600
M27	490	360	625	450	950	700	1200	875
M30	675	490	850	625	1300	950	1650	1200
M33	900	675	1150	850	1750	1300	2200	1650
M36	1150	850	1450	1075	2250	1650	2850	2100

Appendix A

FIGURE 6-4
BOLT TORQUE REQUIREMENTS TABLE
METRIC TYPE FASTENERS

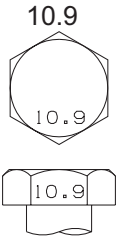
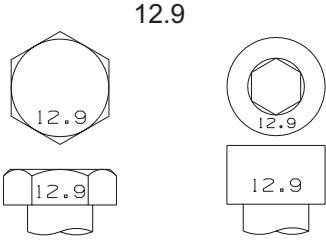
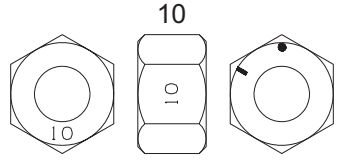
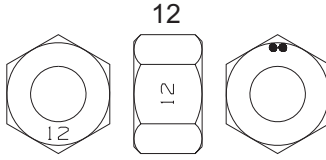
Property Class and Head Markings								
Property Class and Head Markings								
Size	Class 10.9				Class 12.9			
	* Lubricated		* Dry		* Lubricated		* Dry	
	N - m	lb - ft	N - m	lb - ft	N - m	lb - ft	N - m	lb - ft
M 6	13	9.5	17	12	15	11.5	19	14.5
M 8	32	24	40	30	37	28	47	35
M10	63	47	80	60	75	55	95	70
M12	110	80	140	105	130	95	165	120
M14	175	130	225	165	205	150	260	190
M16	275	200	350	255	320	240	400	300
M18	375	275	475	350	440	325	560	410
M20	530	400	675	500	625	460	800	580
M22	725	540	925	675	850	625	1075	800
M24	925	675	1150	850	1075	800	1350	1000
M27	1350	1000	1700	1250	1600	1150	2000	1500
M30	1850	1350	2300	1700	2150	1600	2700	2000
M33	2500	1850	3150	2350	2900	2150	3700	2750
M36	3200	2350	4050	3000	3750	2750	4750	3500

Appendix A

FIGURE 6-5
INCH TO MILLIMETER CONVERSION TABLE
1 INCH = 25.4 MILLIMETERS

FRACTIONS	DECIMALS	MILLIMETERS	FRACTIONS	DECIMALS	MILLIMETERS
	1/64	.016		0.397	
1/32	.031	0.794	17/32	.531	13.494
	3/64	.047		1.191	13.891
1/16	.063	1.588	9/16	.563	14.288
	5/64	.078		1.984	14.684
3/32	.094	2.381	19/32	.594	15.081
	7/64	.109		2.778	15.478
1/8	.125	3.175	5/8	.625	15.875
	9/64	.141		3.572	16.272
5/32	.156	3.969	21/32	.656	16.669
	11/64	.172		4.366	17.066
3/16	.188	4.763	11/16	.688	17.463
	13/64	.203		5.159	17.859
7/32	.219	5.556	23/32	.719	18.256
	15/64	.234		5.953	18.653
1/4	.250	6.350	3/4	.750	19.050
	17/64	.266		6.747	19.447
9/32	.281	7.144	25/32	.781	19.844
	19/64	.297		7.541	20.241
5/16	.313	7.938	13/16	.813	20.638
	21/64	.328		8.334	21.034
11/32	.344	8.731	27/32	.844	21.431
	23/64	.359		9.128	21.828
3/8	.375	9.525	7/8	.875	22.225
	25/64	.391		9.922	22.622
13/32	.406	10.319	29/32	.906	23.019
	27/64	.422		10.716	23.416
7/16	.438	11.113	15/16	.938	23.813
	29/64	.453		11.509	24.209
15/32	.469	11.906	31/32	.969	24.606
	31/64	.484		12.303	25.003
1/2	.500	12.700	1	1.000	25.400

FIGURE 6-6
FEET TO METERS CONVERSION TABLE
1 FOOT = 0.3048 METER

FEET	METERS	FEET	METERS	FEET	METERS	FEET	METERS	FEET	METERS
100	30.480	10	3.048	1	0.305	0.1	0.030	0.01	0.003
200	60.960	20	6.096	2	0.610	0.2	0.061	0.02	0.006
300	91.440	30	9.144	3	0.914	0.3	0.091	0.03	0.009
400	121.920	40	12.192	4	1.219	0.4	0.122	0.04	0.012
500	152.400	50	15.240	5	1.524	0.5	0.152	0.05	0.015
600	182.880	60	18.288	6	1.829	0.6	0.183	0.06	0.018
700	213.360	70	21.336	7	2.134	0.7	0.213	0.07	0.021
800	243.840	80	24.384	8	2.438	0.8	0.244	0.08	0.024
900	274.320	90	27.432	9	2.743	0.9	0.274	0.09	0.027
1,000	304.800	100	30.480	10	3.048	1.0	0.305	0.10	0.030

6

Appendix A

FIGURE 6-7
POUNDS TO KILOGRAMS CONVERSION TABLE
1 POUND = 0.4536 KILOGRAM

LB	KG	LB	KG	LB	KG	LB	KG	LB	KG
1,000...	453.59	100.....	45.36	10.....	4.54	1.....	0.45	0.1.....	0.05
2,000...	907.18	200.....	90.72	20.....	9.07	2.....	0.91	0.2.....	0.09
3,000...	1,360.78	300.....	136.08	30.....	13.61	3.....	1.36	0.3.....	0.14
4,000...	1,814.37	400.....	181.44	40.....	18.14	4.....	1.81	0.4.....	0.18
5,000...	2,267.96	500.....	226.80	50.....	22.68	5.....	2.27	0.5.....	0.23
6,000...	2,721.55	600.....	272.16	60.....	27.22	6.....	2.72	0.6.....	0.27
7,000...	3,175.15	700.....	317.51	70.....	31.75	7.....	3.18	0.7.....	0.32
8,000...	3,628.74	800.....	362.87	80.....	36.29	8.....	3.63	0.8.....	0.36
9,000...	4,082.33	900.....	408.23	90.....	40.82	9.....	4.08	0.9.....	0.41
10,000...	4,535.92	1,000.....	453.59	100.....	45.36	10.....	4.54	1.0.....	0.45

FIGURE 6-8
POUNDS PER SQUARE INCH TO BAR CONVERSION TABLE
1 PSI = 0.06895 BAR

PSI	BAR	PSI	BAR	PSI	BAR	PSI	BAR
1,000.....	68.95	100.....	6.90	10.....	0.69	1.....	0.07
2,000.....	137.90	200.....	13.79	20.....	1.38	2.....	0.14
3,000.....	206.84	300.....	20.68	30.....	2.07	3.....	0.21
4,000.....	275.80	400.....	27.58	40.....	2.76	4.....	0.28
5,000.....	344.70	500.....	34.47	50.....	3.45	5.....	0.35
6,000.....	413.64	600.....	41.36	60.....	4.14	6.....	0.41
7,000.....	482.58	700.....	48.26	70.....	4.83	7.....	0.48
8,000.....	551.52	800.....	55.15	80.....	5.52	8.....	0.55
9,000.....	620.46	900.....	62.05	90.....	6.21	9.....	0.62
10,000.....	689.48	1,000.....	68.95	100.....	6.90	10.....	0.69

FIGURE 6-9
POUNDS PER SQUARE INCH TO
KILOPASCALS CONVERSION TABLE
1 PSI = 6.895 kPa

PSI	kPa	PSI	kPa
10.....	68.95	1.....	6.90
20.....	137.90	2.....	13.79
30.....	206.84	3.....	20.68
40.....	275.80	4.....	27.58
50.....	344.70	5.....	34.47
60.....	413.64	6.....	41.36
70.....	482.58	7.....	48.26
80.....	551.52	8.....	55.15
90.....	620.46	9.....	62.05
100.....	689.48	10.....	68.95

Appendix A

FIGURE 6-10
FAHRENHEIT TO CELSIUS (Centigrade) CONVERSION TABLE
(DEGREES F - 32°) ÷ 1.8 = DEGREES C

deg F	deg C	deg F	deg C	deg F	deg C	deg F	deg C
1	-17.2	51	10.6	101	38.3	151	66.1
2	-16.7	52	11.1	102	38.9	152	66.7
3	-16.1	53	11.7	103	39.4	153	67.2
4	-15.6	54	12.2	104	40.0	154	67.8
5	-15.0	55	12.8	105	40.6	155	68.3
6	-14.4	56	13.3	106	41.1	156	68.9
7	-13.9	57	13.9	107	41.7	157	69.4
8	-13.3	58	14.4	108	42.2	158	70.0
9	-12.8	59	15.0	109	42.8	159	70.6
10	-12.2	60	15.6	110	43.3	160	71.1
11	-11.7	61	16.1	111	43.9	161	71.7
12	-11.1	62	16.7	112	44.4	162	72.2
13	-10.6	63	17.2	113	45.0	163	72.8
14	-10.0	64	17.8	114	45.6	164	73.3
15	-9.4	65	18.3	115	46.1	165	73.9
16	-8.9	66	18.9	116	46.7	166	74.4
17	-8.3	67	19.4	117	47.2	167	75.0
18	-7.8	68	20.0	118	47.8	168	75.6
19	-7.2	69	20.6	119	48.3	169	76.1
20	-6.7	70	21.1	120	48.9	170	76.7
21	-6.1	71	21.7	121	49.4	171	77.2
22	-5.6	72	22.2	122	50.0	172	77.8
23	-5.0	73	22.8	123	50.6	173	78.3
24	-4.4	74	23.3	124	51.1	174	78.9
25	-3.9	75	23.9	125	51.7	175	79.4
26	-3.3	76	24.4	126	52.2	176	80.0
27	-2.8	77	25.0	127	52.8	177	80.6
28	-2.2	78	25.6	128	53.3	178	81.1
29	-1.7	79	26.1	129	53.9	179	81.7
30	-1.1	80	26.7	130	54.4	180	82.2
31	-0.6	81	27.2	131	55.0	181	82.8
32	0.0	82	27.8	132	55.6	182	83.3
33	0.6	83	28.3	133	56.1	183	83.9
34	1.1	84	28.9	134	56.7	184	84.4
35	1.7	85	29.4	135	57.2	185	85.0
36	2.2	86	30.0	136	57.8	186	85.6
37	2.7	87	30.6	137	58.3	187	86.1
38	3.3	88	31.1	138	58.9	188	86.7
39	3.9	89	31.7	139	59.4	189	87.2
40	4.4	90	32.2	140	60.0	190	87.8
41	5.0	91	32.8	141	60.6	191	88.3
42	5.6	92	33.3	142	61.1	192	88.9
43	6.1	93	33.9	143	61.7	193	89.4
44	6.7	94	34.4	144	62.2	194	90.0
45	7.2	95	35.0	145	62.8	195	90.6
46	7.8	96	35.6	146	63.3	196	91.1
47	8.3	97	36.1	147	63.9	197	91.7
48	8.9	98	36.7	148	64.4	198	92.2
49	9.4	99	37.2	149	65.0	199	92.8
50	10.0	100	37.8	150	65.6	200	93.3

Appendix A

FIGURE 6-11
MILES PER HOUR TO KILOMETERS
PER HOUR CONVERSION TABLE
1 MPH = 1.609 KM/H

MPH	KM/H	MPH	KM/H	MPH	KM/H
10	16.09	1	1.61	0.1	0.16
20	32.19	2	3.22	0.2	0.32
30	48.28	3	4.83	0.3	0.48
40	64.37	4	6.44	0.4	0.64
50	80.47	5	8.05	0.5	0.80
60	96.56	6	9.66	0.6	0.97
70	112.65	7	11.27	0.7	1.13
80	128.75	8	12.87	0.8	1.29
90	144.84	9	14.48	0.9	1.45
100	160.93	10	16.09	1.0	1.61

FIGURE 6-12
U.S. GALLONS TO LITERS CONVERSION TABLE
1 U.S. GALLON = 3.785 LITERS

GAL	LITER	GAL	LITER	GAL	LITER	GAL	LITER
100	378.54	10	37.85	1	3.79	0.1	0.38
200	757.08	20	75.71	2	7.57	0.2	0.76
300	1,135.62	30	113.56	3	11.36	0.3	1.14
400	1,514.16	40	151.42	4	15.14	0.4	1.51
500	1,892.71	50	189.27	5	18.93	0.5	1.89
600	2,271.25	60	227.12	6	22.71	0.6	2.27
700	2,649.79	70	264.98	7	26.50	0.7	2.65
800	3,028.33	80	302.83	8	30.28	0.8	3.03
900	3,406.87	90	340.69	9	34.07	0.9	3.41
1,000	3,785.41	100	378.54	10	37.85	1.0	3.79

Appendix B

DISCLAIMER

HARSCO TRACK TECHNOLOGIES, HARSCO CORPORATION RECOMMENDS THAT ALL HOSE, HOSE ASSEMBLIES AND/OR FITTINGS REPLACED BY THE CUSTOMER SHOULD BE EQUAL TO OR EXCEED THE CURRENT SPECIFICATIONS OF THE ORIGINAL EQUIPMENT SUPPLIED BY HARSCO TRACK TECHNOLOGIES, HARSCO CORPORATION. HARSCO TRACK TECHNOLOGIES, HARSCO CORPORATION WILL NOT BE LIABLE FOR ANY CLAIMS OF PERSONAL INJURY RESULTING FROM THE USE OF HOSE, HOSE ASSEMBLIES AND/OR FITTINGS THAT DO NOT MEET CURRENT ORIGINAL EQUIPMENT SPECIFICATIONS. THE CUSTOMER IS ADVISED TO COMPLY WITH SAE J1273 NOVEMBER 1991, SELECTION, INSTALLATION, AND MAINTENANCE OF HOSE AND HOSE ASSEMBLIES.

SAE J1273 - NOVEMBER 1991*

SELECTION, INSTALLATION AND MAINTENANCE OF HOSE AND HOSE ASSEMBLIES

1. **SCOPE** - Hose (also includes hose assemblies) has a finite life and there are a number of factors which will reduce its life.

This SAE recommended practice is intended as a guide to assist system designers and/or users in the selection, installation, and maintenance of hose. The designers and users must make a systematic review of each application and then select, install, and maintain the hose to fulfill the requirements of the application. The following are general guidelines and are not necessarily a complete list.

6



- **IMPROPER SELECTION, INSTALLATION, OR MAINTENANCE MAY RESULT IN PREMATURE FAILURES, BODILY INJURY, OR PROPERTY DAMAGE.**

2. **REFERENCES**

- 2.1 **Applicable Documents** - The following publications form a part of this specification to the extent specified herein. The latest issue of SAE publications shall apply.

- 2.1.1 **SAE Publications** - Available from SAE, 400 Commonwealth Drive, Warrendale, PA 15096-0001.
J516 - Hydraulic Hose Fittings
J517 - Hydraulic Hose

3. **SELECTION** - The following is a list of factors which must be considered before final hose selection can be made.

- 3.1 **Pressure** - After determining the system pressure, hose selection must be made so that the recommended maximum operating pressure is equal to or greater than the system pressure. Surge pressures higher than the maximum operating pressure will shorten hose life and must be taken into account by the hydraulic designer.

Appendix B

- 3.2 Suction** - Hoses used for suction applications must be selected to insure the hose will withstand the negative pressure of the system.
- 3.3 Temperature** - Care must be taken to insure that fluid and ambient temperatures, both static and transient, do not exceed the limitations of the hose. Special care must be taken when routing near hot manifolds.
- 3.4 Fluid Compatibility** - Hose selection must assure compatibility of the hose tube, cover, and fittings with the fluid used. Additional caution must be observed in hose selection for gaseous applications.
- 3.5 Size** - Transmission of power by means of pressurized fluid varies with pressure and rate of flow. The size of the components must be adequate to keep pressure losses to a minimum and avoid damage to the hose due to heat generation or excessive turbulence.
- 3.6 Routing** - Attention must be given to optimum routing to minimize inherent problems.
- 3.7 Environment** - Care must be taken to insure that the hose and fittings are either compatible with or protected from the environment to which they are exposed. Environmental conditions such as ultraviolet light, ozone, salt water, chemicals, and air pollutants can cause degradation and premature failure, and, therefore, must be considered.
- 3.8 Mechanical Loads** - External forces can significantly reduce hose life. Mechanical loads which must be considered include excessive flexing, twist, kinking, tensile or side loads, bend radius, and vibration. Use of swivel type fittings or adapters may be required to insure no twist is put into the hose. Unusual applications may require special testing prior to hose selection.
- 3.9 Abrasion** - While a hose is designed with a reasonable level of abrasion resistance, care must be taken to protect the hose from excessive abrasion which can result in erosion, snagging and cutting of the hose cover. Exposure of the reinforcement will significantly accelerate hose failure.
- 3.10 Proper End Fitting** - Care must be taken to insure proper compatibility exists between the hose and coupling selected based on the manufacturer's recommendations substantiated by testing to industry standards such as SAE J517. End fitting components from one manufacturer are usually not compatible with end fitting components supplied by another manufacturer (i.e., using a hose fitting nipple from one manufacturer with a hose socket from another manufacturer). It is the responsibility of the fabricator to consult the manufacturer's written instructions or the manufacturer directly for proper end fitting componentry.

Appendix B

- 3.11 Length** - When establishing proper hose length, motion absorption, hose length changes due to pressure, as well as hose and machine tolerances must be considered.
- 3.12 Specifications and Standards** - When selecting hose, government, industry, and manufacturer's specifications and recommendations must be reviewed as applicable.
- 3.13 Hose Cleanliness** - Hose components vary in cleanliness levels. Care must be taken to insure that the assemblies selected have an adequate level of cleanliness for the application.
- 3.14 Electrical Conductivity** - Certain applications require that the hose be non-conductive to prevent electrical current flow. Other applications require the hose to be sufficiently conductive to drain off static electricity. Hose and fittings must be chosen with these needs in mind.
- 4. INSTALLATION** - After selection of proper hose, the following factors must be considered by the installer.
- 4.1 Pre-Installation Inspection** - Prior to installation, a careful examination of the hose must be performed. All components must be checked for correct style, size, and length. In addition, the hose must be examined for cleanliness, I.D. obstructions, blisters, loose cover, or any other visible defects.
- 4.2 Follow Manufacturers' Assembly Instructions** - Hose assemblies may be fabricated by the manufacturer, an agent for or customer of the manufacturer, or by the user. Fabrication of permanently attached fittings to hydraulic hose requires specialized assembly equipment. Field-attachable fittings (screw style and segment clamp style) can usually be assembled without specialized equipment although many manufacturers provide equipment to assist in this operation. SAE J517 hose from one manufacturer is not compatible with SAE J516 fittings supplied by another manufacturer. It is the responsibility of the fabricator to consult the manufacturer's written assembly instructions or the manufacturers directly before intermixing hose and fittings from two manufacturers. Similarly, assembly equipment from one manufacturer is usually not interchangeable with that of another manufacturer. It is the responsibility of the fabricator to consult the manufacturer's written instructions or the manufacturer directly for proper assembly equipment. Always follow the manufacturer's instructions for proper preparation and fabrication of hose assemblies.
- 4.3 Minimum Bend Radius** - Installation at less than minimum bend radius may significantly reduce hose life. Particular attention must be given to preclude sharp bending at the hose / fitting juncture.
- 4.4 Twist Angle and Orientation** - Hose installations must be such that relative motion of machine components produces bending of the hose rather than twisting.

Appendix B

- 4.5 Securement** - In many applications, it may be necessary to restrain, protect, or guide the hose to protect it from damage by unnecessary flexing, pressure surges, and contact with other mechanical components. Care must be taken to insure such restraints do not introduce additional stress or wear points.
- 4.6 Proper Connection of Ports** - Proper physical installation of the hose requires a correctly installed port connection while insuring that no twist or torque is put into the hose.
- 4.7 Avoid External Damage** - Proper installation is not complete without insuring that tensile loads, side loads, kinking, flattening, potential abrasion, thread damage, or damage to sealing surfaces are corrected or eliminated.
- 4.8 System Check Out** - After completing the installation, all air entrapment must be eliminated and the system pressurized to the maximum system pressure and checked for proper function and freedom from leaks.

Note: Avoid potential hazardous areas while testing.

Appendix B

5. **MAINTENANCE** - Even with proper selection and installation, hose life may be significantly reduced without a continuing maintenance program. Frequency should be determined by the severity of the application and risk potential. A maintenance program should include the following as a minimum.
- 5.1 **Hose Storage** - Hose products in storage can be affected adversely by temperature, humidity, ozone, sunlight, oils, solvents, corrosive liquids and fumes, insects, rodents and radioactive materials. Storage areas should be relatively cool and dark and free of dust, dirt, dampness, and mildew.
- 5.2 **Visual Inspection** - Any of the following conditions requires replacement of the hose:
- Leaks at fitting or in hose (leaking fluid is a fire hazard)
 - Damaged, cut, or abraded cover (any reinforcement exposed)
 - Kinked, crushed, flattened, or twisted hose
 - Hard, stiff, heat cracked, or charred hose
 - Blistered, soft degraded, or loose cover
 - Cracked, damaged, or badly corroded fittings
 - Fitting slippage on hose
- 5.3 **Visual Inspection** - The following items must be tightened, repaired, or replaced as required:
- Leaking port conditions
 - Clamps, guards, shields
 - Remove excessive dirt buildup
 - System fluid level, fluid type, and any air entrapment
- 5.4 **Functional Test** - Operate the system at maximum operating pressure and check for possible malfunctions and freedom from leaks.
- Note: Avoid potential hazardous areas while testing.*
- 5.5 **Replacement Intervals** - Specific replacement intervals must be considered based on previous service life, government or industry recommendations, or when failures could result in unacceptable down time, damage, or injury risk.

**SECTION 7 - PARTS
TABLE OF CONTENTS**

SERIAL NUMBERS 7 - 3

INSTRUCTIONS FOR ORDERING PARTS 7 - 4

LIMITED WARRANTY 7 - 5

PRODUCT IMPROVEMENT LIABILITY DISCLAIMER 7 - 5

HAZARDOUS MATERIAL DISCLAIMER 7 - 5

FRONT GUIDE WHEEL UNIT - 140142 7 - 6

HYDRAULIC PIPING - 140142 FRONT GUIDE WHEEL UNIT 7 - 10

REAR GUIDE WHEEL UNIT - 140177 7 - 12

HYDRAULIC PIPING - 140177 REAR GUIDE WHEEL UNIT 7 - 16

GUIDE WHEEL ASSEMBLY 7 - 17

RAIL SWEEP GROUP - 108480 7 - 18

STANDARD FRONT BRAKES / REAR UNIT BRAKE GROUP - 120977 7 - 20

AIR /HYDRAULIC BRAKE SYSTEM GROUP - 125475 7 - 22

REAR BRAKE CONNECTION - 121278 7 - 25

BRAKE CONTROL - 127084 7 - 25

STEERING LOCK GROUPS 7 - 25

TRUCK BRAKE CONNECTION

 154057 7 - 26

 154388 7 - 28

 154513 7 - 30

HYDRAULIC POWER PACK, FULL - 137926 7 - 32

HYDRAULIC POWER PACK, ABBREVIATED - 137927 7 - 36

SIGHT ROD EXTENSION GROUP - 164574 7 - 38

DECAL SERVICE GROUP - 154995 7 - 38

WHEEL MODIFICATION GROUP - 154064..... 7 - 39

MOUNTING BRACKET GROUPS

154062.....	7 - 40
154389.....	7 - 42
154540.....	7 - 44
154544.....	7 - 46
154550.....	7 - 48
155055.....	7 - 50
155062.....	7 - 52

Serial Numbers

When this bulletin is received, complete the following record from the serial number tags on both the front and rear guide wheel units. Always mention these factory serial numbers when calling or writing about the guide wheel units. The serial number tags are located on the frame mounting assemblies.

FRONT GUIDE WHEEL UNIT SERIAL NUMBER TAG

HTT Harsco Track Technologies a harsco company™		PATENT NUMBER <input type="text"/>
WHEN ORDERING PARTS FOR THIS ACCESSORY ALWAYS GIVE THE FOLLOWING INFORMATION		
Fairmont ™ HY-RAIL® GUIDE WHEEL EQUIPMENT		
SERIAL NUMBER	SYMBOL	MODEL NUMBER
<input type="text"/>	<input type="text"/>	<input type="text"/>
FAIRMONT, MN. 56031 U.S.A.		
52400K		

REAR GUIDE WHEEL UNIT SERIAL NUMBER TAG

HTT Harsco Track Technologies a harsco company™		PATENT NUMBER <input type="text"/>
WHEN ORDERING PARTS FOR THIS ACCESSORY ALWAYS GIVE THE FOLLOWING INFORMATION		
Fairmont ™ HY-RAIL® GUIDE WHEEL EQUIPMENT		
SERIAL NUMBER	SYMBOL	MODEL NUMBER
<input type="text"/>	<input type="text"/>	<input type="text"/>
FAIRMONT, MN. 56031 U.S.A.		
52400K		

Instructions For Ordering Parts

1. See Section 8 for the Vehicle Application charts.
2. Find the chart for the make, model and year of the vehicle that the unit is mounted on.
3. Each application consists of required groups, optional groups required and accessory group options. These are the group numbers that were supplied with, or that were available for the unit.
4. Locate the appropriate group numbers in the Parts Section to find the individual parts required.
5. Front - rear and left - right are determined from the operator's position.
6. Assemblies: Items listed in CAPITALS are assemblies which include all parts listed immediately following and with the part description indented to the right. When assemblies can be used, always order them to save work of fitting separate parts.
7. For convenience in ordering, parts are listed by item number, part number, description, and quantity in each assembly or group. If in doubt as to any part wanted, send full description, sketch, or send the old part with the order.
8. To insure prompt and correct shipment of parts on orders, always give:
 - a. Quantity of each part wanted.
 - b. Part number of each part as shown in this book. Include any prefix and suffix letters.
 - c. Description of each part as shown in this book.
 - d. Factory serial numbers recorded above.
 - e. Purchase order number (if required).
 - f. Preferred method of shipment.
9. All parts are shipped F.O.B. factory, transportation charges to be paid by customer. Terms to be determined by the Credit Department.

Limited Warranty

HARSCO TRACK TECHNOLOGIES products are designed to give high quality service and are manufactured from high grade material, by competent workmen under careful supervision. Harsco Track Technologies, Harsco Corporation warrants products of its manufacture to be free of defects in material and workmanship, under normal use and service for a period of six (6) months from date of delivery to the original user. The obligation of Harsco Track Technologies, Harsco Corporation under this warranty is limited to repairing or replacing at its factories, or other location designated by it, any part or parts thereof which are returned within 30 days of the date when failure occurs or defect is noted, with transportation charges prepaid, and which upon examination appears to the satisfaction of Harsco Track Technologies, Harsco Corporation to have been defective. Such free repair or replacement does not include transportation charges, or the cost of installing the new part or any other expense incident thereto. Harsco Track Technologies, Harsco Corporation will not be liable for other loss, damage, or expense directly or indirectly arising from the use of its products, nor will Harsco Track Technologies, Harsco Corporation be liable for special, incidental or consequential damages.

Ordinary wear and tear, and damage from abuse, misuse, neglect or alteration are not covered by this warranty. Harsco Track Technologies, Harsco Corporation assumes no liability for expenses incurred or repairs made outside its factories except by written consent. This warranty is null and void if instructions and operating procedures are not followed.

Equipment or parts not manufactured by this company, but which are furnished in connection with HARSCO TRACK TECHNOLOGIES products, are covered directly by the warranty of the manufacturer supplying them. However, Harsco Track Technologies, Harsco Corporation will assist in obtaining adjustment on such equipment or parts when necessary.

THIS WARRANTY IS IN LIEU OF ALL OTHER WARRANTIES EXPRESSED OR IMPLIED INCLUDING ANY IMPLIED WARRANTIES OF MERCHANTABILITY OR FITNESS FOR A PARTICULAR PURPOSE AND OF ANY OTHER OBLIGATION OR LIABILITY OF HARSCO TRACK TECHNOLOGIES, HARSCO CORPORATION.

Product Improvement Liability Disclaimer

HARSCO TRACK TECHNOLOGIES, HARSCO CORPORATION RESERVES THE RIGHT TO MAKE ANY CHANGES IN OR IMPROVEMENTS ON ITS PRODUCTS WITHOUT INCURRING ANY LIABILITY OR OBLIGATION WHATEVER AND WITHOUT BEING REQUIRED TO MAKE ANY CORRESPONDING CHANGES OR IMPROVEMENTS IN PRODUCTS PREVIOUSLY MANUFACTURED OR SOLD.

7

Hazardous Material Disclaimer

THE PARTS/ASSEMBLIES THAT ARE USED IN THIS PRODUCT ARE CLASSIFIED AS "ARTICLES" ACCORDING TO 29 CFR 1910.1200 (C). THEY ARE FORMED TO A SPECIFIC SHAPE OR DESIGN DURING MANUFACTURE, HAVE END USE FUNCTION DEPENDENT UPON THEIR SHAPE OR DESIGN, AND DO NOT RELEASE ANY HAZARDOUS CHEMICAL UNDER NORMAL CONDITIONS OF USE. ACCORDINGLY, WE ARE NOT REQUIRED TO SUPPLY MATERIAL SAFETY DATA SHEETS (MSDS) OR TO LABEL SHIPPING CONTAINERS FOR "ARTICLES". HOWEVER, LUBRICANTS, LIQUIDS, GASEOUS CHEMICALS AND SOLIDS USED IN OPERATION OR MAINTENANCE OF THE PRODUCT MAY REQUIRE THAT USER'S TAKE OCCUPATIONAL PROTECTIVE MEASURES. MSDS SHEETS FOR SUCH MATERIALS WILL BE SUPPLIED TO YOUR PURCHASING MANAGER/SAFETY DIRECTOR TO BE USED IN YOUR EMPLOYEE SAFETY TRAINING EDUCATION AND ENVIRONMENTAL HEALTH TRAINING.

140142 FRONT GUIDE WHEEL UNIT

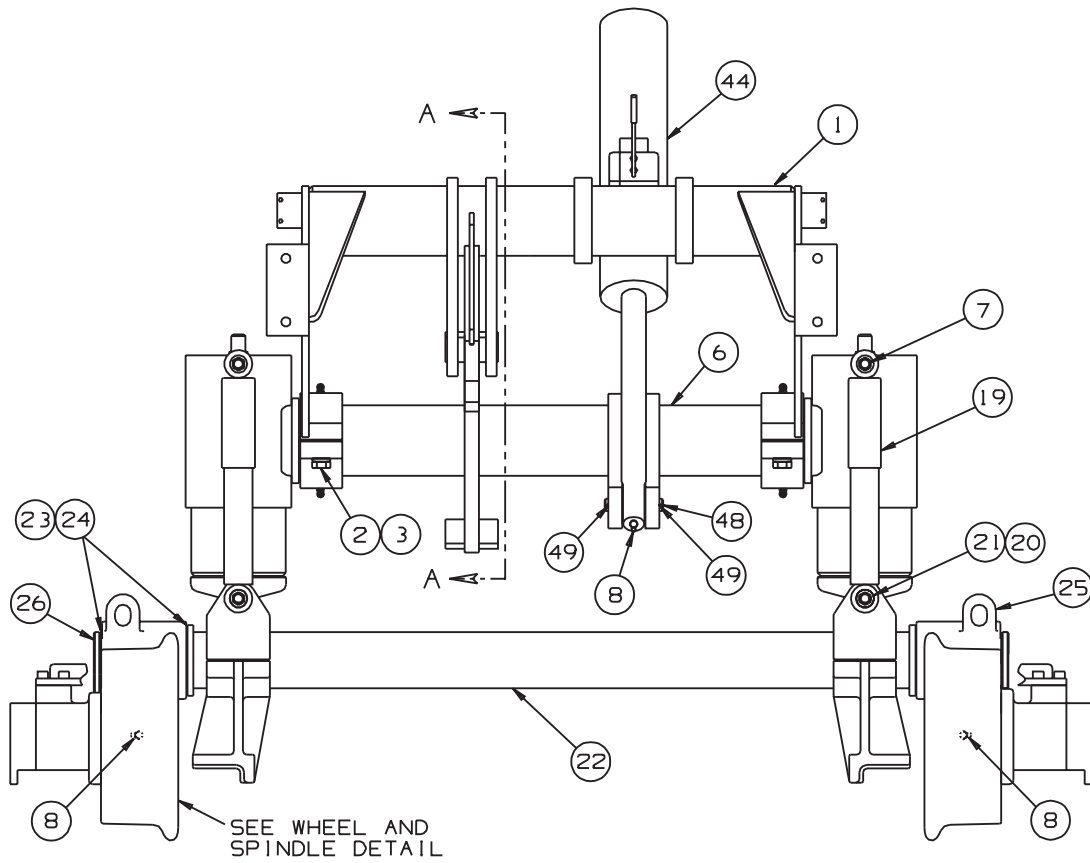
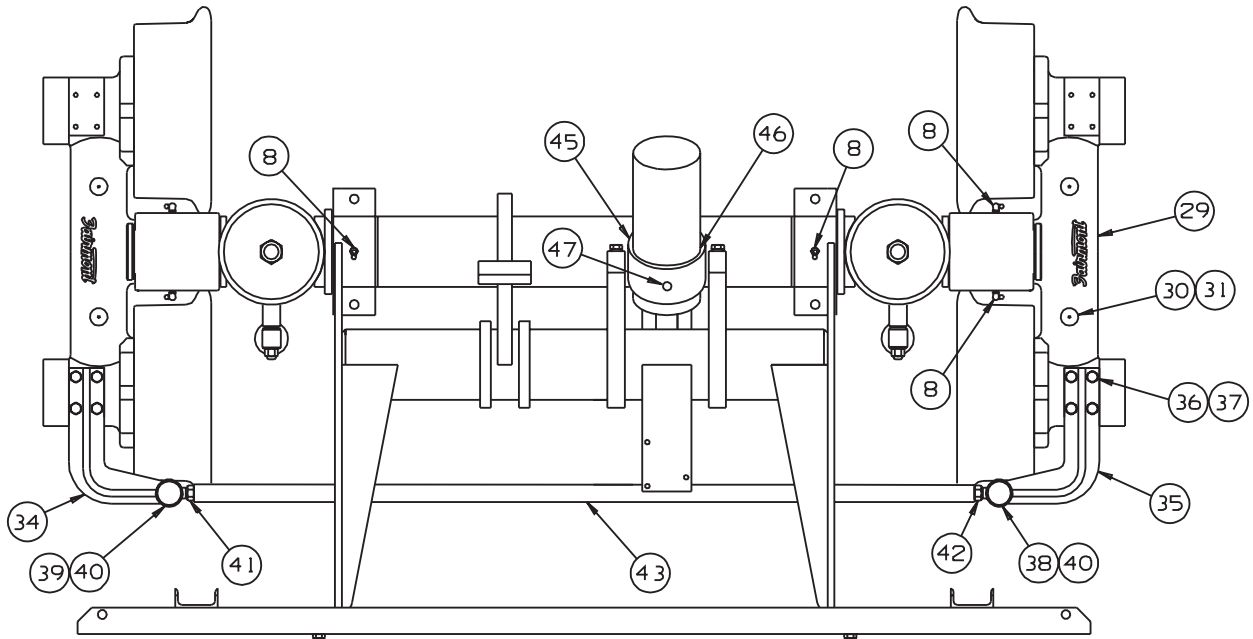

7

140142 FRONT GUIDE WHEEL UNIT

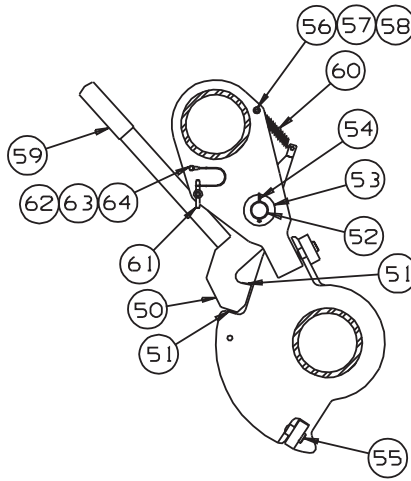

SECTION A - A

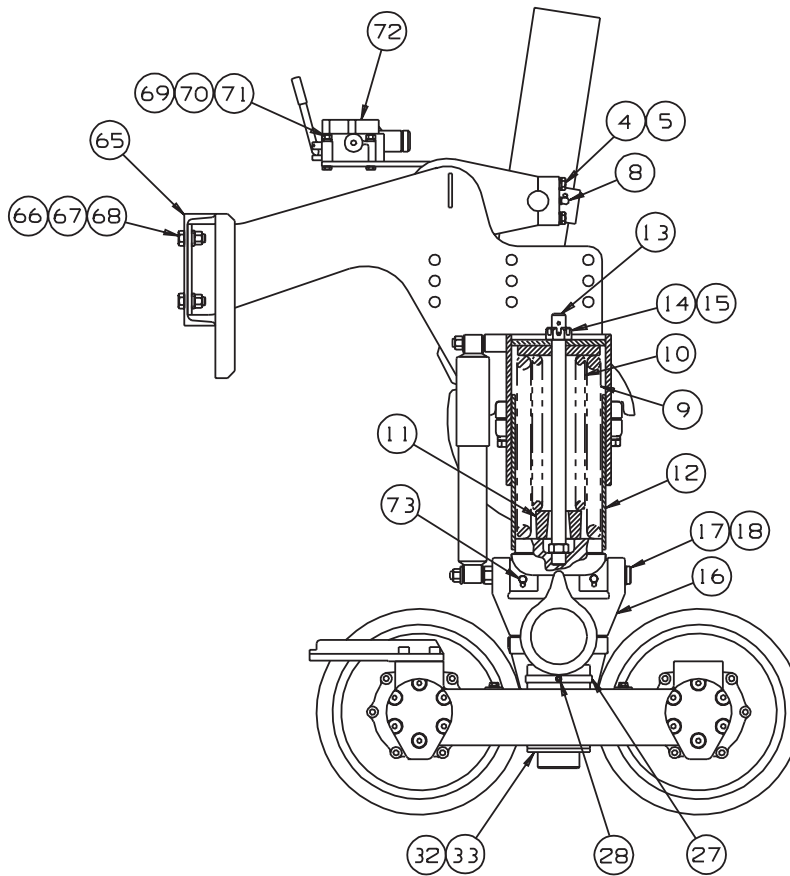

140142 FRONT GUIDE WHEEL UNIT

ITEM	PART NO	DESCRIPTION	QTY
1	140138	MOUNTING UNIT	1
2	F006382	Cap Screw, 3/4-10 x 2-1/2" GR 5 Hex Hd	2
3	F001354	SAE Lock Washer, 3/4"	2
4	F003095	Cap Screw, 1/2-13 x 2-3/4" GR 5 Hex Hd	2
5	F001683	SAE Lock Washer, 1/2"	2
6	140139	CROSS TUBE	1
7	F013239	Hex Lock Nut, 5/8"-18.	2
8	F009217	Grease Fitting, 90°	15
9	120247	Spring	2
10	120246	Spring	2
11	120286	Spacer	2
12	099373	Spring Housing.	2
13	111050	Adjusting Rod.	2
14	F006657	Hex Castle Nut, 1-14".	2
15	F004344	Cotter Pin, 3/16 x 2".	2
16	102089	Axle Clamp.	2
17	111052	Pin	2
18	F016475	Retaining Ring	4
19	105289K	Shock Absorber	2
20	M033847	Washer.	4
21	F013239	Hex Lock Nut, 5/8"-18	2
22	126838	Axle Tube.	1
23	099385	Spacer	4
24	117402	Spacer	4
25	111054K1	Swivel Bearing	2
26	F016477	Retaining Ring	2
27	102021	Thrust Bearing	2
28	F008014	Grease Fitting.	4
29	140158	Wheel Arm	2
30	F001007	Cap Screw, 3/8-16 x 1" GR 5.	4
31	F001025	SAE Lock Washer, 3/8"	4
32	135342	Washer.	2
33	F016315	Retaining Ring, 3"	2
34	139648	Tie Rod Arm, Right.	1
35	140112	Tie Rod Arm, Left.	1
36	F011713	Cap Screw, 1/2-13 x 1-1/2" Soc Hd	8
37	F012034	Lock Washer, 1/2"	8
38	F016663	Tie Rod End, Left.	1
39	F016664	Tie Rod End, Right.	1
40	F016665	Grease Seal	2
41	F010972	Hex Jam Nut, 3/4"-16.	1
42	F016246	Hex Jam Nut, 3/4"-16 Left Hand Threads	1
43	140126	Tie Rod.	1

140142 FRONT GUIDE WHEEL UNIT

ITEM	PART NO	DESCRIPTION	QTY
44	099394K	HYDRAULIC CYLINDER	1
	188632	Seal Kit	1
45	099402K	Cylinder Mounting	1
46	F016485	Retaining Ring	2
47	F014224	Set Screw, 3/8-16 x 3/8" Soc Cup Point, Locking	1
48	105030	Pin	1
49	F001182	Cotter Pin, 1/8 x 1-1/4"	2
50	154516	Lock Arm	1
51	113535	Spacer, .060"	4
52	140157	Lock Pin	1
53	M004458	Washer	6
54	F002547	Cotter Pin, 1/8 x 2"	2
55	F023736	Set Screw, 3/4-10 x 1-1/2" Soc Oval Point.	4
56	F007062	Cap Screw, 1/4-20 x 4" GR 5 Hex Hd	1
57	F009535	Lock Washer, 1/4"	1
58	F007022	Hex Nut, 1/4"-20 GR 5	1
59	F022846	Handle Grip	1
60	072909	Spring	1
61	F023737	Lockpin And Lanyard	1
62	F017061	Machine Screw, #4-40 x 1" Rd Hd	1
63	F022981	Lock Washer, #4	1
64	F010193	Hex Nut, #4-40 GR 2	1
65	111279	Bumper.	1
66	F003566	Cap Screw, 5/8-11 x 1-1/2" GR 5 Hex Hd	4
67	F001103	SAE Lock Washer, 5/8"	4
68	F007023	Hex Nut, 5/8"-11 GR 5	4
69	F013428	Cap Screw, 5/16-18 x 2-1/2" GR 5 Hex Hd	3
70	F001100	SAE Lock Washer, 5/16"	3
71	F007021	Hex Nut, 5/16"-18 GR 5	3
72	F018510	Control Valve	1
73	F004252	Grease Fitting, Straight	4

HYDRAULIC PIPING - 140142 FRONT GUIDE WHEEL UNIT

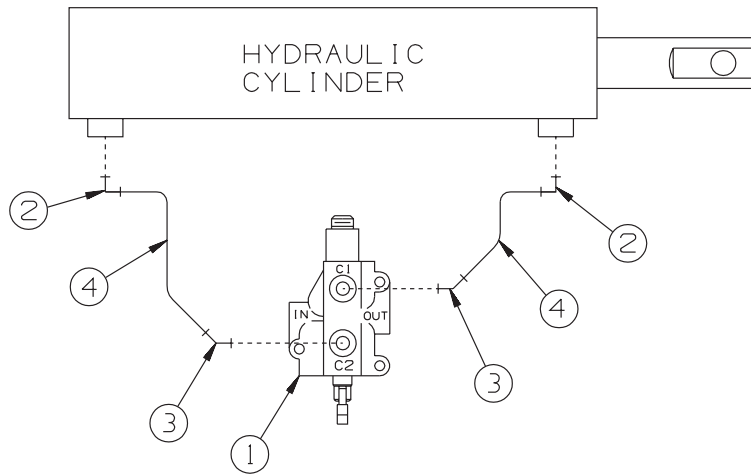

SE130461A-2

ITEM	PART NO	DESCRIPTION	QTY
1	F018510	Control Valve	1
2	F010987	90° Elbow	2
3	F018562	45° Elbow	2
4	061356	Hose	2

140177 REAR GUIDE WHEEL UNIT

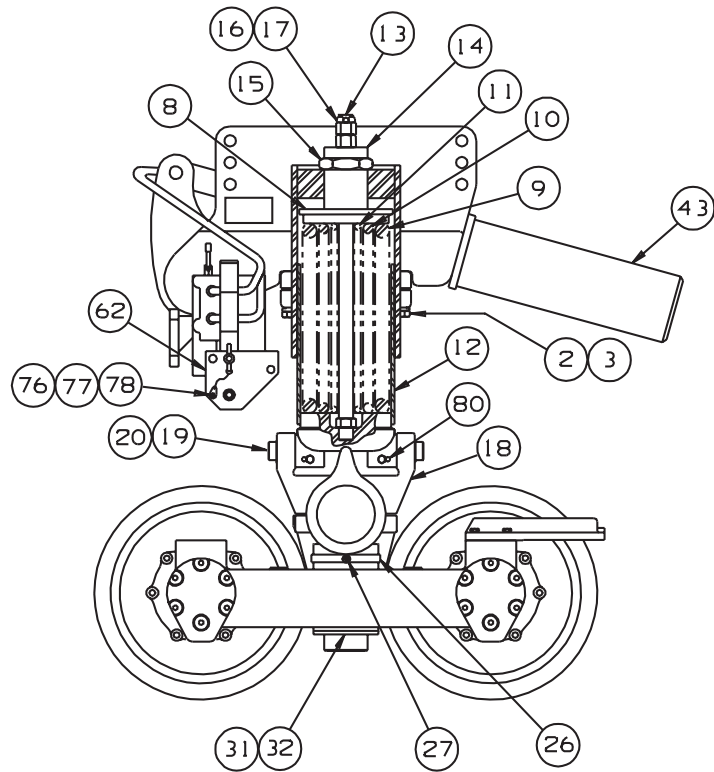
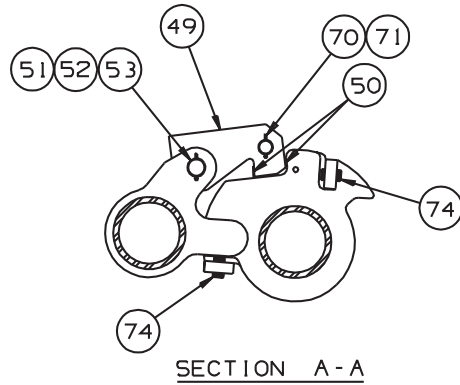

140177 REAR GUIDE WHEEL UNIT

ITEM	PART NO	DESCRIPTION	QTY
1	139637	MOUNTING UNIT	1
2	F006382	Cap Screw, 3/4-10 x 2-1/2" GR 5 Hex Hd	2
3	F001354	SAE Lock Washer, 3/4"	2
4	140166	CROSS TUBE	1
5	F003095	Cap Screw, 1/2-13 x 2-3/4" GR 5 Hex Hd	2
6	F001075	SAE Lock Washer, 1/2"	2
7	F009217	Grease Fitting, 90°	15
8	099369	Washer.	2
9	099370	Spring	2
10	099371	Spring	2
11	140109	Spring	2
12	099373	Spring Housing.	2
13	111065	Adjusting Rod.	2
14	111067	Adjusting Stud	2
15	099378	Hex Nut, 3"	2
16	F006657	Hex Castle Nut, 1"-14.	2
17	F004344	Cotter Pin, 3/16 x 2"	2
18	102089	Axle Clamp.	2
19	111069	Clamp Pin.	2
20	F016475	Retaining Ring	4
21	126838	Axle Tube	1
22	099385	Spacer, 1/8"	4
23	117402	Spacer, .060"	4
24	111054K1	Swivel Bearing	2
25	F016477	Retaining Ring	2
26	102021	Thrust Bearing	2
27	F008014	Grease Fitting.	6
28	140158	Wheel Arm	2
29	F001007	Cap Screw, 3/8-16 x 1" GR 5 Hex Hd	4
30	F001025	SAE Lock Washer, 3/8"	4
31	135342	Washer.	2
32	F016315	Retaining Ring, 3"	2
33	139648	Tie Rod Arm, Left.	1
34	140112	Tie Rod Arm, Right.	1
35	F011713	Cap Screw, 1/2-13 x 1-1/2" Soc Hd	8
36	F012034	Lock Washer, 1/2"	8
37	F016663	Tie Rod End, Right.	1
38	F016664	Tie Rod End, Left	1
39	F016665	Grease Seal	2
40	F010972	Hex Jam Nut, 3/4"-16 GR 2	1
41	F016246	Hex Jam Nut, 3/4"-16 Left Hand Threads	1
42	140126	Tie Rod.	1

140177 REAR GUIDE WHEEL UNIT

ITEM	PART NO	DESCRIPTION	QTY
43	099394K	HYDRAULIC CYLINDER	1
	188632	Seal Kit	1
44	099402K	Cylinder Mount	1
45	F016485	Retaining Ring	2
46	F014224	Set Screw, 3/8-16 x 3/8" Soc Cup Point, Locking	1
47	105030	Pin	1
48	F001182	Cotter Pin, 1/8 x 1-1/4"	2
49	136276	Lock Arm	1
50	113535	Shim	4
51	140157	Lock Arm Pin	1
52	M004458	Washer	6
53	F002547	Cotter Pin, 1/8 x 2"	2
54	126420	Bracket	1
55	F019634	Cap Screw, 1/2-13 x 1-3/4" Flt Soc Hd	2
56	F001075	SAE Lock Washer, 1/2"	2
57	F003598	Hex Nut, 1/2"-13 GR 5	2
58	F013428	Cap Screw, 5/16-18 x 2-1/2" GR 5 Hex Hd	3
59	F001100	SAE Lock Washer, 5/16"	3
60	F007021	Hex Nut, 5/16"-18 GR 5	3
61	140145	Lock Handle	1
62	116030	Bracket	1
63	F001442	Cap Screw, 1/2-13 x 2" GR 5 Hex Hd	2
64	F001075	SAE Lock Washer, 1/2"	2
65	F003598	Hex Nut, 1/2"-13 GR 5	2
66	069859	Sleeve	2
67	140175	Lock Yoke	1
68	M033360K1	Yoke Rod End	1
69	F005460	Yoke Pin	1
70	140176	Pin	1
71	F001104	Cotter Pin, 1/8 x 1"	2
72	089216	Link	1
73	M010612	Spring	1
74	F023736	Set Screw, 3/4-10 x 1-1/2" Oval Pt Soc Hd	4
75	081645K	Lockpin And Lanyard	1
76	F009591	Machine Screw, #10-24 x 3/4" Rd Hd	1
77	F009541	SAE Lock Washer, #10	1
78	F009542	Hex Nut, #10-24 GR 2	1
79	F022846	Handle Grip	1
80	F004252	Grease Fitting	4
81	F018510	Control Valve	1

HYDRAULIC PIPING - 140177 REAR GUIDE WHEEL UNIT

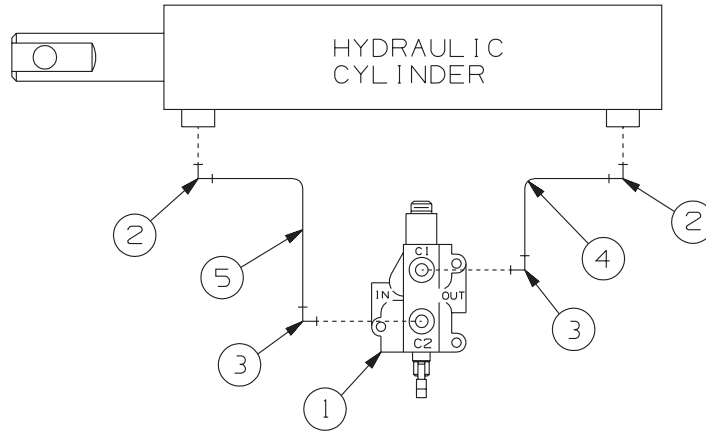

SE124058A-2

ITEM	PART NO	DESCRIPTION	QTY
1	F018510	Control Valve	1
2	F010987	90° Elbow	2
3	F012055	90° Elbow	2
4	188659	Hose	1
5	188660	Hose	1

GUIDE WHEEL ASSEMBLY

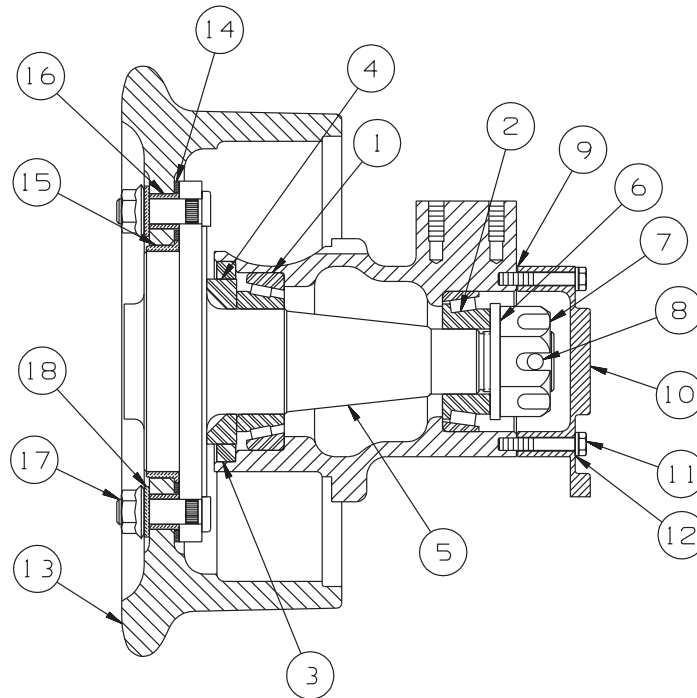

SE140177A-3

Note: Quantities listed are for one wheel only.

ITEM	PART NO	DESCRIPTION	QTY
1	099539	Bearing Cup And Cone, Outside	1
2	099540	Bearing Cup And Cone, Inside.	1
3	F016480	Grease Seal	1
4	099386	Ring	1
5	153731	SPINDLE ASSEMBLY	1
	F016577	Wheel Bolt	8
6	F006497	Washer, 3" O.D.	1
7	F013840	Hex Slotted Nut, 1-1/2"-12	1
8	F008264	Cotter Pin, 3/8 x 2-1/2"	1
9	103907	Gasket	1
10	102091K1	Hub Cap	1
11	F009663	Cap Screw, 5/16-18 x 2" GR 5 Hex Hd	6
12	F001100	SAE Lock Washer, 5/16"	6
13	113969	Guide Wheel, 12-1/2" DIA.	1
14	082653	Insulating Washer	1
15	082654	Insulating Flange	1
16	082655	Insulating Bushing	8
17	F020917	Hex Flg Nut, 5/8"-18.	8
18	065203	Insulating Washer	8

108480 RAIL SWEEP GROUP

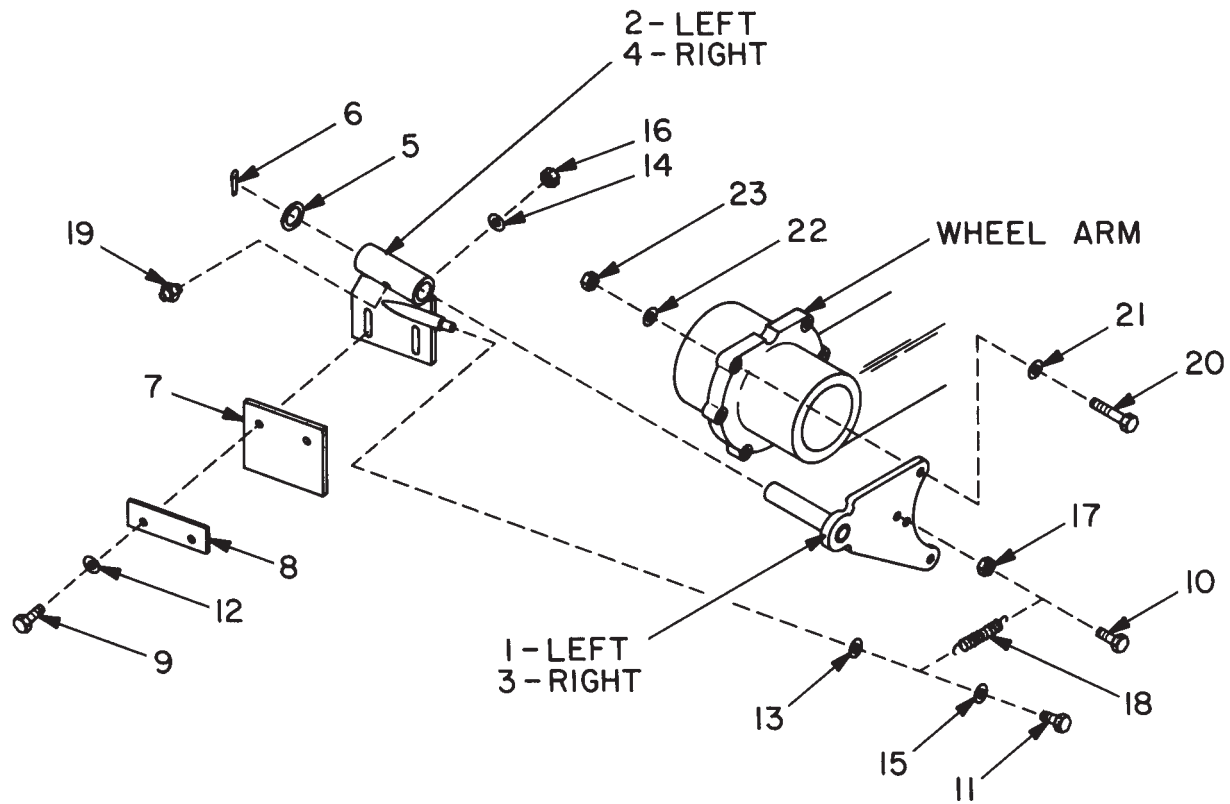

SE108480A-1

108480 RAIL SWEEP GROUP

ITEM	PART NO	DESCRIPTION	QTY
	108501	RAIL SWEEP ASSEMBLY, LEFT	1
1	108502	Mounting Bracket, Left	1
2	108505	Rail Sweep Plate, Left	1
5	179117	Washer	1
6	F003141	Cotter Pin, 1/8 x 1-1/2"	1
7	108509K1	Rail Sweep	1
8	108510	Rail Sweep Plate	1
9	F001125	Cap Screw, 3/8-16 x 1-1/4" GR 5 Hex Hd	2
10	F001113	Cap Screw, 5/16-18 x 1-1/4" GR 5	1
11	F002355	Cap Screw, 1/4-20 x 3/4" GR 5 Hex Hd	1
12	F001115	Wrought Washer, 3/8"	2
13	F001106	Wrought Washer, 1/4"	1
14	F001025	SAE Lock Washer, 3/8"	2
15	F009535	Lock Washer, 1/4"	1
16	F007020	Hex Nut, 3/8"-16 GR 5	2
17	F007021	Hex Nut, 5/16"-18 GR 5	1
18	072909	Spring	1
19	F008014	Grease Fitting	1
	108511	RAIL SWEEP ASSEMBLY, RIGHT	1
3	108512	Mounting Bracket, Right	1
4	108513	Rail Sweep Plate, Right	1
5	179117	Washer	1
6	F003141	Cotter Pin, 1/8 x 1-1/2"	1
7	108509K1	Rail Sweep	1
8	108510	Rail Sweep Plate	1
9	F001125	Cap Screw, 3/8-16 x 1-1/4" GR 5 Hex Hd	2
10	F001113	Cap Screw, 5/16-18 x 1-1/4" GR 5	1
11	F002355	Cap Screw, 1/4-20 x 3/4" GR 5 Hex Hd	1
12	F001115	Wrought Washer, 3/8"	2
13	F001106	Wrought Washer, 1/4"	1
14	F001025	SAE Lock Washer, 3/8"	2
15	F009535	Lock Washer, 1/4"	1
16	F007020	Hex Nut, 3/8"-16 GR 5	2
17	F007021	Hex Nut, 5/16"-18 GR 5	1
18	072909	Spring	1
19	F008014	Grease Fitting	1
20	F009668	Cap Screw, 3/8-16 x 2-1/4" GR 5 Hex Hd	6
21	F001115	Wrought Washer, 3/8"	6
22	F001025	SAE Lock Washer, 3/8"	6
23	F007020	Hex Nut, 3/8"-16 GR 5	6

**STANDARD FRONT BRAKES
120977 REAR UNIT BRAKE GROUP**

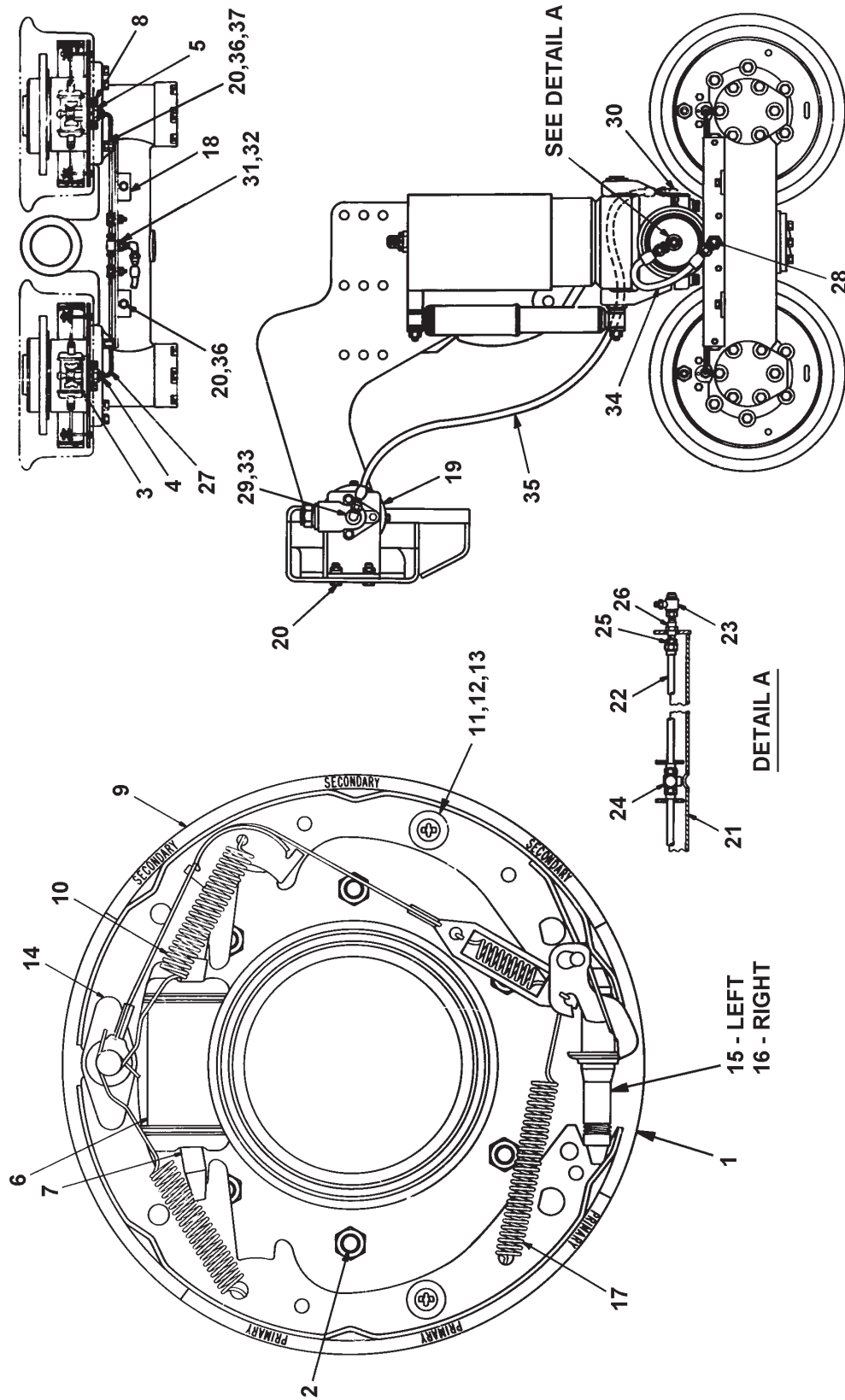

**STANDARD FRONT BRAKES
120977 REAR UNIT BRAKE GROUP**

ITEM	PART NO	DESCRIPTION	QTY
1	116779	Plate Assembly	4
2	F001024	Cap Screw, 3/8-16 x 1-1/2" GR 5 Hex Hd	20
	F001025	SAE Lock Washers, 3/8"	20
3	116782	Bar	4
4	116783	Stud	4
	F002782	SAE Lock Washer, 9/16"	4
5	F016453	Hex Nut, 9/16"-18 GR 5	4
6	F018892K	Wheel Cylinder	4
7	F018893	Piston Rod	8
	F009535	Lock Washer, 1/4"	8
8	F009825	Cap Screw, 1/4-20 x 1" GR 5 Hex Hd	8
9	F018894	Brake Shoe Set (2 Primary Shoes & 2 Secondary Shoes)	2
10	F018895	Return Spring Set (4 Springs)	2
11	F020741	Hold Down Pin	8
12	F020742	Hold Down Spring	8
13	F020743	Hold Down Retainer	16
14	F018897	Plate	4
15	F018900	Auto Adjuster, Left (Adjuster, Cable and Lever)	2
16	F018901	Auto Adjuster, Right (Adjuster, Cable and Lever)	2
17	F018902	Adjuster Spring Set (2 Adjuster Springs)	2
18	135343	Brake Tube Mounting Bracket	2
19	F021928	Power Cluster	1
20	F001007	Cap Screw, 3/8-16 x 1" GR 5 Hex Hd	12
	116798	BRAKE TUBING SUPPORT BRACKET ASSEMBLY	1
21	116799	Tubing Support Assembly	1
22	116802	Tubing Assembly	2
23	F018903	90° Swivel Fitting	2
	F019397	Seal Kit	2
24	F011120	Tee	1
25	F010994	Adapter	2
26	F012898	Coupling	2
27	116787	Brake Tube Assembly	4
28	F010677	90° Elbow	2
29	F010912	90° Elbow	1
30	F013477	90° Elbow	1
31	F016039	Tee	2
32	F001737	Coupling	2
33	F011132	Plug	1
34	097200	Hose	2
35	116794	Hose	1
36	F001025	SAE Lock Washer, 3/8"	12
37	F007020	Hex Nut, 3/8"-16 GR 5	8

125475 AIR / HYDRAULIC BRAKE SYSTEM GROUP

ITEM	PART NO	DESCRIPTION	QTY
1	F025423	Air Compressor	1
2	F009910	Air Reservoir	1
3	F021954K	Hand Brake Control	1
	F014389K	MOISTURE EJECTION VALVE	1
4	F017679	Automatic Drain Valve	1
5	F022777	90° Elbow	1
6	146353	90° Elbow	1
7	F010683	Adapter	1
8	134935	Bracket	1
9	134934	Plate	1
10	F009667	Cap Screw, 1/4-20 x 1-1/2" GR 5 Hex Hd	2
11	F013588	Elastic Stop Nut, 1/4"-20	2
12	F006584	90° Street Elbow	1
13	F015447	Check Valve	1
14	F011937	90° Elbow	4
15	F015809	Tee	1
16	F011079	Adapter	2
17	F012205	90° Elbow	1
18	F008551	Pipe Plug	1
	140375	HOSE GROUP	1
19	F010590	Hose, 3/16 x 300" (cut to length)	1
20	F020714	Hose Fitting (use on hose F010590)	5
21	089445	Hose	1
22	116421	Hose	1
23	116424	Hose	1
24	F019402	Pressure Switch	1
25	F014874	Cable Grip	1
26	F013279	Conduit Lock Nut	1
27	F019374	Snap-In Blank	1
28	F014406	Circuit Breaker	1
29	F016227	Machine Screw, #10-24 x 1" Rd Hd	3
30	F009541	SAE Lock Washer #10	3
31	F009542	Hex Nut, #10-24 GR 2	3
32	F017311	Grommet	1
33	F010683	Adapter	1
34	F019403	Tee	1
35	F010181	Drain Valve	1
36	F011009	Tee	1
37	F010144	Relief Valve	1
38	F013373	Adapter	1
39	F016904	Pressure Reducing Valve	1
40	F015104	90° Elbow	1
41	F010674	Tee	1

125475 AIR / HYDRAULIC BRAKE SYSTEM GROUP

ITEM	PART NO	DESCRIPTION	QTY
42	161888	Cover	1
43	F016656	Ty-Rap (not shown, use as required).	12
44	126684	Air Reservoir Mounting Bar	2
45	F022776	Air Reservoir Mounting Bracket	2
46	125484	Ejection Valve Mounting Angle	1
47	F001099	Cap Screw, 5/16-18 x 1" Hex Hd	2
48	F001122	Cap Screw, 5/16-18 x 1-1/2" GR 5 Hex Hd	4
49	F012888	Cap Screw, 5/16-18 x 2-3/4" GR 5 Hex Hd	2
50	F001362	Wrought Washer, 5/16"	4
51	F001100	SAE Lock Washer, 5/16"	6
52	F007021	Hex Nut, 5/16"-18 GR 5	6
53	F001539	Cap Screw, 1/2-13 x 1-1/4" GR 5 Hex Hd	2
54	F001075	SAE Lock Washer, 1/2"	2
55	F003598	Hex Nut, 1/2"-13 GR 5	2
56	F001007	Cap Screw, 3/8-16 x 1" GR 5	4
57	F001025	SAE Lock Washer, 3/8"	4
58	F007020	Hex Nut, 3/8"-16 GR 5	4

121278 REAR BRAKE CONNECTION

PART NO	DESCRIPTION	QTY
F011260	Tee	1
F010988	90° Elbow.....	1
140374	HOSE GROUP.....	1
F010693	Hose, 5/16 x 360" (cut to length)	1
F011392	Hose Fitting (use on hose F010693)	2
F018064	Hose Fitting (use on hose F010693)	2

127084 BRAKE CONTROL

PART NO	DESCRIPTION	QTY
131908	Plate	1
F011562	Cap Screw, 3/8-16 x 3/4" Flt Soc Hd	2
F001125	Cap Screw, 3/8-16 x 1-1/4" GR 5 Hex Hd	2
F001025	SAE Lock Washer, 3/8"	2
127295	Bar	1
F012316	45° Elbow.....	3

STEERING LOCK GROUPS

Individual steering lock components are not available as repair parts. Steering lock groups are sold as complete replacement groups only. See vehicle application charts to find the correct steering lock group applicable to your make, model and year of vehicle.

154057 TRUCK BRAKE CONNECTION

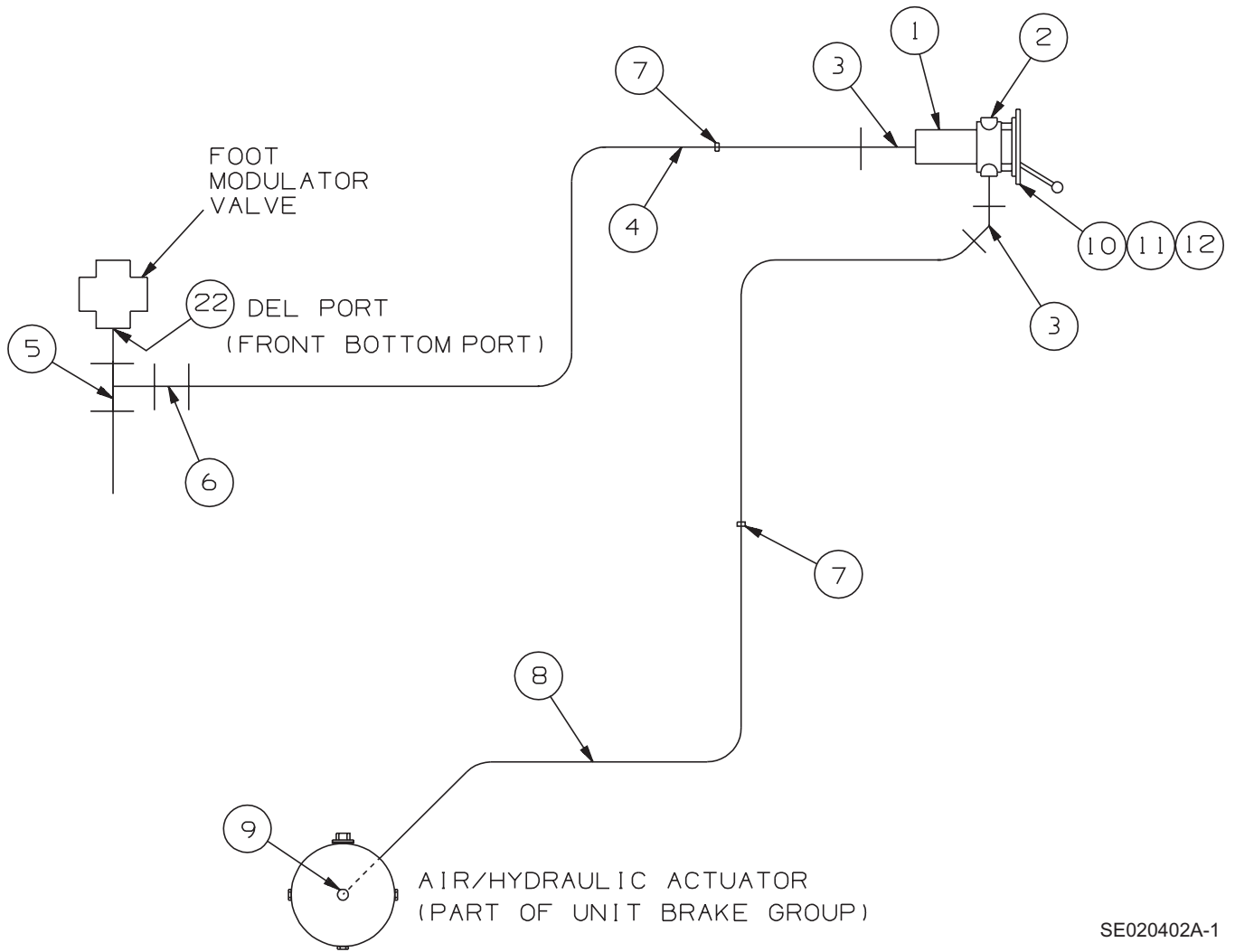

SE020402A-1

154057 TRUCK BRAKE CONNECTION

ITEM	PART NO	DESCRIPTION	QTY
1	F019332	Air Control Valve	1
2	F010989	Pipe Plug, 1/4 M NPT.	1
3	F011117	45° Elbow, 9/16 M JIC x 1/4 M NPT.	2
4	F018904	Hose, 5/16 x 48" Swivel 9/16 F JIC Both Ends	1
5	F013684	Tee, 3/8 M NPT x 3/8 F NPT x 3/8 F NPT	1
6	F012056	Adapter, 9/16 M JIC x 3/8 M NPT	1
7	F012587	Grommet	2
8	154058	HOSE GROUP	1
8a	F010693	Hose, 5/16" I.D.	180"
8b	F011392	Swivel Hose Fitting, 9/16 F JIC.	2
9	F010988	90° Elbow, 9/16 M JIC x 1/4 M NPT.	1
10	122583	Instruction Plate, Rail Wheel.	1
11	F009591	Machine Screw, #10-24 x 3/4" Rd Hd	2
12	120457	Decal, Rail Brake Operation.	1
13	120453	Bracket.	1

154388 TRUCK BRAKE CONNECTION

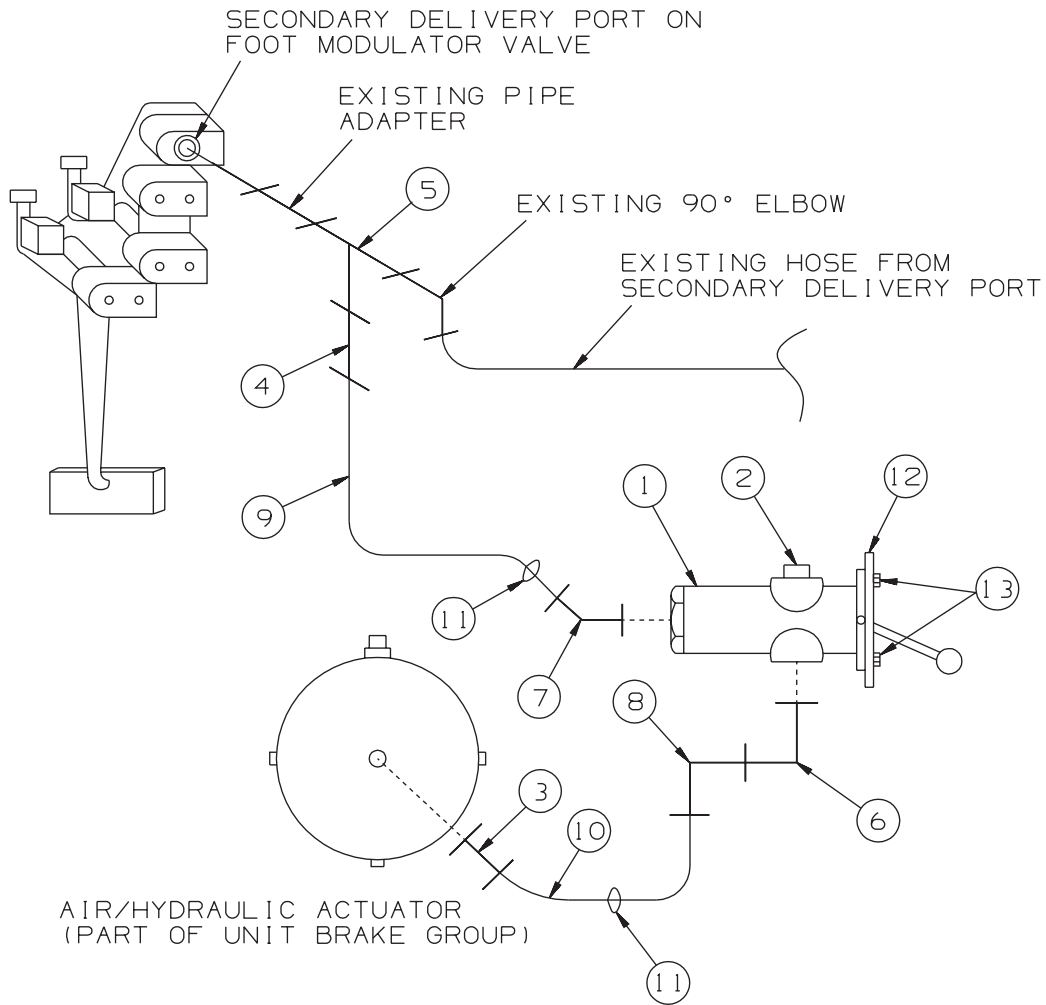

SE020442A-1

154388 TRUCK BRAKE CONNECTION

ITEM	PART NO	DESCRIPTION	QTY
1	F019332	Air Control Valve	1
2	F010989	Pipe Plug	1
3	F010994	Adapter.	2
4	F012056	Adapter.	1
5	F013684	Tee	1
6	F010988	90° Elbow.....	2
7	F011117	45° Elbow.....	1
8	F012808	90° Elbow.....	1
9	F018904	Hose	1
10	160190	Hose	1
11	F012587	Grommet	2
12	122583	Instruction Plate, Rail Wheel.....	1
13	F009591	Machine Screw, #10-24 x 3/4" Rd Hd	2
	120453	Bracket.....	1
	120457	Decal, Rail Brake Operation (mount on dash)	1
	F016578	Ty-Rap (use as required)	10

154513 TRUCK BRAKE CONNECTION

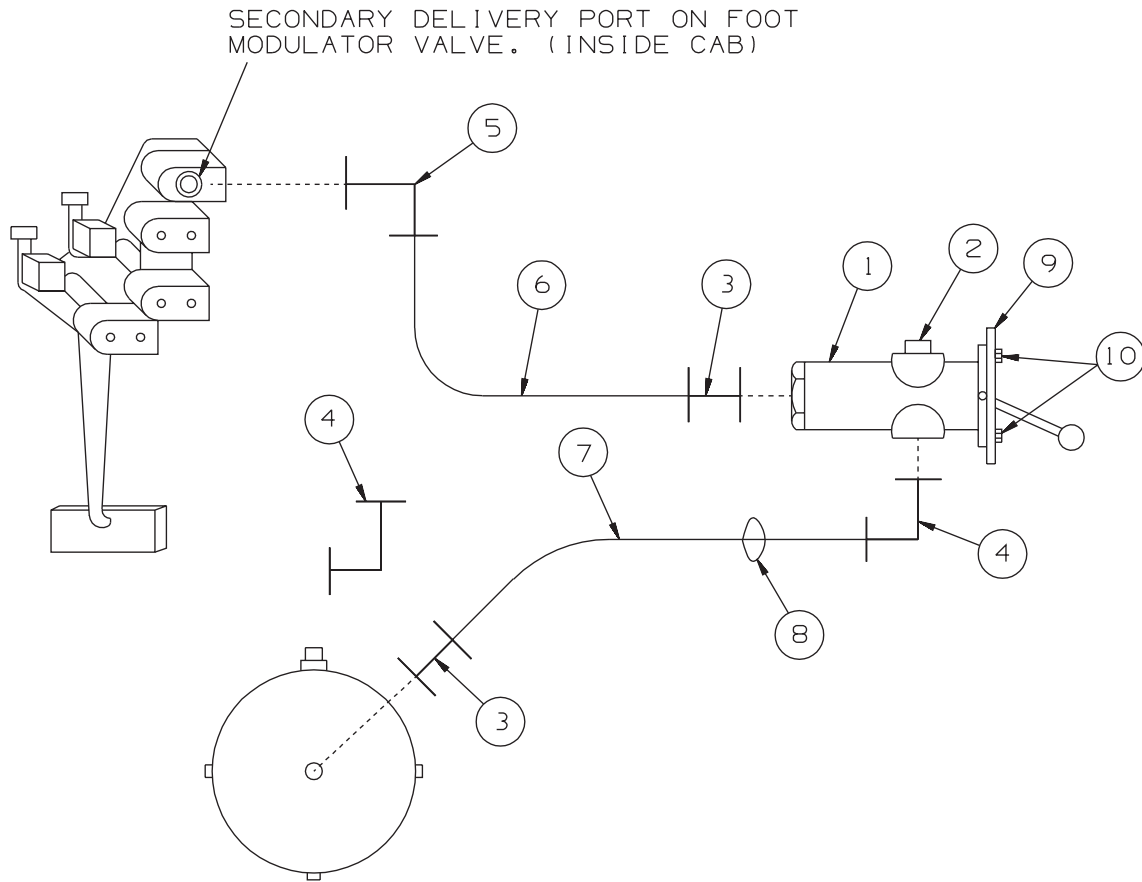

AIR/HYDRAULIC ACTUATOR
(PART OF UNIT BRAKE GROUP)

SE020451A-1

154513 TRUCK BRAKE CONNECTION

ITEM	PART NO	DESCRIPTION	QTY
1	F019332	Air Control Valve	1
2	F010989	Pipe Plug	1
3	F010994	Adapter.	2
4	F010988	90° Elbow	2
5	F012055	90° Elbow	1
6	160593	Hose	1
7	170852	Hose	1
8	F012587	Grommet	2
9	122583	Instruction Plate, Rail Wheel.....	1
10	F009591	Machine Screw, #10-24 x 3/4" Rd Hd	2
	120453	Bracket.	1
	120457	Decal, Rail Brake Operation (mount on dash)	1
	F016578	Ty-Rap (use as required)	10

137926 HYDRAULIC POWER PACK - FULL

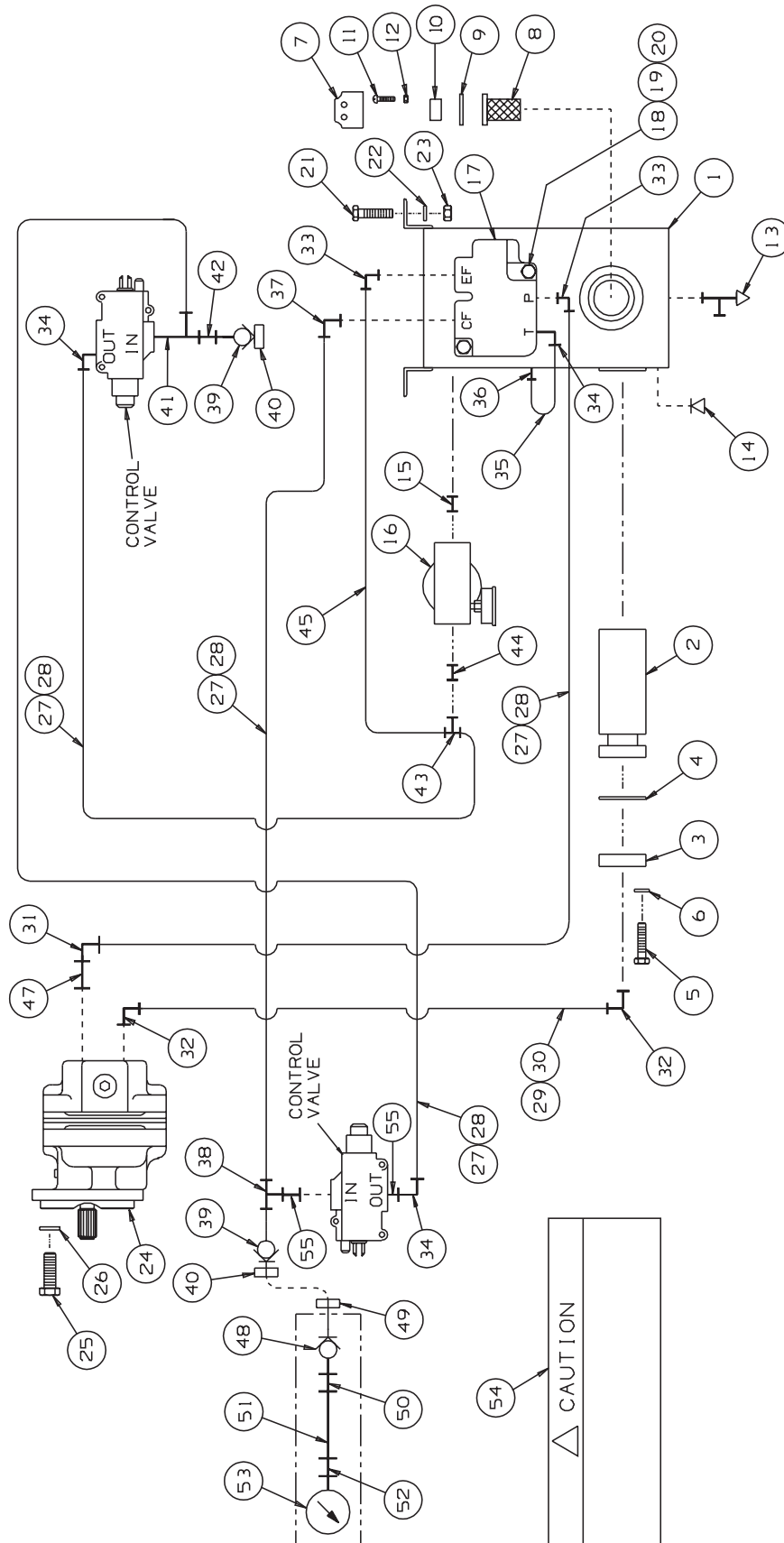

7

137926 HYDRAULIC POWER PACK - FULL

ITEM	PART NO	DESCRIPTION	QTY
	137926	HYDRAULIC POWER PACK -FULL	1
	129136	HYDRAULIC RESERVOIR ASSEMBLY	1
1	099444	Reservoir Only.	1
2	F014155	Filter	1
3	082205	Filter Flange	1
4	077997	Flange Gasket.	1
5	F001125	Cap Screw, 3/8-16 x 1-1/4" Hex Hd	4
6	F001025	SAE Lock Washer, 3/8"	4
7	F022655	FILLER CAP	1
8	F010465	Filler Screen	1
9	056780	Filler Flange Gasket	2
10	F010466	Filler Flange.	1
11	F009723	Machine Screw, 10-24 x 3/8" Rd Hd	6
12	F009541	SAE Lock Washer, #10	6
13	F010181	Drain Valve, 1/8 M NPT.	2
14	F012702	Pipe Plug, 3/8 M NPT Magnetic	1
15	F001328	Pipe Nipple, 3/4 M NPT x 1-3/8"	1
16	F015452	FILTER - RETURN	1
16a	F015453	Replacement Filter Element	1
17	120993	VALVE, FLOW DIVIDER.	1
17a	F019415	Pressure Relief Washers (set of four)	1
18	F009663	Cap Screw, 5/16-18 x 2" Hex Hd.	2
19	F007021	Hex Nut, 5/16"-18.	2
20	F001100	SAE Lock Washer, 5/16"	2
21	F001125	Cap Screw, 3/8-16 x 1-1/4" Hex Hd	4
22	F001025	SAE Lock Washer, 3/8"	4
23	F007020	Hex Nut, 3/8"-16	4
24	F023330	Hydraulic Pump	1
25	F003136	Cap Screw, 1/2-13 x 1" Hex Hd	2
26	F001075	SAE Lock Washer, 1/2"	2
	140344	HOSE GROUP	1
27	F009947	Hose, 13/32 x 960" (cut to length).	1
28	F020713	Hose Fitting, Swivel 3/4 F JIC (install on hose F009947)	8
29	F010298	Hose, 1-1/8 x 75" (cut to length)	1
30	F014307	Hose Fitting, Swivel 1-5/8 F JIC (install on hose F010298)	2
31	F013243	90° Elbow, 3/4 M NPT x 3/4 M JIC	1
32	F021260	90° Elbow, 1 M NPT x 1-5/8 M JIC	2
33	F012054	90° Elbow, 1/2 M NPT x 3/4 M JIC	2
34	F011114	90° Elbow, 3/8 M NPT x 3/4 M JIC	3
35	067736	Hose, 13/32 x 17" Swivel 3/4 F JIC Both Ends.	1
36	F011170	Adapter, 3/8 M NPT x 3/4 M JIC.	1
37	F012704	90° Elbow, 3/4 M JIC x 3/8 M NPT	1

137926 HYDRAULIC POWER PACK - FULL

ITEM	PART NO	DESCRIPTION	QTY
38	F013605	Tee, 3/4 M JIC x 3/8 M NPT x 3/8 M NPT	1
39	F015303K	Nose Piece, 3/8 F NPT	2
40	F015077	Dust Cap.	2
41	F014722	Tee, 3/8 F NPT x 3/4 M JIC x 3/8 M NPT	1
42	F011604	Adapter, 3/8 M NPT x 3/8 M NPT	1
43	F013629	Tee, 3/4 M JIC x 3/4 M JIC x 3/8 M NPT	1
44	F012024	Reducer Bushing, 3/4 M NPT x 3/8 F NPT	1
45	067736	Hose, 13/32 x 17" Swivel 3/4 F JIC Both Ends	1
47	F011617	Reducer Bushing, 1 M NPT x 3/4 F NPT	1
	099137K	PRESSURE GAUGE ASSEMBLY	1
48	F015110K	Body, 3/8 F NPT	1
49	F015111	Dust Cap	1
50	F012056	Adapter, 3/8 M NPT x 9/16 M JIC	1
51	171878	Hose, 3/8 x 14" Swivel 9/16 F JIC Both Ends	1
52	F011109	Adapter, 9/16 M JIC x 1/4 F NPT	1
53	F011432K	Pressure Gauge, 1/4 M NPT	1
54	137941	Decal, Caution -Recommended....	1
55	F015103	Adapter, 3/8 F NPT x 3/4 M STR (used on vertical units only).	2

137927 HYDRAULIC POWER PACK - ABBREVIATED

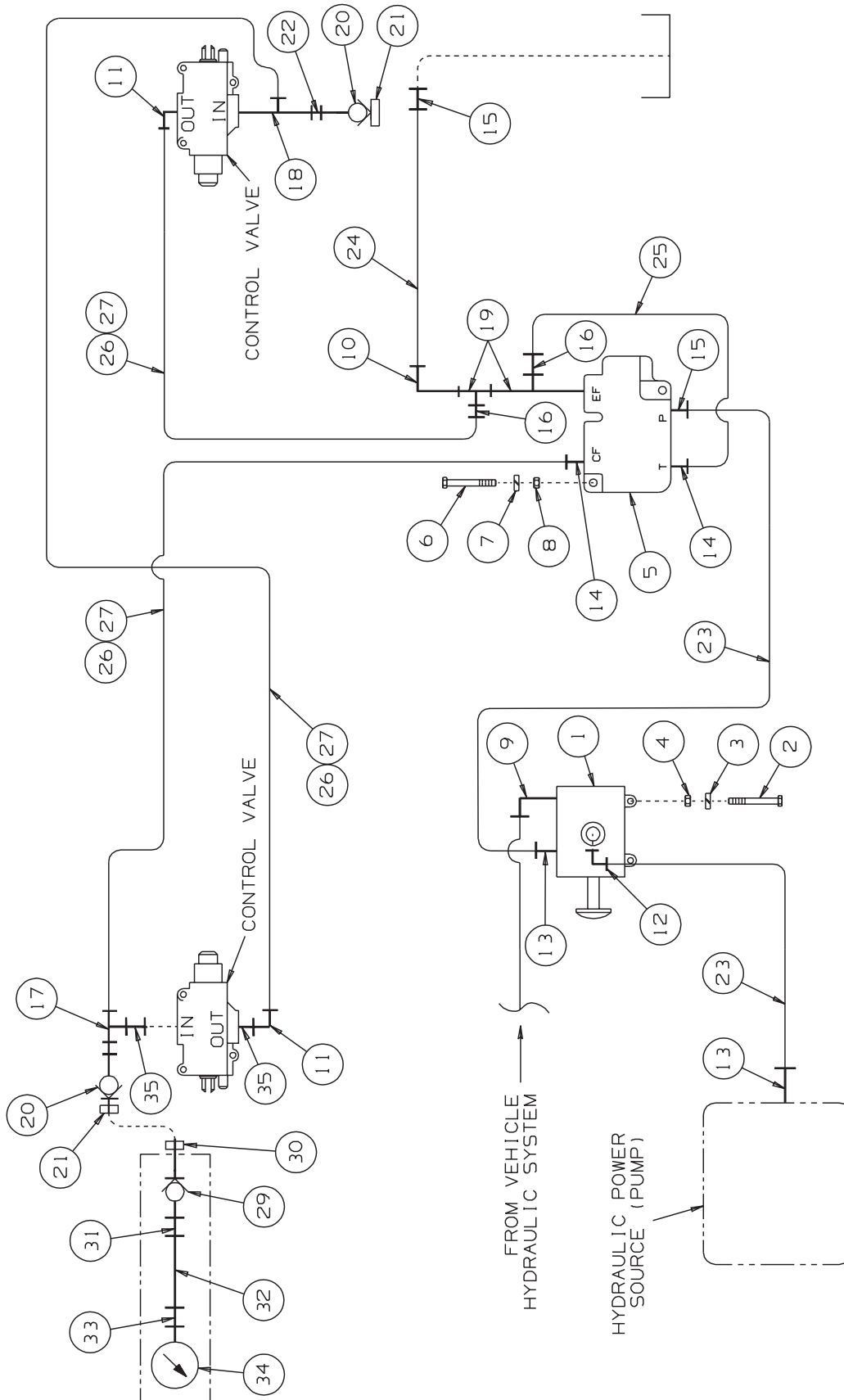

137927 HYDRAULIC POWER PACK - ABBREVIATED

ITEM	PART NO	DESCRIPTION	QTY
	137927	HYDRAULIC POWER PACK -ABBREVIATED	1
1	F016490	Selector Valve	1
2	F002760	Cap Screw, 3/8-16 x 2-1/4" Hex Hd	2
3	F001025	SAE Lock Washer, 3/8"	2
4	F009670	Hex Grip Nut, 3/8"-16	2
5	120993	VALVE, FLOW DIVIDER	1
	F019415	Pressure Relief Washers (set of four)	1
6	F009663	Cap Screw, 5/16-18 x 2" Hex Hd	2
7	F001100	SAE Lock Washer, 5/16"	2
8	F007021	Hex Nut, 5/16"-18	2
9	F012010	90° Elbow Street, 3/4 F NPT x 3/4 M NPT	1
10	F010584	90° Elbow, 1-1/16 M JIC x 1/2 M NPT	1
11	F011114	90° Elbow, 3/4 M JIC x 3/8 M NPT	2
12	F010586	90° Elbow, 1-1/16 M JIC x 3/4 M NPT	1
13	F010581	Adapter, 1-1/16 M JIC x 3/4 M NPT	2
14	F011170	Adapter, 3/4 M JIC x 3/8 M NPT	2
15	F013210	Adapter, 1-1/16 M JIC x 1/2 M NPT	2
16	F012027	Adapter, 3/4 M JIC x 1/2 M NPT	2
17	F013605	Tee, 3/4 M JIC x 3/8 M NPT x 3/8 M NPT	1
18	F014722	Tee, 3/8 F NPT x 3/4 M JIC x 3/8 M NPT	1
19	F010692	Tee, 1/2 F NPT x 1/2 M NPT x 1/2 F NPT	2
20	F015303K	Nose Piece, 3/8 F NPT	2
21	F015077	Dust Cap	2
22	F011604	Adapter, 3/8 M NPT x 3/8 M NPT	1
23	071692	Hose, 5/16 x 48" Swivel 1-1/16 F JIC Both Ends	2
24	111100	Hose, 3/4 x 28" Swivel 1-1/16 F JIC Both Ends	1
25	071867	Hose, 1/2 x 19-3/4" Swivel 3/4 F JIC Both Ends	1
	140345	HOSE GROUP	1
26	F009947	Hose, 13/32 x 960" (cut to length)	1
27	F020713	Hose Fitting, Swivel 3/4 F JIC (install on hose F009947)	6
	099137K	PRESSURE GAUGE ASSEMBLY	1
29	F015110K	Body, 3/8 F NPT	1
30	F015111	Dust Cap	1
31	F012056	Adapter, 3/8 M NPT x 9/16 M JIC	1
32	171878	Hose, 3/8 x 14" Swivel 9/16 F JIC Both Ends	1
33	F011109	Adapter, 9/16 M JIC x 1/4 F NPT	1
34	F011432K	Pressure Gauge, 1/4 M NPT	1
35	F015103	Adapter, 3/8 F NPT x 3/4 M STR (used on vertical units only)	2

164574 SIGHT ROD EXTENSION GROUP

PART NO	DESCRIPTION	QTY
164574	SIGHT ROD EXTENSION GROUP	1
130195	Sight Rod Kit (includes two sight rods).....	1
135809	Sight Rod Extension	2
161855	Mounting Bar	2
F022036	Cap Screw, 1/2-13 x 1-1/4" Hex Flg Hd	2
F022037	Hex Flg Nut, 1/2"-13	2

154995 DECAL SERVICE GROUP

PART NO	DESCRIPTION	QTY
154995	DECAL SERVICE GROUP	1
F018082	Decal, Safety Instructions: Lock Front Wheels... ..	1
F018083	Decal, Axle Lock Instructions	2
F018084	Decal, Operation.	2
140220	Decal, Warning: Do Not Operate.....	3
140366	Decal, Operating Instructions	1
155007	Decal, HY-RAIL® Vehicle Completed By... ..	1

154064 WHEEL MODIFICATION GROUP

PART NO	DESCRIPTION	QTY
154064	WHEEL MODIFICATION GROUP	1
F016379	Spacer Wedge Ring	4
F014925	Spacer Band	4

154062 MOUNTING BRACKET GROUP

PART NO	DESCRIPTION	QTY
154062	MOUNTING BRACKET GROUP	1

Parts For Front Unit Mounting

154393	Shim, 1/8" (use as required)	2
154394	Shim, 16 ga. (use as required)	2
F006382	Cap Screw, 3/4-10 x 2-1/2" GR 5 Hex Hd	6
F001354	SAE Lock Washer, 3/4"	6
F013695	Hex Nut, 3/4"-10 GR 5	6
154052	Spacer Block, Left.	1
155037	Spacer Block, Right	1
F005454	Cap Screw, 5/8-11 x 5-1/2" GR 5 Hex Hd	3
F001103	SAE Lock Washer, 5/8"	6
F007023	Hex Nut, 5/8"-11 GR 5	6
F020458	Cap Screw, 3/4-10 x 2-1/2" GR 8 Hex Hd	2
M022621	Pivot Plate Spacer	2
F021137	Hardened Washer.	2
F023375	Hex Flg Nut, 3/4"-10 GR 8	2
130458	Axle Hook Arm	1
130608	Axle Hook Arm	1
130457	Axle Hook	2
F007941	Cap Screw, 5/8-11 x 5" GR 5 Hex Hd.	3
F015807	Cap Screw, 5/8-18 x 1-3/4" GR 5 Hex Hd	4
F020917	Hex Flg Nut, 5/8"-18	4
154061	Pull Rod, Right	1
154060	Pull Rod, Left	1
126411	Bracket	2
F011954	Spring Pin 3/8 x 1-1/2"	4
F020598	Spring	2
F020964	Collar	2
F009825	Cap Screw, 1/4-20 x 1" GR 5 Hex Hd.	4
F009535	Lock Washer, 1/4".	4
F007022	Hex Nut, 1/4"-20 GR 5	4
F001267	Wrought Washer, 1/2".	2
F001104	Cotter Pin, 1/8 x 1"	2
F014260K	Ball Handle	2
020466	Front Unit Application Drawing	

154062 MOUNTING BRACKET GROUP

PART NO	DESCRIPTION	QTY
154062	MOUNTING BRACKET GROUP	1

Parts For Rear Unit Mounting

154391	Shim, 1/8" (use as required)	4
154392	Shim, 16 ga. (use as required)	4
F006382	Cap Screw, 3/4-10 x 2-1/2" GR 5 Hex Hd	4
F018833	Cap Screw, 3/4-10 x 2-1/2" Flt Hd	2
F001354	SAE Lock Washer, 3/4"	6
F013695	Hex Nut, 3/4"-10 GR 5	6
F007986	Cap Screw, 3/4-10 x 3" GR 5 Hex Hd.	4
F024283	Cap Screw, 3/4-10 x 3" Flt Hd	2
126412	Wheel Stop Bracket, Left	1
126415	Wheel Stop Bracket, Right	1
124610	Wheel Stop Support	2
F010812K	Bumper	2
F018861	Cap Screw, 1/2-13 x 2-1/4" GR 8 Hex Hd	6
F022037	Hex Flg Nut, 1/2"-13 GR 5	6
F020460	Cap Screw, 5/8-11 x 2" GR 8 Hex Hd.	2
F021924	Hex Flg Nut, 5/8"-11 GR 5	2
F018650	Cap Screw, 1/2-13 x 1-1/2" GR 8 Hex Hd	4
F001075	SAE Lock Washer, 1/2"	4
F018812	Hex Nut, 1/2"-13 GR 8	4
F001007	Cap Screw, 3/8-16 x 1" GR 5 Hex Hd.	4
F001025	SAE Lock Washer, 3/8"	4
F007020	Hex Nut, 3/8"-16 GR 5	4
020467	Rear Unit Application Drawing	

154389 MOUNTING BRACKET GROUP

PART NO	DESCRIPTION	QTY
154389	MOUNTING BRACKET GROUP	1

Parts For Front Unit Mounting

154393	Shim, 1/8" (use as required)	2
154394	Shim, 16 ga. (use as required)	2
F006382	Cap Screw, 3/4-10 x 2-1/2" GR 5 Hex Hd	6
F001354	SAE Lock Washer, 3/4"	6
F013695	Hex Nut, 3/4"-10 GR 5	6
154100	Side Bar, Right	1
154101	Side Bar, Left	1
F023743	Cap Screw, 5/8-11 x 5-1/2" GR 8 Hex Hd	6
F016378	Cap Screw, 5/8-11 x 3-1/2" GR 8 Hex Hd	6
F019503	Hex Nut, 5/8"-11 GR 8	12
F001103	SAE Lock Washer, 5/8"	12
117633	Axle Hook	2
F020458	Cap Screw, 3/4-10 x 2-1/2" GR 8 Hex Hd	2
F023375	Hex Flg Nut, 3/4"-10 GR 8	2
M022621	Pivot Plate Spacer	2
F021137	Hardened Washer	2
F001753	Wrought Washer, 3/4"	4
130620	Pull Rod	1
130621	Pull Rod	1
F001267	Wrought Washer, 1/2"	2
F001104	Cotter Pin, 1/8 x 1"	2
126411	Bracket	2
F011954	Spring Pin, 3/8 x 1-1/2"	4
F009825	Cap Screw, 1/4-20 x 1" GR 5 Hex Hd	4
F009535	Lock Washer, 1/4"	4
F007022	Hex Nut, 1/4"-20 GR 5	4
F020964	Collar	2
F020598	Spring	2
F014260K	Ball Handle	2
020436	Front Unit Application Drawing	

154389 MOUNTING BRACKET GROUP

PART NO	DESCRIPTION	QTY
154389	MOUNTING BRACKET GROUP	1

Parts For Rear Unit Mounting

154391	Shim, 1/8" (use as required)	4
154392	Shim, 16 ga. (use as required)	4
F006382	Cap Screw, 3/4-10 x 2-1/2" GR 5 Hex Hd	4
F018833	Cap Screw, 3/4-10 x 2-1/2" Flt Hd	2
F001354	SAE Lock Washer, 3/4"	6
F013695	Hex Nut, 3/4"-10 GR 5	6
126412	Wheel Stop Bracket, Left	1
126415	Wheel Stop Bracket, Right	1
124610	Wheel Stop Support	2
F010812K	Bumper	2
F018861	Cap Screw, 1/2-13 x 2-1/4" GR 8 Hex Hd	8
F018812	Hex Nut, 1/2"-13 GR 8	8
F001075	SAE Lock Washer, 1/2"	8
F001090	Cap Screw, 1/2-13 x 1-1/2" GR 5 Hex Hd	4
F022037	Hex Flg Nut, 1/2"-13 GR 5	4
F001007	Cap Screw, 3/8-16 x 1" GR 5 Hex Hd	4
F001025	SAE Lock Washer, 3/8"	4
F007020	Hex Nut, 3/8"-16 GR 5	4
020437	Rear Unit Application Drawing	

154540 MOUNTING BRACKET GROUP

PART NO	DESCRIPTION	QTY
154540	MOUNTING BRACKET GROUP	1

Parts For Front Unit Mounting

154393	Shim, 1/8" (use as required)	2
154394	Shim, 16 ga. (use as required)	2
F006382	Cap Screw, 3/4-10 x 2-1/2" GR 5 Hex Hd	6
F001354	SAE Lock Washer, 3/4"	6
F013695	Hex Nut, 3/4"-10 GR 5	6
154561	Side Bar	2
154562	Spacer	2
F001304	Cap Screw, 5/8-11 x 2" GR 5 Hex Hd.	4
F022712	Cap Screw, 5/8-18 x 3" GR 8 Hex Hd.	4
F022173	Cap Screw, 3/4-10 x 2" Hex Hd	2
F021926	Hex Flg Nut, 3/4"-10 GR 5	2
154505	Axle Hook Bracket	1
154508	Axle Hook Bracket	1
F005454	Cap Screw, 5/8-11 x 5-1/2" GR 5 Hex Hd	6
F021924	Hex Flg Nut, 5/8"-11 GR 5	10
130458	Hook Arm	2
F020458	Cap Screw, 3/4-10 x 2-1/2" GR 8 Hex Hd	2
M022621	Pivot Plate Spacer	2
F001753	Wrought Washer, 3/4".	2
F023375	Hex Flg Nut, 3/4"-10 GR 8	2
130457	Axle Hook	2
F015807	Cap Screw, 5/8-18 x 1-3/4" GR 5 Hex Hd	4
F020917	Hex Flg Nut, 5/8"-18	4
125789	Pull Rod	2
F001267	Wrought Washer, 1/2".	2
F001104	Cotter Pin, 1/8 x 1"	2
F020964	Collar	2
126411	Bracket	2
F011954	Spring Pin, 3/8 x 1-1/2".	4
F009825	Cap Screw, 1/4-20 x 1" GR 5 Hex Hd.	4
F009535	Lock Washer, 1/4".	4
F007022	Hex Nut, 1/4"-20 GR 5	4
F020598	Spring	2
F014260K	Ball Handle	2
020468	Front Unit Application Drawing	

154540 MOUNTING BRACKET GROUP

PART NO	DESCRIPTION	QTY
154540	MOUNTING BRACKET GROUP	1

Parts For Rear Unit Mounting

154391	Shim, 1/8" (use as required)	4
154392	Shim, 16 ga. (use as required)	4
F006382	Cap Screw, 3/4-10 x 2-1/2" GR 5 Hex Hd	4
F018833	Cap Screw, 3/4-10 x 2-1/2" Flt Hd	2
F001354	SAE Lock Washer, 3/4"	6
F013695	Hex Nut, 3/4"-10 GR 5	6
154510	Channel (frame extension, weld on)	2
F007986	Cap Screw, 3/4-10 x 3" GR 5 Hex Hd.	4
F024283	Cap Screw, 3/4-10 x 3" Flt Hd	2
126412	Wheel Stop Bracket, Left	1
126415	Wheel Stop Bracket, Right	1
124610	Wheel Stop Support	2
F018861	Cap Screw, 1/2-13 x 2-1/4" GR 8 Hex Hd	8
F022037	Hex Flg Nut, 1/2"-13 GR 5	8
F018650	Cap Screw, 1/2-13 x 1-1/2" GR 8 Hex Hd	4
F001075	SAE Lock Washer, 1/2"	4
F018812	Hex Nut, 1/2"-13 GR 8	4
F010812K	Bumper	2
F001007	Cap Screw, 3/8-16 x 1" GR 5 Hex Hd.	4
F001025	SAE Lock Washer, 3/8"	4
F007020	Hex Nut, 3/8"-16 GR 5	4
020469	Rear Unit Application Drawing	

154544 MOUNTING BRACKET GROUP

PART NO	DESCRIPTION	QTY
154544	MOUNTING BRACKET GROUP	1

Parts For Front Unit Mounting

154393	Shim, 1/8" (use as required)	2
154394	Shim, 16 ga. (use as required)	2
F006382	Cap Screw, 3/4-10 x 2-1/2" GR 5 Hex Hd	6
F001354	SAE Lock Washer, 3/4"	6
F013695	Hex Nut, 3/4"-10 GR 5	6
041729	Plate	2
155061	Bracket, Right	1
155067	Bracket, Left	1
F018599	Cap Screw, 1/2-13 x 5" GR 5 Hex Hd.	6
F022037	Hex Flg Nut, 1/2"-13 GR 5	6
117633	Axle Hook	2
F020458	Cap Screw, 3/4-10 x 2-1/2" GR 8 Hex Hd	2
M022621	Pivot Plate Spacer	2
F021137	Hardened Washer.	2
F001753	Wrought Washer, 3/4".	4
F023375	Hex Flg Nut, 3/4"-10 GR 8	2
130620	Pull Rod	1
130621	Pull Rod	1
F001267	Wrought Washer, 1/2".	2
F001104	Cotter Pin, 1/8 x 1"	2
126411	Bracket	2
F011954	Spring Pin, 3/8 x 1-1/2".	4
F009825	Cap Screw, 1/4-20 x 1" GR 5 Hex Hd.	4
F009535	Lock Washer, 1/4".	4
F007022	Hex Nut, 1/4"-20 GR 5	4
F020964	Collar	2
F020598	Spring	2
F014260K	Ball Handle	2
020722	Front Unit Application Drawing	

154544 MOUNTING BRACKET GROUP

PART NO	DESCRIPTION	QTY
154544	MOUNTING BRACKET GROUP	1

Parts For Rear Unit Mounting

154391	Shim, 1/8" (use as required)	4
154392	Shim, 16 ga. (use as required)	4
F006382	Cap Screw, 3/4-10 x 2-1/2" GR 5 Hex Hd	4
F018833	Cap Screw, 3/4-10 x 2-1/2" Flt Hd	2
F001354	SAE Lock Washer, 3/4"	6
F013695	Hex Nut, 3/4"-10 GR 5	6
126412	Wheel Stop Bracket, Left	1
126415	Wheel Stop Bracket, Right	1
124610	Wheel Stop Support	2
F018861	Cap Screw, 1/2-13 x 2-1/4" GR 8 Hex Hd	8
F022037	Hex Flg Nut, 1/2"-13 GR 5	8
F018650	Cap Screw, 1/2-13 x 1-1/2" GR 8 Hex Hd	4
F001075	SAE Lock Washer, 1/2"	4
F018812	Hex Nut, 1/2"-13 GR 8	4
F010812K	Bumper	2
F001007	Cap Screw, 3/8-16 x 1" GR 5 Hex Hd	4
F001025	SAE Lock Washer, 3/8"	4
F007020	Hex Nut, 3/8"-16 GR 5	4
020631	Rear Unit Application Drawing	

154550 MOUNTING BRACKET GROUP

PART NO	DESCRIPTION	QTY
154550	MOUNTING BRACKET GROUP	1

Parts For Front Unit Mounting

154393	Shim, 1/8" (use as required)	2
154394	Shim, 16 ga. (use as required)	2
F006382	Cap Screw, 3/4-10 x 2-1/2" GR 5 Hex Hd	6
F001354	SAE Lock Washer, 3/4"	6
F013695	Hex Nut, 3/4"-10 GR 5	6
154545	Axle Hook Bracket	1
154548	Axle Hook Bracket	1
F007941	Cap Screw, 5/8-11 x 5" GR 5 Hex Hd.	6
F021924	Hex Flg Nut, 5/8"-11 GR 5	6
130632	Hook Arm	2
F020458	Cap Screw, 3/4-10 x 2-1/2" GR 8 Hex Hd	2
M022621	Pivot Plate Spacer	2
F021137	Hardened Washer	2
F023375	Hex Flg Nut, 3/4"-10 GR 8	2
130457	Axle Hook	2
F015807	Cap Screw, 5/8-18 x 1-3/4" GR 5 Hex Hd	4
F020917	Hex Flg Nut, 5/8"-18	4
130620	Pull Rod	1
130621	Pull Rod	1
F001267	Wrought Washer, 1/2"	2
F001104	Cotter Pin, 1/8 x 1"	2
126411	Bracket	2
F011954	Spring Pin, 3/8 x 1-1/2"	4
F009825	Cap Screw, 1/4-20 x 1" GR 5 Hex Hd.	4
F009535	Lock Washer, 1/4"	4
F007022	Hex Nut, 1/4"-20 GR 5	4
F020964	Collar	2
F020598	Spring	2
F014260K	Ball Handle	2
020464	Front Unit Application Drawing	

154550 MOUNTING BRACKET GROUP

PART NO	DESCRIPTION	QTY
154550	MOUNTING BRACKET GROUP	1

Parts For Rear Unit Mounting

154391	Shim, 1/8" (use as required)	4
154392	Shim, 16 ga. (use as required)	4
F006382	Cap Screw, 3/4-10 x 2-1/2" GR 5 Hex Hd	4
F018833	Cap Screw, 3/4-10 x 2-1/2" Flt Hd	2
F001354	SAE Lock Washer, 3/4"	6
F013695	Hex Nut, 3/4"-10 GR 5	6
154554	Channel (frame extension, weld on)	2
F007986	Cap Screw, 3/4-10 x 3" GR 5 Hex Hd.	4
F024283	Cap Screw, 3/4-10 x 3" Hex Hd	2
126412	Wheel Stop Bracket, Left	1
126415	Wheel Stop Bracket, Right	1
124610	Wheel Stop Support	2
F018861	Cap Screw, 1/2-13 x 2-1/4" GR 8 Hex Hd	8
F022037	Hex Flg Nut, 1/2"-13 GR 5	8
124610	Cap Screw, 1/2-13 x 1-1/2" GR 8 Hex Hd	2
F001075	SAE Lock Washer, 1/2"	4
F018812	Hex Nut, 1/2"-13 GR 8	4
F010812K	Bumper	2
F001007	Cap Screw, 3/8-16 x 1" GR 5 Hex Hd.	4
F001025	SAE Lock Washer, 3/8"	4
F007020	Hex Nut, 3/8"-16 GR 5	4
020465	Rear Unit Application Drawing	

155055 MOUNTING BRACKET GROUP

PART NO	DESCRIPTION	QTY
155055	MOUNTING BRACKET GROUP	1

Parts For Front Unit Mounting

154393	Shim, 1/8" (use as required)	2
154394	Shim, 16 ga. (use as required)	2
F006382	Cap Screw, 3/4-10 x 2-1/2" GR 5 Hex Hd	6
F001354	SAE Lock Washer, 3/4"	6
F013695	Hex Nut, 3/4"-10 GR 5	6
154505	Axle Hook Bracket	1
154508	Axle Hook Bracket	1
F005454	Cap Screw, 5/8-11 x 5-1/2" GR 5 Hex Hd	6
F021924	Hex Flg Nut, 5/8"-11 GR 5	6
130458	Hook Arm	2
F020458	Cap Screw, 3/4-10 x 2-1/2" GR 8 Hex Hd	2
M022621	Pivot Plate Spacer	2
F001753	Wrought Washer, 3/4"	2
F023375	Hex Flg Nut, 3/4"-10 GR 8	2
130457	Axle Hook	2
F015807	Cap Screw, 5/8-18 x 1-3/4" GR 5 Hex Hd	4
F020917	Hex Flg Nut, 5/8"-18	4
125789	Pull Rod	2
F001267	Wrought Washer, 1/2"	2
F001104	Cotter Pin, 1/8 x 1"	2
F020964	Collar	2
126411	Bracket	2
F011954	Spring Pin, 3/8 x 1-1/2"	4
F009825	Cap Screw, 1/4-20 x 1" GR 5 Hex Hd	4
F009535	Lock Washer, 1/4"	4
F007022	Hex Nut, 1/4"-20 GR 5	4
F020598	Spring	2
F014260K	Ball Handle	2
020600	Front Unit Application Drawing	

155055 MOUNTING BRACKET GROUP

PART NO	DESCRIPTION	QTY
155055	MOUNTING BRACKET GROUP	1

Parts For Rear Unit Mounting

154391	Shim, 1/8" (use as required)	4
154392	Shim, 16 ga. (use as required)	4
F006382	Cap Screw, 3/4-10 x 2-1/2" GR 5 Hex Hd	4
F018833	Cap Screw, 3/4-10 x 2-1/2" Flt Hd	2
F001354	SAE Lock Washer, 3/4"	6
F013695	Hex Nut, 3/4"-10 GR 5	6
126412	Wheel Stop Bracket, Left	1
126415	Wheel Stop Bracket, Right	1
124610	Wheel Stop Support	2
F018861	Cap Screw, 1/2-13 x 2-1/4" GR 8 Hex Hd	8
F022037	Hex Flg Nut, 1/2"-13 GR 5	8
F018650	Cap Screw, 1/2-13 x 1-1/2" GR 8 Hex Hd	4
F001075	SAE Lock Washer, 1/2"	4
F018812	Hex Nut, 1/2"-13 GR 8	4
F010812K	Bumper	2
F001007	Cap Screw, 3/8-16 x 1" GR 5 Hex Hd	4
F001025	SAE Lock Washer, 3/8"	4
F007020	Hex Nut, 3/8"-16 GR 5	4
020601	Rear Unit Application Drawing	

155062 MOUNTING BRACKET GROUP

PART NO	DESCRIPTION	QTY
155062	MOUNTING BRACKET GROUP	1

Parts For Front Unit Mounting

154393	Shim, 1/8" (use as required)	2
154394	Shim, 16 ga. (use as required)	2
F006382	Cap Screw, 3/4-10 x 2-1/2" GR 5 Hex Hd	6
F001354	SAE Lock Washer, 3/4"	6
F013695	Hex Nut, 3/4"-10 GR 5	6
154505	Axle Hook Bracket	1
154508	Axle Hook Bracket	1
F005454	Cap Screw, 5/8-11 x 5-1/2" GR 5 Hex Hd	6
F021924	Hex Flg Nut, 5/8"-11 GR 5	6
130458	Hook Arm	2
F020458	Cap Screw, 3/4-10 x 2-1/2" GR 8 Hex Hd	2
M022621	Pivot Plate Spacer	2
F001753	Wrought Washer, 3/4"	2
F023375	Hex Flg Nut, 3/4"-10 GR 8	2
130457	Axle Hook	2
F015807	Cap Screw, 5/8-18 x 1-3/4" GR 5 Hex Hd	4
F020917	Hex Flg Nut, 5/8"-18	4
125789	Pull Rod	2
F001267	Wrought Washer, 1/2"	2
F001104	Cotter Pin, 1/8 x 1"	2
F020964	Collar	2
126411	Bracket	2
F011954	Spring Pin, 3/8 x 1-1/2"	4
F009825	Cap Screw, 1/4-20 x 1" GR 5 Hex Hd	4
F009535	Lock Washer, 1/4"	4
F007022	Hex Nut, 1/4"-20 GR 5	4
F020598	Spring	2
F014260K	Ball Handle	2
020600	Front Unit Application Drawing	

155062 MOUNTING BRACKET GROUP

PART NO	DESCRIPTION	QTY
155062	MOUNTING BRACKET GROUP	1

Parts For Rear Unit Mounting

154391	Shim, 1/8" (use as required)	4
154392	Shim, 16 ga. (use as required)	4
F006382	Cap Screw, 3/4-10 x 2-1/2" GR 5 Hex Hd	4
F018833	Cap Screw, 3/4-10 x 2-1/2" Flt Hd	2
F001354	SAE Lock Washer, 3/4"	6
F013695	Hex Nut, 3/4"-10 GR 5	6
154510	Channel (frame extension, weld on)	2
126412	Wheel Stop Bracket, Left	1
126415	Wheel Stop Bracket, Right	1
124610	Wheel Stop Support	2
F018861	Cap Screw, 1/2-13 x 2-1/4" GR 8 Hex Hd	8
F022037	Hex Flg Nut, 1/2"-13 GR 5	8
F018650	Cap Screw, 1/2-13 x 1-1/2" GR 8 Hex Hd	4
F001075	SAE Lock Washer, 1/2"	4
F018812	Hex Nut, 1/2"-13 GR 8	4
F010812K	Bumper	2
F001007	Cap Screw, 3/8-16 x 1" GR 5 Hex Hd	4
F001025	SAE Lock Washer, 3/8"	4
F007020	Hex Nut, 3/8"-16 GR 5	4
020469	Rear Unit Application Drawing	

SECTION 8 - VEHICLE APPLICATIONS
TABLE OF CONTENTS

1998 CHEVROLET / GMC 8 - 2
1999 CHEVROLET / GMC 8 - 2
2000 CHEVROLET / GMC 8 - 3
2001 CHEVROLET / GMC 8 - 3
2002 CHEVROLET / GMC 8 - 4
1998 INTERNATIONAL 8 - 5
1999 INTERNATIONAL 8 - 7
2000 INTERNATIONAL 8 - 9
2001 INTERNATIONAL 8 - 11
2002 INTERNATIONAL 8 - 13
1999 STERLING 8 - 15
2000 STERLING 8 - 16
2001 STERLING 8 - 17
2002 STERLING 8 - 18
1998 VOLVO WHITE GMC 8 - 19
1999 VOLVO WHITE GMC 8 - 19
2000 VOLVO WHITE GMC 8 - 20
2001 VOLVO WHITE GMC 8 - 20
2002 VOLVO WHITE GMC 8 - 21

1998 CHEV/GMC C7H042 12,000 GAWR FRONT AXLE	1999 CHEV/GMC C7H042 12,000 GAWR FRONT AXLE
--	--

REQUIRED GROUPS

Front Guide Wheel Unit	140142	140142
Rear Guide Wheel Unit	140177	140177
Mounting Brackets	154544	154544
Steering Lock	155079	155079
Application Drawing - Front	020722	020722
Application Drawing - Rear	020631	020631

ACCESSORY GROUP OPTIONS

* Rail Sweeps - Front or Rear.	108480	108480
Rear Unit Brakes	120977	120977
** Air / Hydraulic Brake System	125475	125475
Truck Brake Connection.	154057	154057
Rear Brake Connection	121278	121278
** Brake Control	127084	127084
Hydraulic Power Pack - Full	137926	137926
Hydraulic Power Pack - Abbreviated	137927	137927
Sight Rod Kit And Extension	164574	164574

* Recommended Safety Option

** Used On Trucks Without Air Brakes

2000 CHEV/GMC C7H042 12,000 GAWR FRONT AXLE	2001 CHEV/GMC C7H042 12,000 GAWR FRONT AXLE
--	--

REQUIRED GROUPS

Front Guide Wheel Unit	140142	140142
Rear Guide Wheel Unit	140177	140177
Mounting Brackets	154544	154544
Steering Lock	155079	155079
Application Drawing - Front	020722	020722
Application Drawing - Rear	020631	020631

ACCESSORY GROUP OPTIONS

* Rail Sweeps - Front or Rear.	108480	108480
Rear Unit Brakes	120977	120977
** Air / Hydraulic Brake System	125475	125475
Truck Brake Connection.	154057	154057
Rear Brake Connection	121278	121278
** Brake Control	127084	127084
Hydraulic Power Pack - Full	137926	137926
Hydraulic Power Pack - Abbreviated	137927	137927
Sight Rod Kit And Extension	164574	164574

* Recommended Safety Option

** Used On Trucks Without Air Brakes

2002 CHEV/GMC
C7H042
12,000 GAWR
FRONT AXLE

REQUIRED GROUPS

Front Guide Wheel Unit	140142
Rear Guide Wheel Unit	140177
Mounting Brackets	154544
Steering Lock	155079
Application Drawing - Front	020722
Application Drawing - Rear	020631

ACCESSORY GROUP OPTIONS

* Rail Sweeps - Front or Rear.	108480
Rear Unit Brakes	120977
** Air / Hydraulic Brake System	125475
Truck Brake Connection.	154057
Rear Brake Connection	121278
** Brake Control	127084
Hydraulic Power Pack - Full	137926
Hydraulic Power Pack - Abbreviated	137927
Sight Rod Kit And Extension	164574

* Recommended Safety Option

** Used On Trucks Without Air Brakes

1998 INTERNATIONAL 4900 10,860 GAWR FRONT AXLE TANDEM REAR AXLE WITHOUT FRONT FRAME EXTENSION	1998 INTERNATIONAL 4900 10,860 GAWR FRONT AXLE TANDEM REAR AXLE WITH FRONT FRAME EXTENSION
---	--

REQUIRED GROUPS

Front Guide Wheel Unit	140142	140142
Rear Guide Wheel Unit	140177	140177
Mounting Brackets	154540	155062
Steering Lock	186205	186205
Application Drawing - Front	020468	020600
Application Drawing - Rear	020469	020469

ACCESSORY GROUP OPTIONS

* Rail Sweeps - Front or Rear	108480	108480
Rear Unit Brakes	120977	120977
** Air / Hydraulic Brake System	125475	125475
Truck Brake Connection	154513	154513
Rear Brake Connection	121278	121278
** Brake Control	127084	127084
Hydraulic Power Pack - Full	137926	137926
Hydraulic Power Pack - Abbreviated	137927	137927
Sight Rod Kit And Extension	164574	164574

* Recommended Safety Option

** Used On Trucks Without Air Brakes

1998 INTERNATIONAL
4900
10,860 GAWR
FRONT AXLE
SINGLE REAR AXLE
WITHOUT FRONT
FRAME EXTENSION

REQUIRED GROUPS

Front Guide Wheel Unit	140142
Rear Guide Wheel Unit	140177
Mounting Brackets	155055
Steering Lock	186205
Application Drawing - Front	020600
Application Drawing - Rear	020601

ACCESSORY GROUP OPTIONS

* Rail Sweeps - Front or Rear.	108480
Rear Unit Brakes	120977
** Air / Hydraulic Brake System	125475
Truck Brake Connection.	154513
Rear Brake Connection	121278
** Brake Control	127084
Hydraulic Power Pack - Full	137926
Hydraulic Power Pack - Abbreviated	137927
Sight Rod Kit And Extension	164574

* Recommended Safety Option

** Used On Trucks Without Air Brakes

1999 INTERNATIONAL 4900 10,860 GAWR FRONT AXLE TANDEM REAR AXLE WITHOUT FRONT FRAME EXTENSION	1999 INTERNATIONAL 4900 10,860 GAWR FRONT AXLE TANDEM REAR AXLE WITH FRONT FRAME EXTENSION
---	--

REQUIRED GROUPS

Front Guide Wheel Unit	140142	140142
Rear Guide Wheel Unit	140177	140177
Mounting Brackets	154540	155062
Steering Lock	186205	186205
Application Drawing - Front	020468	020600
Application Drawing - Rear	020469	020469

ACCESSORY GROUP OPTIONS

* Rail Sweeps - Front or Rear	108480	108480
Rear Unit Brakes	120977	120977
** Air / Hydraulic Brake System	125475	125475
Truck Brake Connection	154513	154513
Rear Brake Connection	121278	121278
** Brake Control	127084	127084
Hydraulic Power Pack - Full	137926	137926
Hydraulic Power Pack - Abbreviated	137927	137927
Sight Rod Kit And Extension	164574	164574

* Recommended Safety Option

** Used On Trucks Without Air Brakes

1999 INTERNATIONAL
4900
10,860 GAWR
FRONT AXLE
SINGLE REAR AXLE
WITHOUT FRONT
FRAME EXTENSION

REQUIRED GROUPS

Front Guide Wheel Unit	140142
Rear Guide Wheel Unit	140177
Mounting Brackets	155055
Steering Lock	186205
Application Drawing - Front	020600
Application Drawing - Rear	020601

ACCESSORY GROUP OPTIONS

* Rail Sweeps - Front or Rear.	108480
Rear Unit Brakes	120977
** Air / Hydraulic Brake System	125475
Truck Brake Connection.	154513
Rear Brake Connection	121278
** Brake Control	127084
Hydraulic Power Pack - Full	137926
Hydraulic Power Pack - Abbreviated	137927
Sight Rod Kit And Extension	164574

* Recommended Safety Option

** Used On Trucks Without Air Brakes

2000 INTERNATIONAL 4900 10,860 GAWR FRONT AXLE TANDEM REAR AXLE WITHOUT FRONT FRAME EXTENSION	2000 INTERNATIONAL 4900 10,860 GAWR FRONT AXLE TANDEM REAR AXLE WITH FRONT FRAME EXTENSION
---	--

REQUIRED GROUPS

Front Guide Wheel Unit	140142	140142
Rear Guide Wheel Unit	140177	140177
Mounting Brackets	154540	155062
Steering Lock	186205	186205
Application Drawing - Front	020468	020600
Application Drawing - Rear	020469	020469

ACCESSORY GROUP OPTIONS

* Rail Sweeps - Front or Rear	108480	108480
Rear Unit Brakes	120977	120977
** Air / Hydraulic Brake System	125475	125475
Truck Brake Connection	154513	154513
Rear Brake Connection	121278	121278
** Brake Control	127084	127084
Hydraulic Power Pack - Full	137926	137926
Hydraulic Power Pack - Abbreviated	137927	137927
Sight Rod Kit And Extension	164574	164574

* Recommended Safety Option

** Used On Trucks Without Air Brakes

2000 INTERNATIONAL
4900
10,860 GAWR
FRONT AXLE
SINGLE REAR AXLE
WITHOUT FRONT
FRAME EXTENSION

REQUIRED GROUPS

Front Guide Wheel Unit	140142
Rear Guide Wheel Unit	140177
Mounting Brackets	155055
Steering Lock	186205
Application Drawing - Front	020600
Application Drawing - Rear	020601

ACCESSORY GROUP OPTIONS

* Rail Sweeps - Front or Rear.	108480
Rear Unit Brakes	120977
** Air / Hydraulic Brake System	125475
Truck Brake Connection.	154513
Rear Brake Connection	121278
** Brake Control	127084
Hydraulic Power Pack - Full	137926
Hydraulic Power Pack - Abbreviated	137927
Sight Rod Kit And Extension	164574

* Recommended Safety Option

** Used On Trucks Without Air Brakes

2001 INTERNATIONAL 4900 10,860 GAWR FRONT AXLE TANDEM REAR AXLE WITHOUT FRONT FRAME EXTENSION	2001 INTERNATIONAL 4900 10,860 GAWR FRONT AXLE TANDEM REAR AXLE WITH FRONT FRAME EXTENSION
---	--

REQUIRED GROUPS

Front Guide Wheel Unit	140142	140142
Rear Guide Wheel Unit	140177	140177
Mounting Brackets	154540	155062
Steering Lock	186205	186205
Application Drawing - Front	020468	020600
Application Drawing - Rear	020469	020469

ACCESSORY GROUP OPTIONS

* Rail Sweeps - Front or Rear	108480	108480
Rear Unit Brakes	120977	120977
** Air / Hydraulic Brake System	125475	125475
Truck Brake Connection	154513	154513
Rear Brake Connection	121278	121278
** Brake Control	127084	127084
Hydraulic Power Pack - Full	137926	137926
Hydraulic Power Pack - Abbreviated	137927	137927
Sight Rod Kit And Extension	164574	164574

* Recommended Safety Option

** Used On Trucks Without Air Brakes

2001 INTERNATIONAL
4900
10,860 GAWR
FRONT AXLE
SINGLE REAR AXLE
WITHOUT FRONT
FRAME EXTENSION

REQUIRED GROUPS

Front Guide Wheel Unit	140142
Rear Guide Wheel Unit	140177
Mounting Brackets	155055
Steering Lock	186205
Application Drawing - Front	020600
Application Drawing - Rear	020601

ACCESSORY GROUP OPTIONS

* Rail Sweeps - Front or Rear.	108480
Rear Unit Brakes	120977
** Air / Hydraulic Brake System	125475
Truck Brake Connection.	154513
Rear Brake Connection	121278
** Brake Control	127084
Hydraulic Power Pack - Full	137926
Hydraulic Power Pack - Abbreviated	137927
Sight Rod Kit And Extension	164574

* Recommended Safety Option

** Used On Trucks Without Air Brakes

2002 INTERNATIONAL 4900 10,860 GAWR FRONT AXLE TANDEM REAR AXLE WITHOUT FRONT FRAME EXTENSION	2002 INTERNATIONAL 4900 10,860 GAWR FRONT AXLE TANDEM REAR AXLE WITH FRONT FRAME EXTENSION
---	--

REQUIRED GROUPS

Front Guide Wheel Unit	140142	140142
Rear Guide Wheel Unit	140177	140177
Mounting Brackets	154540	155062
Steering Lock	186205	186205
Application Drawing - Front	020468	020600
Application Drawing - Rear	020469	020469

ACCESSORY GROUP OPTIONS

* Rail Sweeps - Front or Rear	108480	108480
Rear Unit Brakes	120977	120977
** Air / Hydraulic Brake System	125475	125475
Truck Brake Connection	154513	154513
Rear Brake Connection	121278	121278
** Brake Control	127084	127084
Hydraulic Power Pack - Full	137926	137926
Hydraulic Power Pack - Abbreviated	137927	137927
Sight Rod Kit And Extension	164574	164574

* Recommended Safety Option

** Used On Trucks Without Air Brakes

2002 INTERNATIONAL
4900
10,860 GAWR
FRONT AXLE
SINGLE REAR AXLE
WITHOUT FRONT
FRAME EXTENSION

REQUIRED GROUPS

Front Guide Wheel Unit	140142
Rear Guide Wheel Unit	140177
Mounting Brackets	155055
Steering Lock	186205
Application Drawing - Front	020600
Application Drawing - Rear	020601

ACCESSORY GROUP OPTIONS

* Rail Sweeps - Front or Rear.	108480
Rear Unit Brakes	120977
** Air / Hydraulic Brake System	125475
Truck Brake Connection.	154513
Rear Brake Connection	121278
** Brake Control	127084
Hydraulic Power Pack - Full	137926
Hydraulic Power Pack - Abbreviated	137927
Sight Rod Kit And Extension	164574

* Recommended Safety Option

** Used On Trucks Without Air Brakes

1999 STERLING LT-8511 16,000 GAWR FRONT AXLE	1999 STERLING LT-9511 12,000 GAWR FRONT AXLE
---	---

REQUIRED GROUPS

Front Guide Wheel Unit	140142	140142
Rear Guide Wheel Unit	140177	140177
Mounting Brackets	154389	154550
Steering Lock	154390	154390
Wheel Modification	154064	_____
Application Drawing - Front	020436	020464
Application Drawing - Rear	020437	020465

ACCESSORY GROUP OPTIONS

* Rail Sweeps - Front or Rear	108480	108480
Rear Unit Brakes	120977	120977
** Air / Hydraulic Brake System	125475	125475
Truck Brake Connection	154388	154388
Rear Brake Connection	121278	121278
** Brake Control	127084	127084
Hydraulic Power Pack - Full	137926	137926
Hydraulic Power Pack - Abbreviated	137927	137927
Sight Rod Kit And Extension	164574	164574

* Recommended Safety Option

** Used On Trucks Without Air Brakes

2000 STERLING LT-8511 16,000 GAWR FRONT AXLE	2000 STERLING LT-9511 12,000 GAWR FRONT AXLE
---	---

REQUIRED GROUPS

Front Guide Wheel Unit	140142	140142
Rear Guide Wheel Unit	140177	140177
Mounting Brackets	154389	154550
Steering Lock	154390	154390
Wheel Modification	154064	_____
Application Drawing - Front	020436	020464
Application Drawing - Rear	020437	020465

ACCESSORY GROUP OPTIONS

* Rail Sweeps - Front or Rear	108480	108480
Rear Unit Brakes	120977	120977
** Air / Hydraulic Brake System	125475	125475
Truck Brake Connection	154388	154388
Rear Brake Connection	121278	121278
** Brake Control	127084	127084
Hydraulic Power Pack - Full	137926	137926
Hydraulic Power Pack - Abbreviated	137927	137927
Sight Rod Kit And Extension	164574	164574

* Recommended Safety Option

** Used On Trucks Without Air Brakes

2001 STERLING LT-8511 16,000 GAWR FRONT AXLE	2001 STERLING LT-9511 12,000 GAWR FRONT AXLE
---	---

REQUIRED GROUPS

Front Guide Wheel Unit	140142	140142
Rear Guide Wheel Unit	140177	140177
Mounting Brackets	154389	154550
Steering Lock	154390	154390
Wheel Modification	154064	_____
Application Drawing - Front	020436	020464
Application Drawing - Rear	020437	020465

ACCESSORY GROUP OPTIONS

* Rail Sweeps - Front or Rear	108480	108480
Rear Unit Brakes	120977	120977
** Air / Hydraulic Brake System	125475	125475
Truck Brake Connection	154388	154388
Rear Brake Connection	121278	121278
** Brake Control	127084	127084
Hydraulic Power Pack - Full	137926	137926
Hydraulic Power Pack - Abbreviated	137927	137927
Sight Rod Kit And Extension	164574	164574

* Recommended Safety Option

** Used On Trucks Without Air Brakes

2002 STERLING LT-8511 16,000 GAWR FRONT AXLE	2002 STERLING LT-9511 12,000 GAWR FRONT AXLE
---	---

REQUIRED GROUPS

Front Guide Wheel Unit	140142	140142
Rear Guide Wheel Unit	140177	140177
Mounting Brackets	154389	154550
Steering Lock	154390	154390
Wheel Modification	154064	_____
Application Drawing - Front	020436	020464
Application Drawing - Rear	020437	020465

ACCESSORY GROUP OPTIONS

* Rail Sweeps - Front or Rear	108480	108480
Rear Unit Brakes	120977	120977
** Air / Hydraulic Brake System	125475	125475
Truck Brake Connection	154388	154388
Rear Brake Connection	121278	121278
** Brake Control	127084	127084
Hydraulic Power Pack - Full	137926	137926
Hydraulic Power Pack - Abbreviated	137927	137927
Sight Rod Kit And Extension	164574	164574

* Recommended Safety Option

** Used On Trucks Without Air Brakes

1998 VOLVO WHITE	1999 VOLVO WHITE
GMC WG64	GMC WG64
16,000 GAWR	16,000 GAWR
FRONT AXLE	FRONT AXLE

REQUIRED GROUPS

Front Guide Wheel Unit	140142	140142
Rear Guide Wheel Unit	140177	140177
Mounting Brackets	154062	154062
Steering Lock	162315	162315
Wheel Modification	154064	154064
Application Drawing - Front	020466	020466
Application Drawing - Rear	020467	020467

ACCESSORY GROUP OPTIONS

* Rail Sweeps - Front or Rear	108480	108480
Rear Unit Brakes	120977	120977
** Air / Hydraulic Brake System	125475	125475
Truck Brake Connection	154057	154057
Rear Brake Connection	121278	121278
** Brake Control	127084	127084
Hydraulic Power Pack - Full	137926	137926
Hydraulic Power Pack - Abbreviated	137927	137927
Sight Rod Kit And Extension	164574	164574

* Recommended Safety Option

** Used On Trucks Without Air Brakes

2000 VOLVO WHITE	2001 VOLVO WHITE
GMC WG64	GMC WG64
16,000 GAWR	16,000 GAWR
FRONT AXLE	FRONT AXLE

REQUIRED GROUPS

Front Guide Wheel Unit	140142	140142
Rear Guide Wheel Unit	140177	140177
Mounting Brackets	154062	154062
Steering Lock	162315	162315
Wheel Modification	154064	154064
Application Drawing - Front	020466	020466
Application Drawing - Rear	020467	020467

ACCESSORY GROUP OPTIONS

* Rail Sweeps - Front or Rear	108480	108480
Rear Unit Brakes	120977	120977
** Air / Hydraulic Brake System	125475	125475
Truck Brake Connection	154057	154057
Rear Brake Connection	121278	121278
** Brake Control	127084	127084
Hydraulic Power Pack - Full	137926	137926
Hydraulic Power Pack - Abbreviated	137927	137927
Sight Rod Kit And Extension	164574	164574

* Recommended Safety Option

** Used On Trucks Without Air Brakes

2002 VOLVO WHITE
GMC WG64
16,000 GAWR
FRONT AXLE

REQUIRED GROUPS

Front Guide Wheel Unit	140142
Rear Guide Wheel Unit	140177
Mounting Brackets	154062
Steering Lock	162315
Wheel Modification	154064
Application Drawing - Front	020466
Application Drawing - Rear	020467

ACCESSORY GROUP OPTIONS

* Rail Sweeps - Front or Rear	108480
Rear Unit Brakes	120977
** Air / Hydraulic Brake System	125475
Truck Brake Connection	154057
Rear Brake Connection	121278
** Brake Control	127084
Hydraulic Power Pack - Full	137926
Hydraulic Power Pack - Abbreviated	137927
Sight Rod Kit And Extension	164574

* Recommended Safety Option

** Used On Trucks Without Air Brakes

Limited Warranty

HARSCO TRACK TECHNOLOGIES products are designed to give high quality service and are manufactured from high grade material, by competent workmen under careful supervision. Harsco Track Technologies, Harsco Corporation warrants products of its manufacture to be free of defects in material and workmanship, under normal use and service for a period of six (6) months from date of delivery to the original user. The obligation of Harsco Track Technologies, Harsco Corporation under this warranty is limited to repairing or replacing at its factories, or other location designated by it, any part or parts thereof which are returned within 30 days of the date when failure occurs or defect is noted, with transportation charges prepaid, and which upon examination appears to the satisfaction of Harsco Track Technologies, Harsco Corporation to have been defective. Such free repair or replacement does not include transportation charges, or the cost of installing the new part or any other expense incident thereto. Harsco Track Technologies, Harsco Corporation will not be liable for other loss, damage, or expense directly or indirectly arising from the use of its products, nor will Harsco Track Technologies, Harsco Corporation be liable for special, incidental or consequential damages.

Ordinary wear and tear, and damage from abuse, misuse, neglect or alteration are not covered by this warranty. Harsco Track Technologies, Harsco Corporation assumes no liability for expenses incurred or repairs made outside its factories except by written consent. This warranty is null and void if instructions and operating procedures are not followed.

Equipment or parts not manufactured by this company, but which are furnished in connection with HARSCO TRACK TECHNOLOGIES products, are covered directly by the warranty of the manufacturer supplying them. However, Harsco Track Technologies, Harsco Corporation will assist in obtaining adjustment on such equipment or parts when necessary.

THIS WARRANTY IS IN LIEU OF ALL OTHER WARRANTIES EXPRESSED OR IMPLIED INCLUDING ANY IMPLIED WARRANTIES OF MERCHANTABILITY OR FITNESS FOR A PARTICULAR PURPOSE AND OF ANY OTHER OBLIGATION OR LIABILITY OF HARSCO TRACK TECHNOLOGIES, HARSCO CORPORATION.

Product Improvement Liability Disclaimer

HARSCO TRACK TECHNOLOGIES, HARSCO CORPORATION RESERVES THE RIGHT TO MAKE ANY CHANGES IN OR IMPROVEMENTS ON ITS PRODUCTS WITHOUT INCURRING ANY LIABILITY OR OBLIGATION WHATEVER AND WITHOUT BEING REQUIRED TO MAKE ANY CORRESPONDING CHANGES OR IMPROVEMENTS IN PRODUCTS PREVIOUSLY MANUFACTURED OR SOLD.

Hazardous Material Disclaimer

THE PARTS/ASSEMBLIES THAT ARE USED IN THIS PRODUCT ARE CLASSIFIED AS "ARTICLES" ACCORDING TO 29 CFR 1910.1200 (C). THEY ARE FORMED TO A SPECIFIC SHAPE OR DESIGN DURING MANUFACTURE, HAVE END USE FUNCTION DEPENDENT UPON THEIR SHAPE OR DESIGN, AND DO NOT RELEASE ANY HAZARDOUS CHEMICAL UNDER NORMAL CONDITIONS OF USE. ACCORDINGLY, WE ARE NOT REQUIRED TO SUPPLY MATERIAL SAFETY DATA SHEETS (MSDS) OR TO LABEL SHIPPING CONTAINERS FOR "ARTICLES". HOWEVER, LUBRICANTS, LIQUIDS, GASEOUS CHEMICALS AND SOLIDS USED IN OPERATION OR MAINTENANCE OF THE PRODUCT MAY REQUIRE THAT USER'S TAKE OCCUPATIONAL PROTECTIVE MEASURES. MSDS SHEETS FOR SUCH MATERIALS WILL BE SUPPLIED TO YOUR PURCHASING MANAGER/SAFETY DIRECTOR TO BE USED IN YOUR EMPLOYEE SAFETY TRAINING EDUCATION AND ENVIRONMENTAL HEALTH TRAINING.

HTT

Harsco Track Technologies

Harsco

HARSCO TRACK TECHNOLOGIES
HARSCO CORPORATION
415 North Main Street
Fairmont, Minnesota, 56031-1837 U.S.A.

BULLETIN 1143A

Printed In U.S.A.

ISSUED 7 - 2002

© 2002 HARSCO TRACK TECHNOLOGIES, HARSCO CORPORATION